

# Residential Product Guide

---





## A. O. Smith Water Heaters

It's no surprise that we've built a global reputation for water heating innovation. What might come as a surprise is the fact that we view this accomplishment as a mere beginning – an indication of even greater things to come.

We employ over 10,000 people worldwide committed to research, innovation and customer service excellence. Our engineering facilities, labs, robust testing procedures, and protective coatings and electronics division deliver the highest quality and advanced designs for water heating.

# Table of Contents

## RESIDENTIAL TANK-TYPE PRODUCTS

<b>Electric Water Heaters</b> .....	<b>4</b>
ProLine® & ProLine® Master .....	4
ProLine® Master Connected.....	6
Space Saver®.....	8
ProLine® XE Heat Pump.....	10
<b>Gas Water Heaters</b> .....	<b>12</b>
ProLine® & ProLine® Master Atmospheric Vent.....	12
ProLine® XE Atmospheric Vent.....	14
ProLine® XE Power Vent.....	16
ProLine® XE Power Direct Vent.....	18
ProLine® Direct Vent .....	20
<b>High-efficiency Gas Water Heaters</b> .....	<b>22</b>
Vertex® Power Vent .....	22
Vertex® Power Direct Vent.....	24
Vertex® HV .....	26
Polaris™ .....	28

## RESIDENTIAL TANKLESS PRODUCTS

Powered by Takagi .....	30
<b>Electric Tankless Products</b> .....	<b>31</b>
Point of Use Tankless.....	31
<b>Gas Tankless Products</b> .....	<b>32</b>
Adapt™ Tankless.....	32
Condensing Tankless .....	36

## APPENDICES

Ohm's Law .....	40
Reference Guide for Water Heating.....	40

## ProLine® & ProLine® Master Electric

### ENERGY SAVINGS

- Meets and exceeds NRCan energy efficiency standards
- Styropour™ base for added energy efficiency

### DESIGNED FOR PERFORMANCE

- ProLine® and ProLine® Master models are residential water heaters with commercial-grade quality
- Factory-installed plastic-lined heat trap nipples
- Blue Diamond® glass coating protects steel tank from corrosion and maximizes tank life
- Thermostatically controlled, long life elements
- Brass drain valve
- CFC-free foam insulation

### SERVICEABILITY

- Conveniently located T&P and drain valve for ease of installation and serviceability
- CoreGard™ magnesium anode with a stainless steel core protects the tank against corrosion

### DynaClean™ DIFFUSER DIP TUBE

- Helps reduce lime and sediment buildup, maximizes hot water output and is made from long-lasting PEX cross-linked polymer

### WARRANTY

- 6 year limited tank and parts warranty on ProLine® models
- 8 year limited tank and parts warranty on ProLine® Master models
- 2 and 4 year tank warranty extension kits are available for 6 year models

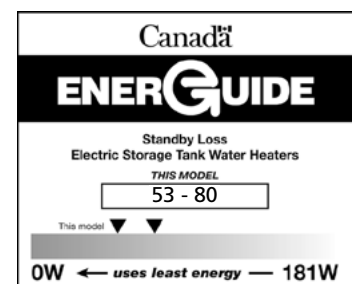

# Commercial-Grade Residential Water Heaters

## SPECIFICATIONS

MODEL	SERIES	CAPACITY			ELEMENTS (UPPER AND LOWER)		STANDBY LOSS WATTS	ENERGY FACTOR	FIRST HOUR RATING USG (L)	HEIGHT TO TOP OF TANK A IN (CM)	DIAMETER B IN (CM)	SHIPPING WEIGHT LB (KG)	WARRANTY TANK/PARTS YEARS	BC/ON/QC COMPLIANT
		IG	USG	LITRES	WATTS	VOLTS								
<b>TOP ENTRY</b>														
EPSX 50	250	40	50	182	3000	208	53	0.92	50 (188)	48 3/4 (124)	22 (56)	125 (57)	6/6	√
EPSX 50	250	40	50	182	3000*	240	53	0.92	50 (188)	48 3/4 (124)	22 (56)	125 (57)	6/6	√
EPSX 50	250	40	50	182	3800**	240	53	0.92	53 (202)	48 3/4 (124)	22 (56)	125 (57)	6/6	√
EPSX 50	250	40	50	182	4500	208	53	0.92	57 (214)	48 3/4 (124)	22 (56)	125 (57)	6/6	√
EPSX 50	250	40	50	182	4500***	240	53	0.92	57 (214)	48 3/4 (124)	22 (56)	125 (57)	6/6	√
EPSX 50	250	40	50	182	5500	208	53	0.92	61 (231)	48 3/4 (124)	22 (56)	125 (57)	6/6	√
EPSX 50	250	40	50	182	6000****	240	53	0.92	63 (240)	48 3/4 (124)	22 (56)	125 (57)	6/6	√
ECT 66	275	50	66	250	3800**	240	79	0.88	69 (261)	60 1/4 (153)	22 (56)	146 (66)	6/6	
ECT 66	275	50	66	250	4500	208	79	0.88	72 (273)	60 1/4 (153)	22 (56)	146 (66)	6/6	
ECT 66	275	50	66	250	4500***	240	79	0.88	72 (273)	60 1/4 (153)	22 (56)	146 (66)	6/6	
ECT 80	250	60	80	287	3000	208	78	0.90	74 (279)	60 1/2 (154)	24 (61)	170 (77)	6/6	√
ECT 80	250	60	80	287	3000*	240	78	0.90	74 (279)	60 1/2 (154)	24 (61)	170 (77)	6/6	√
ECT 80	250	60	80	287	3800**	240	78	0.90	77 (293)	60 1/2 (154)	24 (61)	170 (77)	6/6	√
ECT 80	250	60	80	287	4500	208	78	0.90	81 (305)	60 1/2 (154)	24 (61)	170 (77)	6/6	√
ECT 80	250	60	80	287	4500***	240	78	0.90	81 (305)	60 1/2 (154)	24 (61)	170 (77)	6/6	√
ECT 80	250	60	80	287	5500	208	78	0.90	85 (322)	60 1/2 (154)	24 (61)	170 (77)	6/6	√
ECT 80	250	60	80	287	6000****	240	78	0.90	87 (331)	60 1/2 (154)	24 (61)	170 (77)	6/6	√
<b>TOP ENTRY</b>														
HPSX 50	250	40	50	182	3000*	240	53	0.92	50 (188)	48 3/4 (124)	22 (56)	125 (57)	8/8	√
HPSX 50	250	40	50	182	3800**	240	53	0.92	53 (202)	48 3/4 (124)	22 (56)	125 (57)	8/8	√
HCT 80	250	60	80	287	4500***	240	78	0.90	81 (305)	60 1/2 (154)	24 (61)	170 (77)	8/8	√
<b>BOTTOM ENTRY</b>														
EJSH 50	250	40	50	182	3000	208	65	0.91	50 (188)	48 (122)	22 (56)	122 (55)	6/6	√
EJSH 50	250	40	50	182	3000*	240	65	0.91	50 (188)	48 (122)	22 (56)	122 (55)	6/6	√
EJSH 50	250	40	50	182	4500	208	65	0.91	57 (214)	48 (122)	22 (56)	122 (55)	6/6	√
EJSH 50	250	40	50	182	4500**	240	65	0.91	57 (214)	48 (122)	22 (56)	122 (55)	6/6	√
EJTH 80	250	60	80	287	3000	208	80	0.90	74 (279)	60 1/2 (154)	24 (61)	170 (77)	6/6	√
EJTH 80	250	60	80	287	3000*	240	80	0.90	74 (279)	60 1/2 (154)	24 (61)	170 (77)	6/6	√
EJTH 80	250	60	80	287	4500	208	80	0.90	81 (305)	60 1/2 (154)	24 (61)	170 (77)	6/6	√
EJTH 80	250	60	80	287	4500**	240	80	0.90	81 (305)	60 1/2 (154)	24 (61)	170 (77)	6/6	√

All models comply with national energy efficiency regulations.

\*Model is dual-rated. At 208V wattage is 2253.

\*\*Model is dual-rated. At 208V wattage is 2854.

\*\*\*Model is dual-rated. At 208V wattage is 3380.

\*\*\*\*Model is dual-rated. At 208V wattage is 4507.

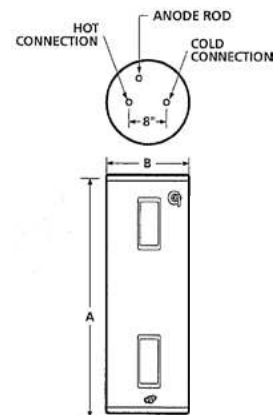
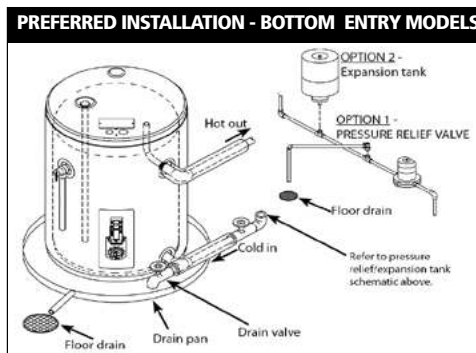
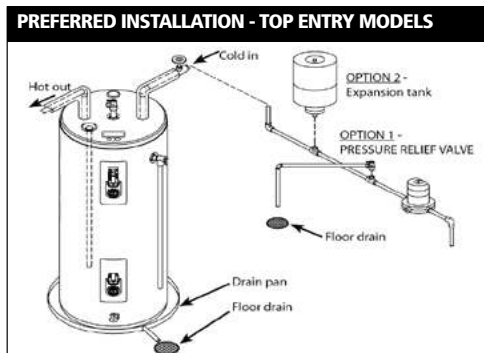

**For Technical Information call 888-599-2837. A. O. Smith Enterprises Ltd. reserves the right to make product changes or improvements without prior notice.**

## PROLINE® MASTER SMART ELECTRIC WATER HEATERS

Get smarter hot water from A. O. Smith. Our ProLine® Master Smart Electric water heaters are designed with iCOMM™ Wi-Fi technology and leak detection to provide homeowners with greater control and added peace of mind.

### ELECTRONIC CONTROLS WITH WIFI CONNECTIVITY

- Standard and vacation operating modes
- Seven-segment display
- Diagnostic feedback
- Element dry-fire protection

### REMOTE CONTROL THROUGH THE A. O. SMITH APP

- Change water temperature and operating mode remotely
- View energy usage and hot water availability
- Schedule hot water demand for optimized performance

### LEAK DETECTION SENSOR

- Sounds an audible alarm when water is detected

### ENHANCED HEATING ELEMENTS

- Dual elements for the fastest recovery and reliable operation

### SELF CLEANING DIP TUBE

- Helps reduce lime and sediment buildup and maximizes hot water output.
- Made from long-lasting PEX cross-linked polymer

### COREGARD™ ANODE ROD

- A stainless steel core extends the life of the anode rod allowing superior tank protection far longer than standard anode rods

### BLUE DIAMOND® GLASS COATING

- Provides superior corrosion resistance compared to industry standard glass lining

### ENHANCED-FLOW BRASS DRAIN VALVE

- Solid brass, tamper resistant, enhanced-flow, ball type, drain valve
- Uses a standard female hose fitting that allows for fast and easy draining during maintenance
- Designed for easy operation, this valve includes an integral screwdriver slot that features a ¼ turn (open/close) radius, which not only permits full straight-through water flow but also a quick and positive shut off

### OPTIONAL SHUT-OFF VALVE

- Valve automatically shuts off incoming cold water when leak is detected (kit #100345338)

### CODE COMPLIANCE

- Meets NRCAN standby loss requirements

### CSA CERTIFIED AND ASME RATED T&P RELIEF VALVE

### DESIGN-LISTED BY UNDERWRITERS LABORATORIES

- Certified at 300 psi test pressure and 150 psi working pressure
- Listed according to UL 174 standards governing storage tank-type electric water heaters

### 8-YEAR LIMITED TANK AND PARTS WARRANTY

- For complete information, consult written warranty or go to [hotwatercanada.ca](http://hotwatercanada.ca)

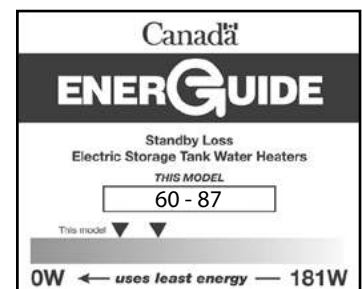

# Commercial-Grade Residential Water Heaters

## SPECIFICATIONS

MODEL	SERIES	CAPACITY			INPUT		STANDBY LOSS WATTS	FIRST HOUR RATING USG (L)	HEIGHT TO TOP OF TANK A IN (CM)	DIAMETER B IN (CM)	SHIPPING WEIGHT LB (KG)	WARRANTY TANK/PARTS YEARS	BC/ON/QC COMPLIANT
		IG	USG	LITRES	240V	208V							
<b>TOP ENTRY</b>													
HEHC-50	100	40	50	182	3,000W	2,253W	60	50 (188)	49 1/4 (125)	23 (59)	117 (53)	8/8	√
HEHC-50	100	40	50	182	3,800W	3,000W	60	53 (202)	49 1/4 (125)	23 (59)	117 (53)	8/8	√
HEHC-80	100	60	80	287	4,500W	3,500W	87	81 (305)	60 1/2 (154)	24 (61)	174 (79)	8/8	√
HEHC-80	100	60	80	287	5,500W	4,000W	87	85 (322)	60 1/2 (154)	24 (61)	174 (79)	8/8	√

3/4" water connections on 8" center.

Equipped as dual element only, no single element configurations available.

Dimensions and specifications subject to change without notice in accordance with our policy of continuous product improvement.

## CONTROL PANEL



## iCOMM™ SMART CONNECTIVITY

Download the free A. O. Smith app to get started.



Apple logo and Apple App Store Logo are trademarks of Apple Inc. Google Play and the Google Play logo are trademarks of Google LLC.

## PREFERRED INSTALLATION - TOP ENTRY MODELS

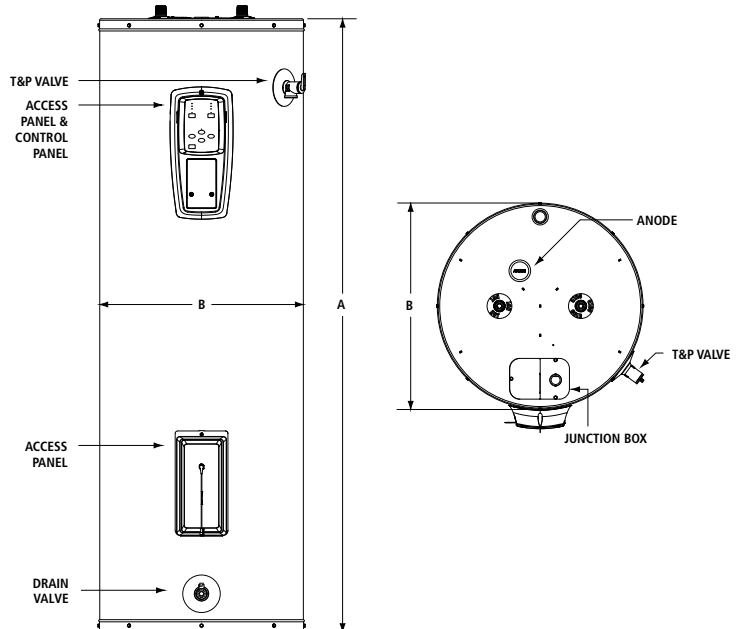
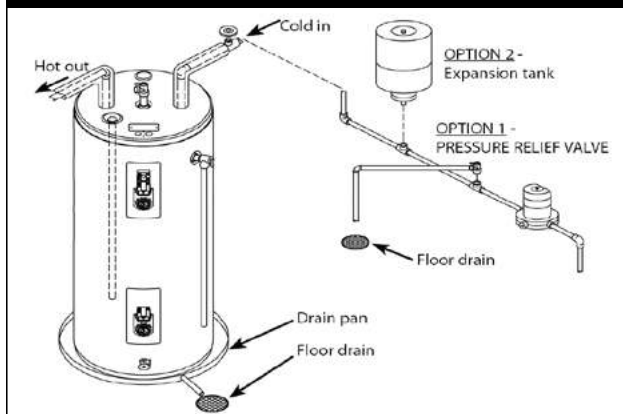

For Technical Information, call 888-599-2837. A. O. Smith Enterprises Ltd. reserves the right to make product changes or improvements without prior notice.



# Residential Electric Water Heaters

Featuring a variety of models designed for installations in cottages, offices, mobile homes or other applications where space is limited, the Space Saver® line of residential electric water heaters provides optimum reliability, performance and energy efficiency.

## DESIGNED FOR PERFORMANCE

- Exclusive TankSaver® design
- Glass-lined tanks for longer life
- Meets latest energy efficiency standards
- Factory-installed plastic-lined nipples
- Styropour™ base for added energy efficiency
- Thermostatically controlled long life elements
- CFC-free foam insulation
- Personnel protector covers elements and controls

## EASY TO INSTALL AND REPAIR

- Conveniently located T&P and drain valve
- Removable anodes

## WARRANTY

- 6 year limited tank warranty
- 1 year limited parts warranty

## EXCLUSIVE DESIGN

- The exclusive TankSaver design aids the glass lining process to ensure optimum coverage, and guards tank openings for watertight connections

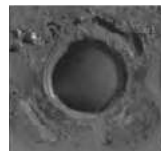

Without TankSaver®

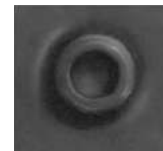

With TankSaver®

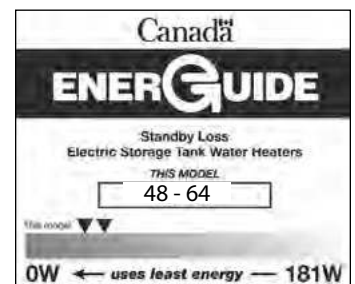

For Technical Information call 888-599-2837. A. O. Smith Enterprises Ltd. reserves the right to make product changes or improvements without prior notice.

SE306N (01-23)





# Residential Electric Water Heaters

SPECIFICATIONS														
Model	Series	Capacity			Input		Recovery Rate at 90°F Temperature Rise	Standby Loss	Height	Diameter*		Width	Shipping Weight	BC/ON/QC Compliant
		IG	USG	L	WATTS	VOLTS				GPH (LPH)	WATTS			
<b>TOP ENTRY SINGLE ELEMENT MODELS</b>														
SS025SE15	100	2	2.5	9	1440	120**	7 (26)	N/A	14 ½ (37)	10 ⅜ (26)	11 ¾ (30)	17 (8)	√	
SS04SE15	100	3	4	15	1440	120**	7 (26)	N/A	19 ¼ (49)	10 ⅜ (26)	11 ¾ (30)	20 (9)	√	
<b>BOTTOM ENTRY SINGLE ELEMENT MODELS</b>														
SS06SEB15	N/A	5	6	23	1500	120	7 (26)	N/A	15 ¼ (39)	14 ¼ (36)	N/A	35 (16)	√	
SS06SEB30	N/A	5	6	23	3000+	240	14 (53)	N/A	15 ¼ (39)	14 ¼ (36)	N/A	35 (16)	√	
SS12SEB15	N/A	10	12	45	1500	120	7 (26)	N/A	22 ¾ (58)	16 (41)	N/A	55 (25)	√	
SS12SEB30	N/A	10	12	45	3000+	240	14 (53)	N/A	22 ¾ (58)	16 (41)	N/A	55 (25)	√	
SS620SSEB-15K	100	14	17	65	1500	120	7 (26)	51	25 ½ (65)	20 (51)	N/A	65 (30)	√	
SS620SSEB-30	100	14	17	65	3000+	240	14 (53)	51	25 ½ (65)	20 (51)	N/A	65 (30)	√	
SS630SSEBN-15K	100	22	27	102	1500	120	7 (26)	48	30 (76)	22 (56)	N/A	101 (46)	√	
SS630SSEBN-30	100	22	27	102	3000+	240	14 (53)	48	30 (76)	22 (56)	N/A	101 (46)	√	
<b>TOP ENTRY DOUBLE ELEMENT MODELS</b>														
SS640SDE3-15K	100	32	38	144	1500	120	7 (26)	54	50 (127)	20 (51)	N/A	103 (47)	√	
SS640SDE3-30X	100	32	38	144	3000	208	14 (53)	54	50 (127)	20 (51)	N/A	103 (47)	√	
SS640SDE3-30	100	32	38	144	3000+	240	14 (53)	54	50 (127)	20 (51)	N/A	103 (47)	√	
<b>LOWBOY TOP ENTRY DOUBLE ELEMENT MODELS</b>														
SS630LDE-45X	250	22	27	102	4500	208	20 (76)	53	31 (79)	22 (56)	N/A	96 (44)	ON/QC only	
SS630LDE-45	250	22	27	102	4500**	240	20 (76)	53	31 (79)	22 (56)	N/A	96 (44)	ON/QC only	
SS640LDE-45X	250	30	36	137	4500	208	20 (76)	62	33 ½ (85)	24 (61)	N/A	113 (51)	ON/QC only	
SS640LDE-45	250	30	36	137	4500**	240	20 (76)	62	33 ½ (85)	24 (61)	N/A	113 (51)	ON/QC only	
SS650LDEN-45	280	40	48	181	4500	240	20 (76)	64	37 ¾ (96)	26 ½ (67)	N/A	170 (77)	-	

\*Depth on model SS025SE15 and SS04SE15.

\*\*Plug-in model.

\*Model is dual-rated. At 208V wattage is 2253.

\*\*Model is dual-rated. At 208V wattage is 3380.

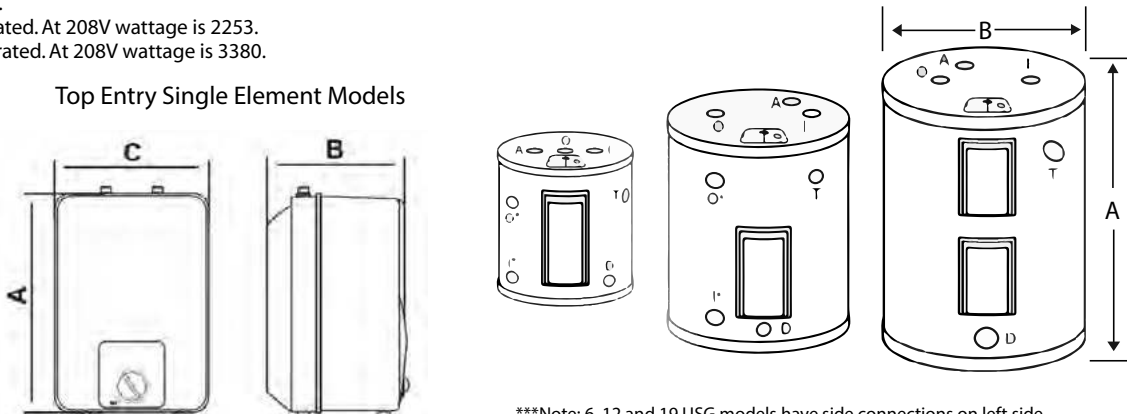

\*\*\*Note: 6, 12 and 19 USG models have side connections on left side.

For Technical Information call 888-599-2837. A. O. Smith Enterprises Ltd. reserves the right to make product changes or improvements without prior notice.

**SE306N (01-23)**

## ProLine® XE HEAT PUMP

The ProLine® XE heat pump water heaters from A. O. Smith are a cost effective energy-efficient option available for consumers who want to save money on their electric utility bills.

### HOW DO THEY WORK?

- Absorbs ambient heat from the surrounding air to heat water using a compressor and environmentally-friendly R134a refrigerant
  - Self-contained heat pump unit is integrated into the top of the tank
  - Multiple operating modes to maximize efficiency and performance

### INCREASED ENERGY EFFICIENCY

- Improved efficiency design to ensure available hot water at the lowest possible cost
- Up to a 3.45 Uniform Energy Factor (UEF) conserves energy and exceeds ENERGY STAR® qualifications

### CHOICE OF OPERATING MODES

- Select from Efficiency, Hybrid, or Electric modes to match heating requirements to environmental conditions
- Hybrid mode automatically adjusts between compressor and element, depending upon heat requirements
- Vacation mode reduces operating costs and provides freeze protection during extended absence

### BACKUP ELECTRIC ELEMENTS

- Long-lasting backup heating elements help heat water according to environmental conditions, demand, and the chosen operating mode

### COREGARD™ ANODE ROD

- Anode rods have a stainless steel core that extends the life of the anode rod allowing superior tank protection far longer than standard anode rods
- 66 and 80 gallon models have dual anodes for added protection

### DRY FIRE PROTECTION

- Control system checks to ensure the tank is full of water during start up to prevent dry firing the heating elements

### ELECTRONIC USER INTERFACE

- User-friendly electronic interface allows easy control of temperature setting, operating mode, and communicates diagnostics
- Easy to read temperature display (see back) shows temperature in °F or °C
- Advanced diagnostics convey error messages for service purposes and the last four error messages are saved in the control system memory

### COMMERCIAL-GRADE

- ProLine® XE Heat Pump are residential water heaters with commercial grade quality

### OTHER FEATURES

- Ideal for basement installations; the compressor transfers heat to the water while dehumidifying and cooling the ambient air
- Washable air filter is easily removed for routine cleaning

### OPTIONAL DUCTING

- Permits installation in confined spaces
- Duct up to 50 feet with air duct adapter kit
- Duct up to 100 feet with air duct adapter and booster fan kits

### WARRANTY

- 10 year limited tank and parts warranty
- For complete information, consult written warranty or A. O. Smith



# Commercial-Grade Residential Water Heaters

## PERFORMANCE

MODEL	SERIES	NOMINAL CAPACITY USG (L)	INPUT		UNIFORM ENERGY FACTOR HYBRID MODE	FIRST HOUR RATING HYBRID MODE GPH (LPH)
			WATTS UPPER/LOWER	VOLTS		
HPTU-50N	130	50 (189)	4500/4500	208/240	3.45	66 (249)
HPTU-66N	130	66 (250)	4500/4500	208/240	3.45	79 (299)
HPTU-80N	130	80 (303)	4500/4500	208/240	3.45	86 (325)

Requires 30 amp breaker.  
Top T&P option not available.

## DIMENSIONS & SHIPPING WEIGHT

MODEL	INSTALLATION HEIGHT	TANK DIAMETER	HEIGHT TO UPPER SIDE CONNECTION	HEIGHT TO LOWER SIDE CONNECTION	HEIGHT TO DRAIN VALVE	HEIGHT TO T&P	SHIPPING WEIGHT
	A IN (CM)	B IN (CM)	C IN (CM)	D IN (CM)	D IN (CM)	E IN (CM)	LB (KG)
HPTU-50N	63 (160)	22 (56)	40 5/8 (103)	3 3/4 (10)	3 3/4 (10)	40 1/2 (103)	196 (89)
HPTU-66N	61 (155)	27 (69)	38 (97)	4 (10)	4 (10)	38 (97)	289 (131)
HPTU-80N	69 (175)	27 (69)	46 (117)	4 (10)	4 (10)	46 (117)	307 (139)

## ELECTRONIC USER INTERFACE

- User friendly, easy to read display
- LEDs clearly indicate the current operating mode
- Easily select operating mode:
  - Efficiency
  - Hybrid
  - Electric
  - Vacation
- Display communicates current status, mode and set point, and displays error messages when applicable



## EFFICIENCY MODE

- Utilizes the heat pump for all water heating

## HYBRID MODE

- Automatically reverts to heating element if ambient air or water temperatures are outside optimal operating range for heat pump
- Utilizes the heat pump or heating element, depending on demand

## ELECTRIC MODE

- Standard electric water heater operation

## VACATION MODE

- One touch operation maintains tank temperature of 60°F (15.6°C) during vacation or extended absence to reduce operating costs and provide freeze protection
- Programmable up to 99 days

## OPTIONAL ACCESSORIES

- 100234320 Inlet and Outlet Air Duct Kit
- 100131328 Booster Fan Kit

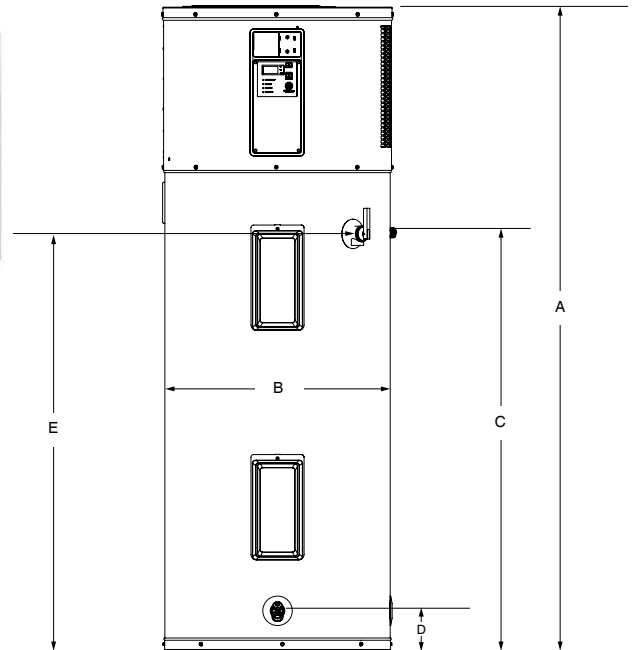

## OTHER FEATURES:

- Environmentally-friendly non-CFC foam insulation
- Durable, enhanced-flow tamper-resistant brass drain valve
- 51 dBA decibel level during operation
- CSA certified and ASME rated temperature & pressure relief valve

## OPERATING REQUIREMENTS:

- Requires provision for condensate draining; if a suitable drain is not available, a condensate pump is required
- 208/240 VAC 60Hz single phase 30 amp power supply

For Technical Information call 888-599-2837. A. O. Smith Enterprises Ltd. reserves the right to make product changes or improvements without prior notice.

## ProLine® & ProLine® Master ATMOSPHERIC VENT

### DESIGNED FOR PERFORMANCE

- ProLine® and ProLine® Master models are residential water heaters with commercial-grade quality
- DynaClean™ diffuser dip tube helps reduce lime and sediment buildup, maximizes hot water output and is made from long-lasting PEX cross-linked polymer
- Thermopile design provides robust pilot to withstand down drafts and environmental conditions
- Easy temperature adjustments
- Robust 1/4" pilot tubing
- Blue Diamond® glass coating protects steel tank from corrosion and maximizes tank life
- 3/4" side taps on 75 gallon model for combination applications

### SAFETY FEATURES

- If flammable vapours accidentally enter the combustion chamber, the arrestor is designed so flames burn off the top surface and can not escape down through the arrestor

### SERVICEABILITY

- Easy-to-access combustion chamber
- Conveniently located T&P and drain valve for ease of installation and serviceability
- Piezoelectric ignitor allows for push-button pilot lighting
- CoreGard™ magnesium anode with a stainless steel core protects the tank against corrosion
- LED indicator:
  - gives visual confirmation that pilot is on by flashing continuously
  - provides diagnostics and troubleshooting

### WARRANTY

- 6 year limited tank and parts warranty on ProLine® models
- 8 year limited tank and parts warranty on ProLine® Master models
- 2 and 4 year tank warranty extension kits are available for 6 year models (except FCG-75)

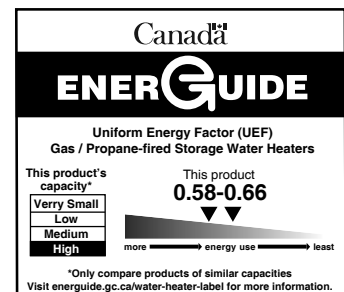

## PERFORMANCE

MODEL	SERIES	CAPACITY	INPUT †	MAXIMUM CERTIFIED ALTITUDE	RECOVERY RATE AT 90°F TEMPERATURE RISE	FIRST HOUR RATING	ENERGY FACTOR	UEF	WARRANTY TANK/PARTS
		USG (L)	BTU/h	FT (M)	GPH (LPH)	GPH (LPH)			YEARS
<b>NATURAL GAS</b>									
GCRL 30R	400/401	30 (114)	32,000	10,100 (3,078)	32 (121)	55 (208)	0.64	0.60	6/6
GCRL 40	400/401	40 (151)	40,000	10,100 (3,078)	41 (155)	67 (254)	0.62	0.58	6/6
GCR 40	400/401	40 (151)	40,000	10,100 (3,078)	42 (159)	70 (265)	0.62	0.66	6/6
GCRL 50	400/401	50 (189)	40,000	10,100 (3,078)	43 (163)	93 (352)	0.61	0.62	6/6
GCR 50	400/401	50 (189)	40,000	10,100 (3,078)	42 (159)	88 (333)	0.62	0.62	6/6
GVRT 60	400/401	60 (227)	52,200	10,100 (3,078)	54 (204)	104 (394)	0.59	0.59	6/6
FCG 75L*	400/401	75 (284)	75,100	7,700 (2,347)	80 (303)	125 (473)	N/A	0.60	6/6
<b>NATURAL GAS</b>									
HWRL 40	400/401	40 (151)	40,000	10,100 (3,078)	41 (155)	67 (254)	0.62	0.62	8/8
HWRL 50	400/401	50 (189)	40,000	10,100 (3,078)	43 (163)	93 (352)	0.61	0.61	8/8

Natural gas models are series 400. Propane models are series 401. All models comply with national energy efficiency regulations.

\* Model has side connections.

† Propane Gas – 36,000 for the 50 gallon short, 37,000 for the 50 gallon tall, 36,000 for 40 gallon models and 29,000 input for 30 gallon models.

## DIMENSIONS & SHIPPING WEIGHT

MODEL	INSTALLATION HEIGHT	HEIGHT TO TOP OF TANK	TANK DIAMETER	HEIGHT TO GAS INLET	COLD CONNECTION TO HOT CONNECTION	HEIGHT TO T&P	DRAFTHOOD CONNECTOR DIAMETER	SHIPPING WEIGHT
	A IN (CM)	B IN (CM)	C IN (CM)	D IN (CM)	E IN (CM)	F IN (CM)	IN	LB (KG)
GCRL 30R	50 ¼ (128)	46 ¾ (119)	20 (51)	14 (35)	8 (20)	40 (102)	3 or 4	108 (49)
GCRL 40 / HWRL 40	51 ½ (131)	47 ¾ (121)	22 (56)	13 (33)	8 (20)	41 (104)	3 or 4	135 (61)
GCR 40	61 ¾ (157)	58 ¾ (148)	20 (51)	13 (33)	8 (20)	51 ¾ (131)	3 or 4	150 (68)
GCRL 50 / HWRL 50	53 ¾ (135)	49 ½ (126)	24 (61)	13 (33)	8 (20)	42 ½ (108)	3 or 4	175 (79)
GCR 50	61 (155)	57 ¾ (145)	22 (56)	13 (33)	8 (20)	50 ¼ (128)	4	165 (75)
GVRT 60	62 ¾ (159)	59 (150)	24 (61)	13 (33)	8 (20)	51 ½ (131)	4	205 (93)
FCG 75L*	61 (155)	57 ¾ (145)	26 ½ (67)	14 ¾ (37)	8 (20)	50 ¼ (128)	4	273 (124)

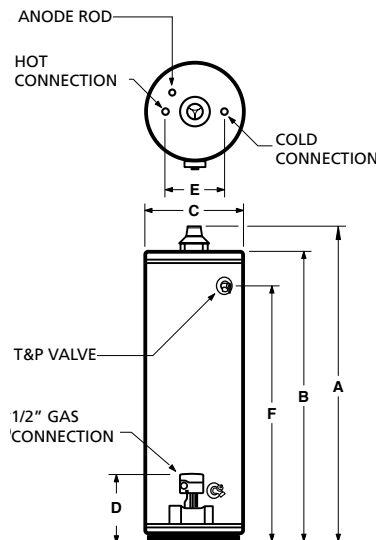
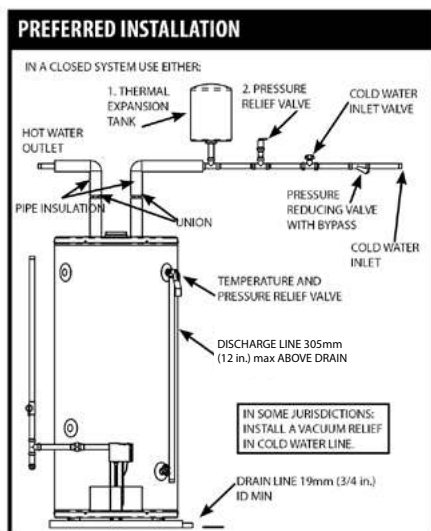

For Technical Information call 888-599-2837. A. O. Smith Enterprises Ltd. reserves the right to make product changes or improvements without prior notice.

## ProLine® XE ATMOSPHERIC VENT

### ENERGY SAVINGS

- Exceeds NRCan energy efficiency requirements
- Built-in heat traps on the water inlet and outlet reduce the amount of heat lost through piping

### DESIGNED FOR PERFORMANCE

- ProLine® XE models are residential water heaters with commercial-grade quality
- The electronic gas control incorporates an LED status indicator that monitors system operation and service diagnostics
- Operates with an automatic pilot relight system that shuts off the pilot during stand-by modes to reduce gas consumption and eliminates nuisance pilot outage issues associated with standing pilot models
- Plugs into standard 110/120v outlet (10 foot power cord included)
- Blue Diamond® glass coating provides superior corrosion resistance to industry-standard glass lining
- Design certified by CSA International according to ANSI Z21.10.1 - 4.1 CSA Standards governing storage-type water heaters

### DynaClean™ DIFFUSER DIP TUBE

- Helps reduce lime and sediment buildup, maximizes hot water output and is made from long-lasting PEX cross-linked polymer

### SERVICEABILITY

- CoreGard™ magnesium anode with stainless steel core protects the tank against corrosion
- Durable brass tamper-resistant drain valve
- Conveniently located CSA certified and ASME rated T&P relief valve
- Top mounted T&P relief valve available as an option on all models

### SAFETY FEATURES

- Flammable vapour ignition resistant compliant design

### WARRANTY

- 6 year tank and parts warranty

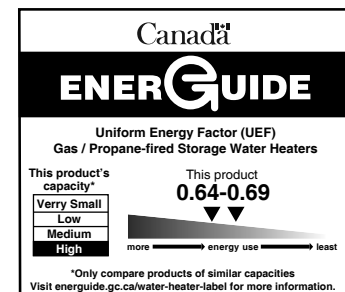

# Commercial-Grade Residential Water Heaters

## PERFORMANCE

MODEL	SERIES	CAPACITY	INPUT*	MAXIMUM CERTIFIED ALTITUDE	RECOVERY RATE AT 90°F TEMPERATURE RISE	FIRST HOUR RATING	UEF	WARRANTY TANK/PARTS
		USG (L)	BTU/h	FT (M)	GPH (LPH)	GPH (LPH)		YEARS
<b>NATURAL GAS</b>								
GCFL 40	100/101	40 (151)	40,000	10,100 (3,078)	41 (155)	67 (254)	0.66	6/6
GCF 40	100/101	40 (151)	40,000	10,100 (3,078)	41 (155)	67 (254)	0.64	6/6
GCFL 50	100	50 (189)	40,000	10,100 (3,078)	41 (155)	81 (307)	0.69	6/6
GCF 50	100/101	50 (189)	40,000	10,100 (3,078)	41 (155)	81 (307)	0.69	6/6

Recovery capacity based on actual performance tests.

Water Connections - 3/4" on all models.

External heat trap nipples are factory-installed on all models.

Natural gas models are series 100. Propane models are series 101. All models comply with national energy efficiency regulations.

\*Propane (LP) gas - 37,000 BTU input for 50-gallon model and 36,000 BTU for 40-gallon model.

GCFL 50 not available for Propane.

## DIMENSIONS & SHIPPING WEIGHT

MODEL	INSTALLATION HEIGHT	HEIGHT TO TOP OF TANK	DIAMETER	HEIGHT TO GAS INLET	HOT CONNECTION TO COLD CONNECTION	HEIGHT TO T&P	DRAFTHOOD CONNECTOR DIAMETER	SHIPPING WEIGHT
	A IN (CM)	B IN (CM)	C IN (CM)	D IN (CM)	E IN (CM)	F IN (CM)	IN	LB (KG)
<b>NATURAL GAS</b>								
GCFL 40	54 (137)	47 ¾ (121)	22 (56)	13 (33)	8 (20)	41 (104)	3 or 4	149 (68)
GCF 40	64 ¼ (163)	58 ¼ (148)	20 (51)	13 (33)	8 (20)	51 ¾ (131)	3 or 4	152 (69)
GCFL 50	55 ¾ (142)	49 ½ (126)	24 (61)	13 (33)	8 (20)	42 ½ (108)	3 or 4	183 (83)
GCF 50	63 ½ (161)	57 ¼ (145)	22 (56)	13 (33)	8 (20)	50 ¼ (128)	3 or 4	167 (76)

## PREFERRED INSTALLATION

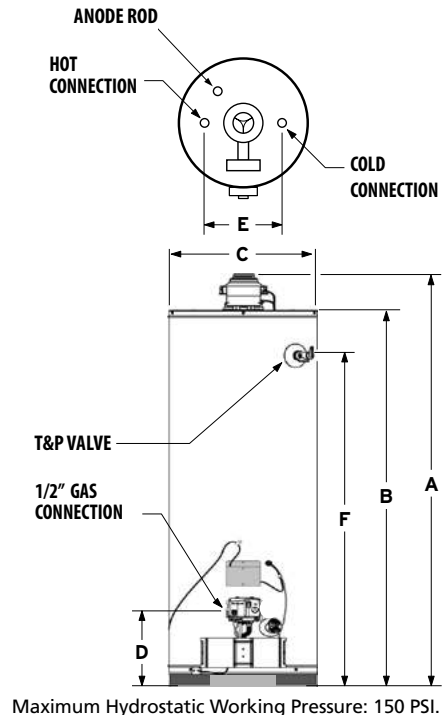
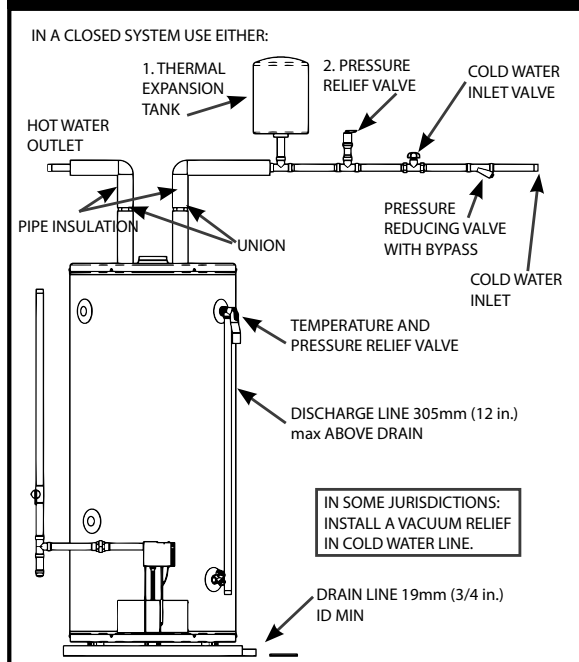

For Technical Information call 888-599-2837. A. O. Smith Enterprises Ltd. reserves the right to make product changes or improvements without prior notice.

## ProLine® XE POWER VENT

### ENERGY SAVINGS

- Industry-leading energy efficient power vent, with up to a 0.73 UEF
- 2" CFC-free foam insulation to improve energy efficiency
- Built-in heat traps on the water inlet and outlet reduce the amount of heat lost through piping
- Exceeds NRCan energy efficiency standards

### DESIGNED FOR PERFORMANCE

- ProLine® XE models are residential water heaters with commercial-grade quality
- Convenient 3/4" side taps for combination applications on 50 USG high-input and 75 USG models
- Suitable for elevations up to 10,100 ft. (3,078 m)
- Available for both natural gas or propane
- Blue Diamond® glass coating protects steel tank from corrosion and maximizes tank life

### SAFETY FEATURES

- Sensor detects the presence of flammable vapours and automatically disables the unit, preventing their ignition
- Robust air intake snorkel inhibits flammable vapours from entering the combustion chamber

### SERVICEABILITY

- State-of-the-art electronic gas control

features advanced self-diagnostic capability that makes troubleshooting easy

- Conveniently located T&P and drain valve for ease of installation and serviceability

### THE ULTIMATE IN VENTING FLEXIBILITY

- Can be vented with 2", 3" or 4" ULC S636 PVC, CPVC or polypropylene pipe
- Vertical or horizontal venting configurations

### WARRANTY

- 6 year limited tank and parts warranty
- 8 year limited tank and parts warranty models also available
- 2 and 4 year tank warranty extension kits are available for 6 year models

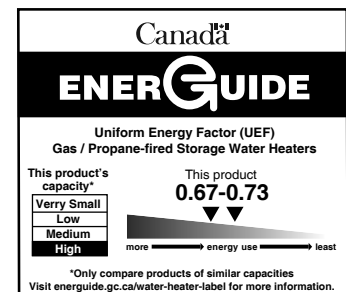



## PERFORMANCE

MODEL	SERIES	CAPACITY	INPUT	MAXIMUM CERTIFIED ALTITUDE	RECOVERY RATE AT 90°F TEMPERATURE RISE	FIRST HOUR RATING	UEF	WARRANTY TANK/PARTS
		USG (L)	BTU/h	FT (M)	GPH (LPH)	GPH (LPH)		YEARS
<b>NATURAL GAS</b>								
GPVL 40	200/201	40 (151)	40,000	10,100 (3,078)	44 (167)	73 (276)	0.67	6/6
GPVT 40	200/201	40 (151)	50,000	10,100 (3,078)	50 (189)	90 (341)	0.70	6/6
GPVL 50	200/201	50 (189)	40,000	10,100 (3,078)	44 (167)	90 (341)	0.72	6/6
GPVT 50	200/201	50 (189)	50,000	10,100 (3,078)	50 (189)	96 (363)	0.72	6/6
GPVX 50L*	200/201	50 (189)	62,000	10,100 (3,078)	69 (261)	110 (416)	0.73	6/6
GPVL 60	200/201	60 (227)	42,000	10,100 (3,078)	46 (174)	106 (401)	0.69	6/6
GPVX 75L*	200/201	75 (284)	72,000	10,100 (3,078)	80 (303)	155 (587)	0.69	6/6
<b>NATURAL GAS</b>								
HPVL 50	200/201	50 (189)	40,000	10,100 (3,078)	44 (167)	90 (341)	0.72	8/8
HPVX 50L*	200/201	50 (189)	62,000	10,100 (3,078)	69 (261)	110 (416)	0.73	8/8

Natural gas models are series 200. Propane models are series 201.  
 All models comply with national energy efficiency regulations.  
 \* Model has side connections

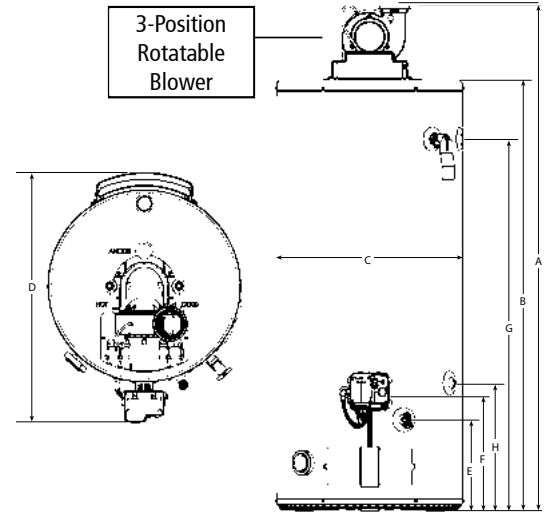

## DIMENSIONS & SHIPPING WEIGHT

MODEL	INSTALLATION HEIGHT	HEIGHT TO TOP OF TANK	TANK DIAMETER	OVERALL DEPTH	HEIGHT TO DRAIN VALVE	HEIGHT TO GAS INLET	HEIGHT TO T&P	HEIGHT TO UPPER SIDE CONNECTION	HEIGHT TO LOWER SIDE CONNECTION	SHIPPING WEIGHT
	A IN (CM)	B IN (CM)	C IN (CM)	D IN (CM)	E IN (CM)	F IN (CM)	G IN (CM)	G IN (CM)	H IN (CM)	LB (KG)
<b>NATURAL GAS</b>										
GPVL 40	59 (150)	49 5/8 (126)	22 (56)	29 1/8 (74)	11 (28)	13 1/4 (34)	42 1/2 (108)	N/A	N/A	174 (79)
GPVT 40	68 1/2 (174)	59 1/4 (150)	20 (51)	27 1/8 (69)	11 (28)	13 1/4 (34)	53 1/8 (135)	N/A	N/A	176 (80)
GPVL 50 / HPVL 50	60 1/8 (153)	50 3/4 (129)	24 (61)	31 1/8 (79)	11 (28)	13 1/4 (34)	43 3/4 (111)	N/A	N/A	198 (90)
GPVT 50	68 1/8 (173)	58 3/4 (149)	22 (56)	29 1/8 (74)	11 (28)	13 1/4 (34)	51 3/4 (131)	N/A	N/A	192 (87)
GPVX 50L / HPVX 50L	61 1/8 (155)	52 (132)	24 (61)	31 1/8 (79)	11 (28)	13 1/4 (34)	44 1/2 (113)	44 1/2 (113)	15 1/4 (39)	212 (96)
GPVL 60	67 1/4 (171)	57 7/8 (147)	24 (61)	31 1/8 (79)	11 (28)	13 1/4 (34)	50 3/8 (128)	N/A	N/A	216 (98)
GPVX 75L	70 5/8 (179)	61 1/4 (156)	26 (66)	33 1/8 (84)	11 (28)	13 1/4 (34)	53 (135)	53 (135)	15 1/4 (39)	277 (126)

## PREFERRED INSTALLATION

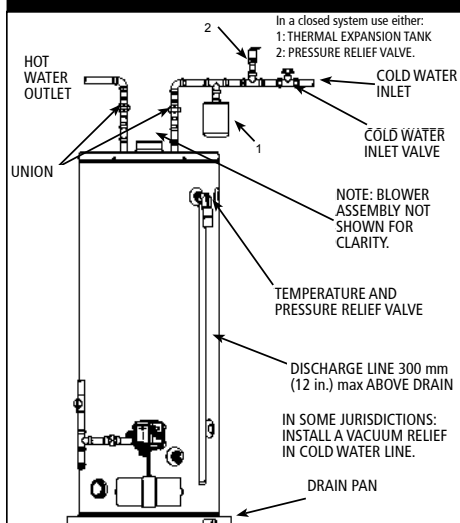

## VENT PIPE LENGTHS

MODEL	VENT PIPE DIAMETER IN	MINIMUM NUMBER OF ELBOWS REQUIRED*	MAXIMUM VENT LENGTH WITH ONE 90° ELBOW FT (M)	MINIMUM VENT LENGTH WITH ONE 90° ELBOW FT (M)
GPVL 40	2	0	50 (15.2)	7 (2.1)
GPVT 40				
GPVL 50 / HPVL 50	3	0	125 (38.1)	50 (15.2)
GPVT 50				
GPVL 60	4	0	180 (54.9)	125 (38.1)
GPVX 50L / HPVX 50L	3	0	50 (15.2)	7 (2.1)
GPVX 75L				
	4	0	125 (38.1)	50 (15.2)

\* Refer to installation manual for further details.

## VENT KITS

DESCRIPTION	PART NUMBER
3" Vent Kit Includes coupling for blower outlet and termination screens	100112701
4" Vent Termination Kit Includes termination screens	100112700

For Technical Information call 888-599-2837. A. O. Smith Enterprises Ltd. reserves the right to make product changes or improvements without prior notice.

## ProLine® XE POWER DIRECT VENT

### ENERGY SAVINGS

- Exceeds NRCAN energy efficiency standards
- Factory-installed heat trap nipples

### DESIGNED FOR PERFORMANCE

- ProLine® XE are residential water heaters with commercial grade quality
- Compact design – ideal as a replacement water heater and for closet installations
- Ultra-quiet blower
- Convenient 3/4" side water connections for combination applications on high input 50 USG and 75 USG units (plugs are factory-installed)
- Suitable for altitudes up to 10,100 ft. (3,078 m)
- Factory-installed T&P valve and drip tube
- Blue Diamond® glass coating protects steel tank from corrosion and maximizes tank life

### SAFETY FEATURES

- Sealed combustion chamber design, eliminating the need for a flammable vapour sensor
- Zero clearance to combustibles

### SERVICEABILITY

- State-of-the-art gas control features advanced self diagnostic capability that makes troubleshooting easy
- Conveniently located T&P and drain valve for ease of serviceability
- Auto-reset temperature switch monitors vent temperature

### THE ULTIMATE IN VENTING FLEXIBILITY

- Can be vented with 2", 3" or 4" ULC S636 PVC, CPVC or polypropylene pipe up to 180 equivalent feet (see installation manual for full details)
- Can be installed using a concentric vent kit (see reverse or installation manual for details)

### WARRANTY

- 6 year limited tank and parts warranty
- 2 or 4 year tank warranty extension kits available

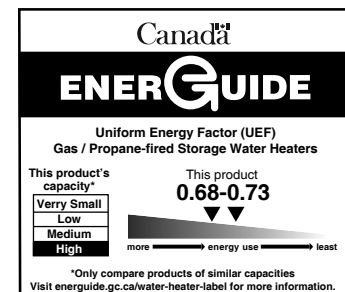

# Commercial-Grade Residential Water Heaters

## PERFORMANCE

MODEL	SERIES	CAPACITY	INPUT	RECOVERY RATE AT 90°F TEMPERATURE RISE	FIRST HOUR RATING	UEF	WARRANTY TANK/PARTS
		USG (L)	BTU/h	GPH (LPH)	GPH (LPH)		YEARS
<b>NATURAL GAS</b>							
GPDL 40	300/301	40 (151)	40,000	44 (167)	71 (269)	0.68	6/6
GPDT 50	300/301	50 (189)	45,000	50 (189)	93 (352)	0.72	6/6
GPDX 50L*	300/301	50 (189)	62,000	67 (254)	100 (379)	0.73	6/6
GPDX 75L*	300/301	75 (284)	72,000	82 (310)	154 (583)	0.68	6/6

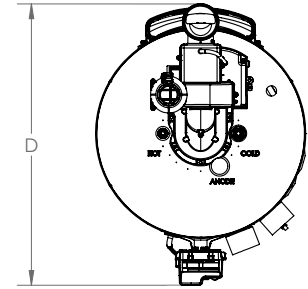

All models rated for installation at altitudes up to 10,100 ft (3,078 m).

Natural gas models are series 300. Propane models are series 301. All models comply with national energy efficiency regulations.

\*Side connections.

## DIMENSIONS & SHIPPING WEIGHT

MODEL	INSTALLATION HEIGHT	HEIGHT TO TOP OF TANK	TANK DIAMETER	OVERALL DEPTH	HEIGHT TO DRAIN VALVE	HEIGHT TO GAS INLET	HEIGHT TO T&P	HEIGHT TO UPPER SIDE CONNECTION	HEIGHT TO LOWER SIDE CONNECTION	VENT DIAMETER	SHIPPING WEIGHT
	A IN (CM)	B IN (CM)	C IN (CM)	D IN (CM)	E IN (CM)	F IN (CM)	G IN (CM)	G IN (CM)	H IN (CM)	IN	LB (KG)
<b>NATURAL GAS</b>											
GPDL 40	58 ¼ (148)	49 ½ (126)	22 (56)	29 7/8 (76)	11 (28)	13 ¼ (34)	42 5/8 (108)	N/A	N/A	2, 3 or 4	174 (79)
GPDT 50	67 ½ (171)	58 7/8 (150)	22 (56)	29 7/8 (76)	11 (28)	13 ¼ (34)	51 ¾ (131)	N/A	N/A	2, 3 or 4	192 (87)
GPDX 50L	68 7/8 (175)	60 ¼ (153)	22 (56)	29 7/8 (76)	11 (28)	13 ¼ (34)	52 ¾ (134)	52 ¾ (134)	15 ¼ (39)	3 or 4	200 (91)
GPDX 75L	70 5/8 (179)	60 ½ (154)	26 (66)	33 7/8 (86)	11 (28)	13 ¼ (34)	53 (135)	53 (135)	15 ¼ (39)	3 or 4	277 (126)

## VENT PIPE LENGTHS

MODEL	VENT PIPE DIAMETER IN	MINIMUM NUMBER OF ELBOWS REQUIRED*	MINIMUM VENT LENGTH WITH ONE ELBOW FT (M)		MAXIMUM EQUIVALENT VENT LENGTH FT (M)		
			CONCENTRIC	2 PIPE	CONCENTRIC	2 PIPE	
			GPDL 40	2	1	7 (2)	7 (2)
GPDL 40	3	1	7 (2)	7 (2)	100 (30)	125 (38)	
	4	1	N/A	50 (15)	N/A	180 (55)	
	GPDT 50	2	1	7 (2)	7 (2)	50 (15)	50 (15)
GPDT 50	3	1	7 (2)	7 (2)	100 (30)	125 (38)	
	4	1	N/A	50 (15)	N/A	180 (55)	
	GPDX 50L	3	1	7 (2)	7 (2)	45 (14)	50 (15)
GPDX 50L	4	1	N/A	50 (15)	N/A	125 (38)	
	GPDX 75L	3	1	7 (2)	7 (2)	30 (9)	50 (15)
	4	1	N/A	50 (15)	N/A	125 (38)	

\*Refer to installation manual for further details.

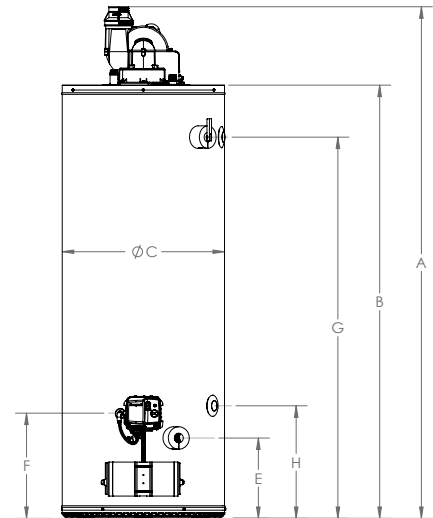

## OPTIONAL KITS

DESCRIPTION	PART NUMBER
2" concentric vent kit	100112869
3" concentric vent kit	100111100
High ambient kit	100308923

For Technical Information call 888-599-2837. A. O. Smith Enterprises Ltd. reserves the right to make product changes or improvements without prior notice.

## ProLine® DIRECT VENT

### DESIGNED FOR PERFORMANCE

- ProLine® models are residential water heaters with commercial-grade quality
- Thermopile design provides robust pilot to withstand down drafts and environmental conditions
- Easy temperature adjustments
- 90" coaxial vent supplied with water heater
- CoreGard™ magnesium anode with a stainless steel core protects the tank against corrosion
- Blue Diamond® glass coating protects steel tank from corrosion and maximizes tank life
- Factory-installed plastic-lined nipples with heat traps
- Automatic gas control
- CFC-free foam insulation
- 3/4" side taps standard on 50 USG high input model for combination applications
- Suitable for closet installations

### SAFETY FEATURES

- Sealed combustion chamber design, eliminates the need for a flammable vapor sensor

### SERVICEABILITY

- Easy-to-access combustion chamber
- Conveniently located T&P and drain valve for ease of installation and serviceability
- LED indicator:
  - Gives visual confirmation that pilot is on by flashing continuously
  - Provides diagnostics and troubleshooting
- Piezoelectric ignitor allows for push-button pilot lighting

### WARRANTY

- 6 year limited tank and parts warranty
- 2 and 4 year tank warranty extension kits are available

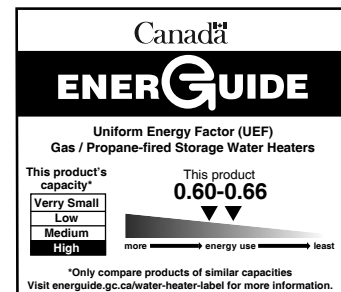

# Commercial-Grade Residential Water Heaters

## PERFORMANCE

MODEL	SERIES	CAPACITY		MAXIMUM CERTIFIED ALTITUDE	RECOVERY RATE AT 90° F TEMPERATURE RISE	FIRST HOUR RATING	UEF	WARRANTY TANK/PARTS	
		USG (L)	BTU/h					FT (M)	GPH (LPH)
GDV 40L	300/301	40 (151)	38,000	7,700 (2,347)	42 (159)	72 (273)	0.60	6/6	
GDV 50L	300/301	50 (189)	40,000	7,700 (2,347)	43 (163)	91 (344)	0.66	6/6	
GDVT 50L*	300/301	50 (189)	47,000	7,700 (2,347)	51 (193)	92 (348)	0.65	6/6	

Natural gas models are series 300. Propane models are series 301. All models comply with national energy efficiency regulations.  
\*Model has side connections.

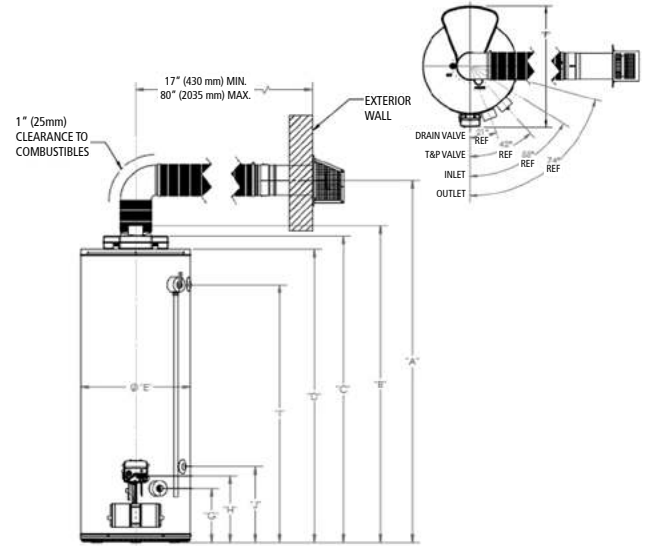

## DIMENSIONS & SHIPPING WEIGHT

MODEL	HEIGHT TO CENTER OF VENT	HEIGHT TO TOP OF FLUE OUTLET	HEIGHT TO TOP OF AIR BOX	HEIGHT TO TOP OF HEATER	DIAMETER	OVERALL DEPTH	HEIGHT TO DRAIN	HEIGHT TO GAS INLET	HEIGHT TO T&P	HEIGHT TO SIDE TAP (HOT OUT)	HEIGHT TO SIDE TAP (COLD IN)	SHIPPING WEIGHT
	A IN (CM)	B IN (CM)	C IN (CM)	D IN (CM)	E IN (CM)	F IN (CM)	G IN (CM)	H IN (CM)	I IN (CM)	I IN (CM)	J IN (CM)	LB (KG)
GDV 40L	64 (163)	54 3/8 (138)	52 1/2 (133)	49 3/8 (126)	22 (56)	29 (74)	10 3/4 (27)	13 1/4 (34)	42 3/8 (108)	N/A	N/A	178 (81)
GDV 50L	73 (185)	63 3/8 (162)	61 3/4 (157)	58 3/8 (150)	22 (56)	29 (74)	10 3/4 (27)	13 1/4 (34)	51 3/8 (131)	N/A	N/A	200 (91)
GDVT 50L*	74 (188)	64 3/8 (164)	62 3/8 (160)	60 (152)	22 (56)	29 (74)	10 3/4 (27)	13 1/4 (34)	52 3/8 (134)	52 3/8 (134)	15 1/4 (39)	215 (98)

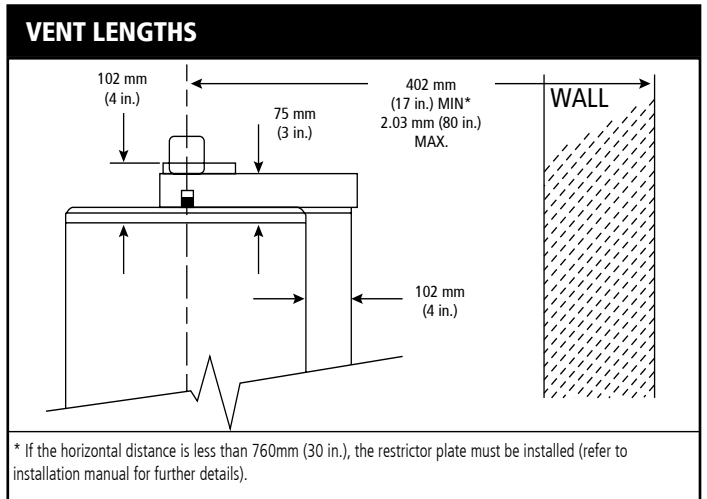
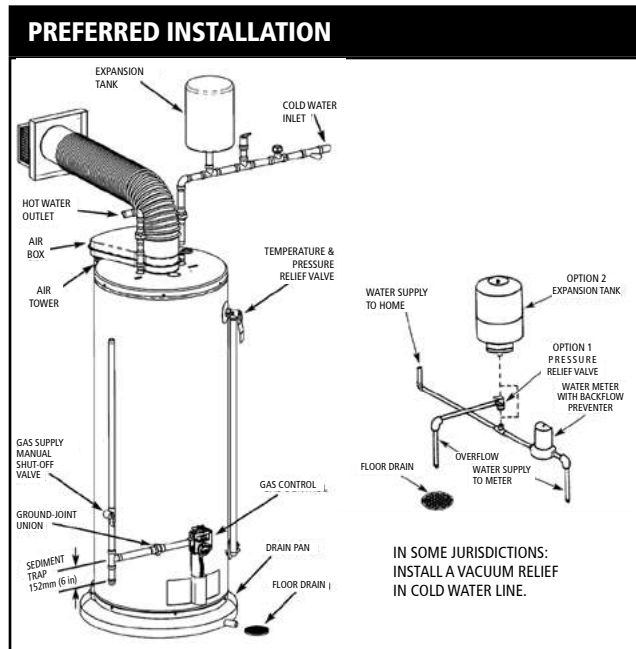

Refer to the installation manual for complete installation and venting requirements.

For Technical Information call 888-599-2837. A. O. Smith Enterprises Ltd. reserves the right to make product changes or improvements without prior notice.

## VERTEX® 94% THERMAL EFFICIENCY VERSATILE POWER VENT DESIGN

Today's homes demand more hot water than ever before, and the 94% efficient Vertex power vent gas water heater offers unprecedented levels of performance to meet the need. The 50-gallon Vertex delivers more hot water than a standard 75-gallon atmospheric gas water heater. In fact, the fully condensing Vertex design is so advanced, it delivers hot water shower after shower...at continuous flow of over 3 gallons per minute.\* Yet Vertex is easy to install, with height, diameter and installation requirements similar to standard power vent units.

### ENERGY STAR® QUALIFIED

#### HELICAL INTERNAL HEAT EXCHANGER

- Spiral heat exchanger keeps hot combustion gases in the tank longer to lengthen the heat transfer cycle
- Positioned in the center of the tank for more even heat distribution
- Operates at 94% thermal efficiency, which saves money on operating costs compared to a standard 78% efficient gas water heater

#### POWER VENT DESIGN

- Combined vertical and horizontal runs terminating through an outside wall using ULC S636 PVC, CPVC, or polypropylene pipe
  - 2" pipe, vents up to 25 equivalent feet
  - 3" pipe, vents up to 65 equivalent feet
  - 4" pipe, vents up to 128 equivalent feet

#### MODULAR BLOWER

- Equipped with 120 volt, 60 Hz electrical system (rating 5 amps or less), 6-foot cord with standard 3-prong connector
- 2" PVC pipe, elbows and condensate drain supplied to connect heat exchanger outlet to blower
- PVC Vent Attenuation Assembly (VAA) supplied

#### SIDE-MOUNTED HOT AND COLD RECIRCULATING TAPS

- Allows Vertex to be installed as part of combination space heating/water heating applications or any system requiring a recirculating hot water loop, including radiant floor heating

#### INTELLI-VENT®\*\* GAS CONTROL

- Equipped with nearly indestructible silicon nitride hot surface ignitor — no standing pilot
- Advanced electronics for more precise control of water temperature and easy to understand system diagnostics

#### BLUE DIAMOND® GLASS COATING TWO HEAVY-DUTY ANODE RODS

- Provide maximum protection against corrosion

#### CSA CERTIFIED AND ASME RATED T&P RELIEF VALVE

#### MAXIMUM HYDROSTATIC WORKING PRESSURE: 150 PSI

#### CODE COMPLIANCE

- Meets the thermal efficiency and standby loss requirements of NRCan and current edition of ASHRAE/IESNA 90.1

#### DESIGN-CERTIFIED BY UNDERWRITERS LABORATORIES

- Certified at 300 PSI test pressure and 150 PSI working pressure. Listed according to ANSI Z21.10.1 - CSA 4.1 standards governing storage tank-type water heaters

#### WARRANTY

- 6 year limited tank warranty
  - 6 year limited parts warranty
- For complete information, consult written warranty or A. O. Smith

\* 3.21 GPM continuous flow, based on 65°F inlet water temperature, 110°F outlet temperature.

\*\*Intelli-Vent® is a registered trademark of Emerson Electric Company



# Residential Condensing Gas Water Heaters

## PERFORMANCE

MODEL	SERIES	CAPACITY		MAXIMUM CERTIFIED ALTITUDE	INPUT	RECOVERY RATE AT 90°F TEMPERATURE RISE	THERMAL EFFICIENCY	UEF	BC COMPLIANT
		USG	L			FT (M)			
<b>NATURAL GAS</b>									
GPHE-50	130	50	189	5,300 (1,615)	76,000	96 (364)	94%	0.88	√

Available in natural gas only.

## DIMENSIONS & SHIPPING WEIGHT

MODEL	INSTALLATION HEIGHT	HEIGHT TO TOP OF TANK	HEIGHT TO T&P	HEIGHT TO UPPER SIDE CONNECTION	HEIGHT TO LOWER SIDE CONNECTION	HEIGHT TO DRAIN VALVE	HEIGHT TO THERMOSTAT	TANK DIAMETER	HOT CONNECTION TO COLD CONNECTION	WATER CONNECTION DEPTH FROM FRONT OF TANK	OVERALL DEPTH	TOP WATER CONNECTIONS	SIDE WATER CONNECTIONS	SHIPPING WEIGHT
	A IN (CM)	B IN (CM)	C IN (CM)	C IN (CM)	D IN (CM)	E IN (CM)	F IN (CM)	G IN (CM)	H IN (CM)	J IN (CM)	K IN (CM)	IN NPT	IN NPT	LB (KG)
<b>NATURAL GAS</b>														
GPHE-50*	71 (180)	68 5/8 (174)	52 (132)	52 (132)	21 (53)	9 1/8 (23)	12 (30)	22 (56)	8 (20)	15 3/4 (40)	27 (69)	3/4	3/4	225 (102)

\*Model has side connections.

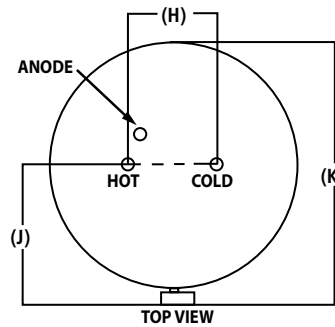
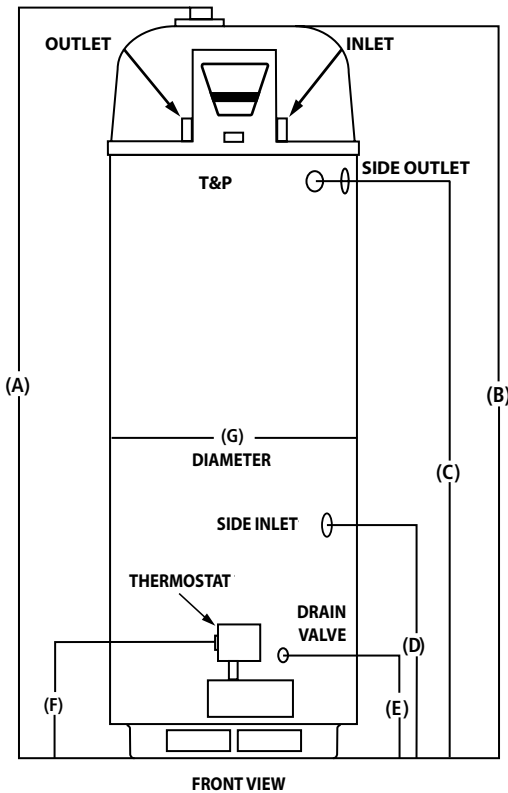

**Install in accordance with local codes**

For Technical Information call 888-599-2837. A. O. Smith Enterprises Ltd. reserves the right to make product changes or improvements without prior notice.

## VERTEX® 96% THERMAL EFFICIENCY

### CONTINUOUS HOT WATER

### VERSATILE POWER DIRECT VENT

Today's homes demand more hot water than ever before, and the 96% efficient Vertex power direct vent gas water heaters offer unprecedented levels of performance to meet the need. The fully condensing Vertex design is so advanced, it delivers hot water shower after shower...at a continuous flow of over 4 gallons per minute.\*

#### ENERGY STAR® QUALIFIED

#### HELICAL INTERNAL HEAT EXCHANGER

- Spiral heat exchanger keeps hot combustion gases in the tank longer to lengthen the heat transfer cycle
- Positioned in the center of the tank for more even heat distribution
- Operates at 96% thermal efficiency, which saves money on operating costs compared to a standard 80% efficient gas water heater

#### POWER DIRECT VENT DESIGN

- Top fired burner
- Combined vertical and horizontal runs terminating through an outside wall using ULC S636 PVC, CPVC or polypropylene pipe
- 2" pipe, vents up to 45 equivalent feet
- 3" pipe, vents up to 128 equivalent feet

#### CONDENSING DESIGN

- 96% efficient condensing design
- Equipped with condensate drain tee

#### SIDE-MOUNTED HOT AND COLD RECIRCULATING TAPS

- Allows Vertex to be installed as part of combination space heating/water heating applications

#### INTELLIGENT CONTROL SYSTEM WITH TOUCH SCREEN DISPLAY

- Exclusive touch display control system
- Precise temperature control
- Advanced diagnostics

#### POWERED ANODES STANDARD

- Provides long-lasting tank protection in varying water conditions
- Powered anodes are non-sacrificial
- Automatically adjusts output needed to properly protect the tank

#### BLUE DIAMOND® GLASS COATING

- Provides superior corrosion resistance compared to industry standard glass lining

#### CSA CERTIFIED AND ASME RATED T&P RELIEF VALVE

#### AVAILABLE IN NATURAL GAS OR PROPANE

#### MAXIMUM HYDROSTATIC WORKING PRESSURE: 150 PSI

#### CODE COMPLIANCE

- Meets the thermal efficiency and standby loss requirements of NRCan and current edition of ASHRAE/IESNA 90.1

#### DESIGN-CERTIFIED BY CSA INTERNATIONAL

- Certified at 300 PSI test pressure and 150 PSI working pressure. Listed according to ANSI Z21.10.3 - CSA 4.3 standards governing storage tank-type water heaters

#### WARRANTY

- 6 year limited tank warranty
- 6 year limited parts warranty

For complete information, consult written warranty or A. O. Smith

Model GDHE-50 \*4.31 GPM continuous flow, based on 65°F inlet water temperature, 110°F outlet temperature.



MODEL SHOWN GDHE-75





## PERFORMANCE

MODEL	SERIES	CAPACITY		MAXIMUM CERTIFIED ALTITUDE	INPUT	RECOVERY RATE AT 90°F TEMPERATURE RISE	THERMAL EFFICIENCY	UEF	BC COMPLIANT
		USG	L						
<b>NATURAL GAS</b>									
GDHE-50	300/301	50	189	10,100 (3,078)	100,000	128 (485)	96%	0.88	√
GDHE-75	300/301	75	284	10,100 (3,078)	100,000	128 (485)	96%	0.86	√

Available in Propane (LP) gas. Specify when ordering Propane (LP) gas.  
 Natural gas models are series 140. Propane models are series 141.  
 Optional Condensate Neutralizer Kit available (Part Number 9007959005).

## DIMENSIONS & SHIPPING WEIGHT

MODEL	HEIGHT TO TOP OF TANK	HEIGHT TO T&P	HEIGHT TO UPPER SIDE CONNECTION	TANK DIAMETER	HEIGHT TO LOWER SIDE CONNECTION	HEIGHT TO DRAIN VALVE	OUTLET TO INLET	TOP WATER CONNECTIONS	SIDE WATER CONNECTIONS	GAS CONNECTION	SHIPPING WEIGHT
	A IN (CM)	B IN (CM)	B IN (CM)	C IN (CM)	D IN (CM)	E IN (CM)	F IN (CM)	IN NPT	IN NPT	IN NPT	LB (KG)
<b>NATURAL GAS</b>											
GDHE-50	66 3/4 (170)	49 1/4 (125)	49 1/4 (125)	22 (56)	15 3/4 (40)	3 (8)	8 (20)	3/4	3/4	1/2	255 (116)
GDHE-75	65 1/4 (166)	45 3/8 (116)	45 3/8 (116)	27 3/4 (71)	16 (41)	3 3/4 (10)	8 (20)	1	3/4	1/2	382 (173)

Inlet and outlet connections: 3/4" male for GDHE-50 and 1" for GDHE-75  
 Circulation loop connections: 3/4" female  
 Gas inlet: 1/2"  
 Maximum supply pressure: 14" W.C. (3.48kPa)  
 Minimum supply pressure for natural gas: 3.50" W.C. (.87kPa)  
 Minimum supply pressure for propane: 8.00" W.C. (1.99kPa)  
 Minimum supply pressure must be maintained under both load and no load (dynamic and static) conditions  
 Electrical characteristics: 120V, 60Hz, amperes <5

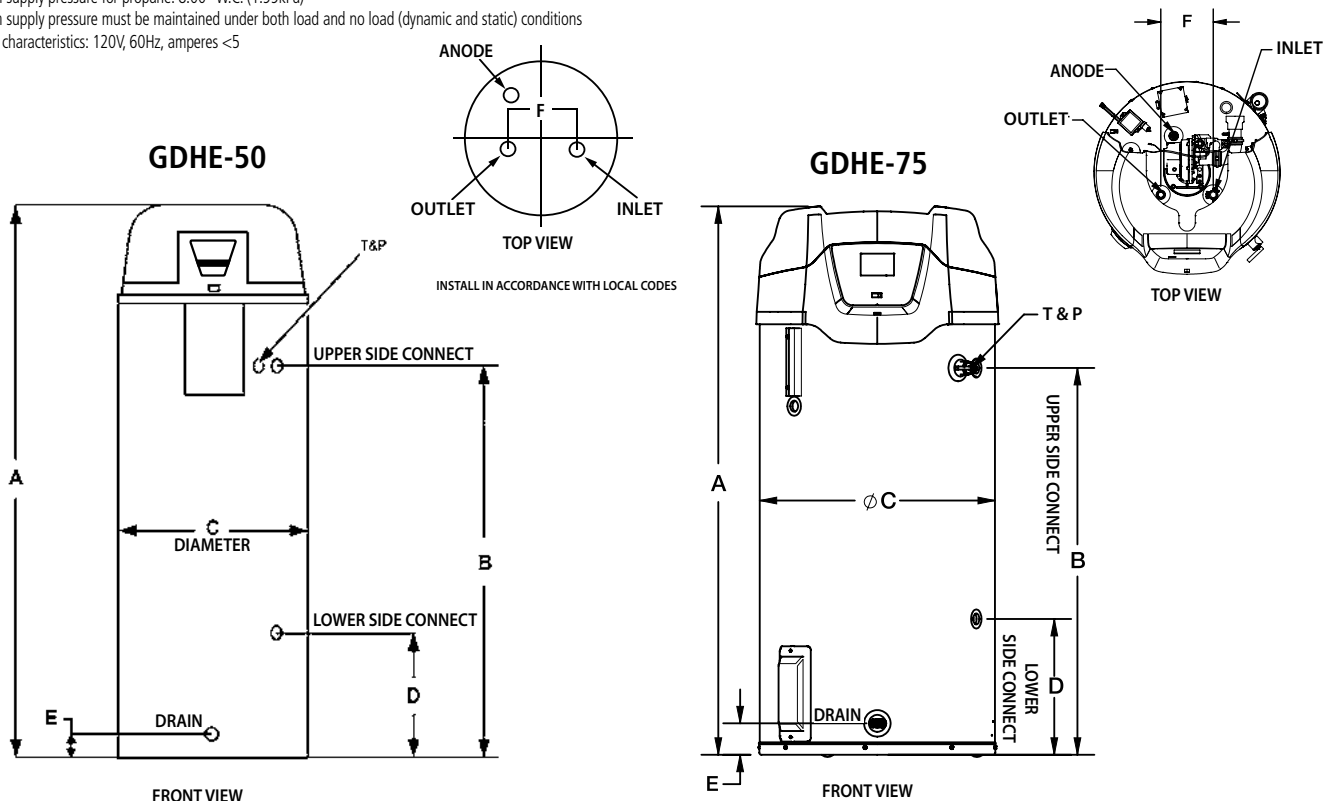

For Technical Information call 888-599-2837. A. O. Smith Enterprises Ltd. reserves the right to make product changes or improvements without prior notice.

## VERTEX® HV

Flexible, Powerful & Highly Efficient Gas Water Heater for the Everyday Home.

Commercial-grade hot water delivery is now more attainable than ever. The Vertex™ HV provides flexible, powerful and highly efficient performance to the everyday home. The fully condensing Vertex design is so advanced, it can deliver “continuous hot water for shower after shower” at a constant flow of over 2.5 gallons per minute.\*

### ENERGY STAR® QUALIFIED

#### ADVANCED ELECTRONIC CONTROL

- Precise temperature control
- Built-in diagnostics and operational information

#### CONDENSING DESIGN

- High efficiency operation with up to 0.90 Uniform Energy Factor to save money on operating costs

#### HELICAL INTERNAL HEAT EXCHANGER

- Spiral heat exchanger keeps hot combustion gases in the tank longer to lengthen the heat transfer cycle
- Positioned in the center of the tank for more even heat distribution
- Spiral design reduces the effect of lime scale and sediment on the heat exchanger to maintain high-efficiency operation over time

#### POWER VENT AND POWER DIRECT VENT WITH A SINGLE DESIGN

- Combined vertical and horizontal runs terminating through an outside wall. Vents using PVC, CPVC, or polypropylene pipe.
- 2” pipe vents up to 60 equivalent feet
- 3” pipe vents up to 150 equivalent feet

#### SIDE-MOUNTED HOT AND COLD RECIRCULATING TAPS

- Allows Vertex HV to be installed as part of combination space heating/water heating applications

#### AVAILABLE IN NATURAL GAS

### SIDE FIRED GAS BURNER

- Unique side fire design allows for optimal burner placement

### BLUE DIAMOND® GLASS COATING

- Provides superior corrosion resistance compared to industry standard glass lining.

### HEAVY-DUTY ANODIC PROTECTION

- Comes standard with dual sacrificial anodes to protect the tank
- Optional powered anode available for enhanced tank protection in all water conditions

### CSA CERTIFIED AND ASME RATED T&P RELIEF VALVE

### MAXIMUM HYDROSTATIC WORKING PRESSURE: 150 PSI

### CODE COMPLIANCE

- Meets NRCan and provincial thermal efficiency and standby loss requirements.

### DESIGN-CERTIFIED BY CSA

- Certified at 300 psi test pressure and 150 psi working pressure. Listed according to ANSI Z21.10.3 - CSA 4.3 standards governing storage tank-type water heaters.

### 6-YEAR LIMITED TANK AND PARTS WARRANTY

- For complete information, consult written warranty or go to [hotwater.com](http://hotwater.com)

\*Continuous hot water based on 65,000 BTU unit, 2.8 GPM continuous flow with a 65°F inlet water temperature, 110°F outlet temperature, and installed per the manufacturer’s instructions.



MODEL SHOWN GPCC-40L



# Commercial-Grade Residential Water Heaters

MODEL NUMBER	NORMAL CAPACITY	RATED STORAGE VOLUME	FIRST HOUR RATING	UEF	THERMAL EFFICIENCY	RECOVERY RATE AT 90°F TEMPERATURE RISE	INPUT	SHIPPING WEIGHT
	USG (L)	USG (L)	GPH (LPH)			GPH (LPH)	BTU/h	LB (KG)
GPC-40L	40 (151)	39 (147)	86 (325)	0.90	93%	62 (234)	50,000	216 (98.2)
GPC-50X	50 (189)	48 (181)	118 (446)	0.90	93%	81 (306)	65,000	246 (111.8)

Available in natural gas only.  
 Top Inlet and outlet connections: 3/4" male NPT. Circulation loop connections: 3/4" female NPT  
 Models certified for sea level to 10,100 ft. elevation.

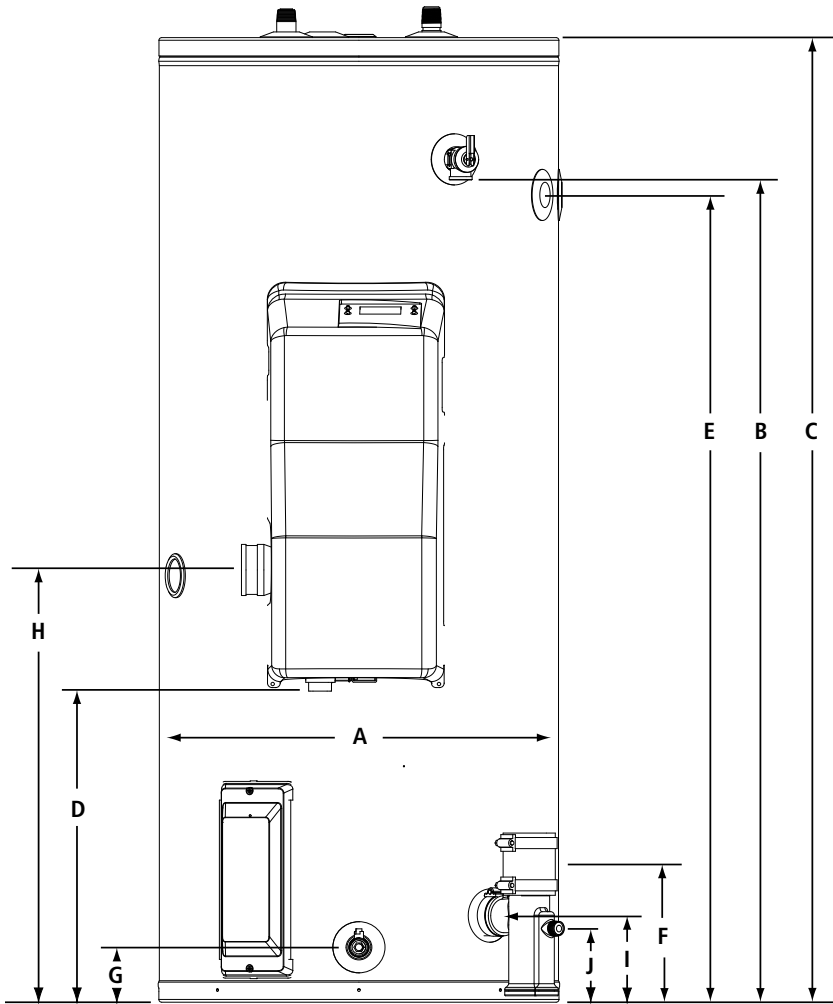

	DESCRIPTION	DIMENSIONS IN (CM)	
		40 GAL	50 GAL
A	DIAMETER	22 (56)	22 (56)
B	HEIGHT TO T&P	38-3/8 (97)	47-3/8 (120)
C	HEIGHT TO TOP	44-7/8 (114)	54-1/4 (138)
D	HEIGHT TO GAS CONNECTION	16-1/2 (42)	17-1/2 (44)
E	HEIGHT TO UPPER SIDE CONNECT	36-3/8 (92)	45-3/8 (115)
F	HEIGHT TO LOWER SIDE CONNECT	8-5/8 (22)	7-7/8 (20)
G	HEIGHT TO DRAIN VALVE	3-7/8 (10)	3 (8)
H	HEIGHT TO AIR INTAKE	22-1/8 (56)	24-1/4 (62)
I	HEIGHT TO EXHAUST	5-3/8 (14)	4-7/8 (12)
J	HEIGHT TO CONDENSATE CONNECTION	5-1/2 (14)	4 (10)
K	OVERALL DEPTH	28-1/2 (72)	28-1/2 (72)
L	WATER CONNECTIONS	8 (20)	8 (20)

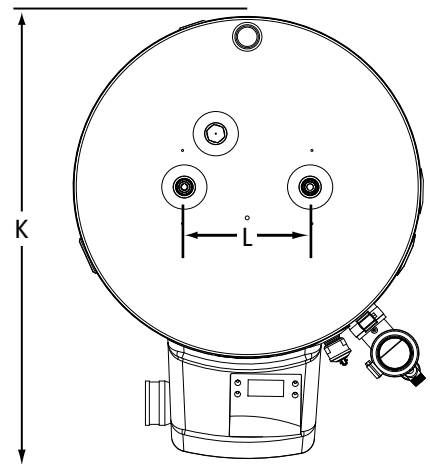

### OPTIONAL ACCESSORIES

PART NUMBER	DESCRIPTION
100112869	2" concentric termination kit
100111100	3" concentric termination kit
100187903	2" low-profile termination kit
100187887	3" low-profile termination kit
100112159	Condensate neutralizer kit
100305721	Powered anode kit

For Technical Information call 888-599-2837. A. O. Smith Enterprises Ltd. reserves the right to make product changes or improvements without prior notice.

# POLARIS

# Polaris™ High-Efficiency Residential Gas Water Heater

The Polaris high efficiency gas water heater is the high performance answer for today's hot water needs. It can provide endless hot water\* and can be used for a combination of domestic hot water and space heating.

### CONDENSING DESIGN

- Operates at up to 96% thermal efficiency which saves money on operating costs compared to a standard 80% efficient gas water heater
- Helical internal heat exchanger keeps hot combustion gases in the tank longer to transfer more heat into the water

### STAINLESS STEEL CONSTRUCTION

- Tank and helical heat exchanger are constructed from 444 stainless steel for excellent corrosion resistance without the need for an anode

### WHISPER QUIET OPERATION

- Ultra quiet blower and burner to minimize noise

### POWER DIRECT VENT DESIGN

- Direct vent using ULC S636, PVC, CPVC or Polypropylene (solid core only) through a sidewall or roof
- Optional concentric vent kit
- 2" pipe vents up to 52 equivalent feet (100-150k BTU/h inputs)
- 3" pipe vents up to 130 equivalent feet

### ADVANCED ELECTRONIC CONTROL

- Large touchscreen display
- Precise temperature control
- Advanced water heater status and diagnostics

### MODULATING GAS BURNER

- Modulating burner maintains high efficiency operation at lower input rates

### SIDE-MOUNTED HOT AND COLD RECIRCULATING TAPS

- Polaris can be easily installed with a recirculation system or as part of a combined domestic & space heating system

### FULLY SERVICEABLE FROM THE FRONT

- Two front access panels expose all serviceable components. Modular components are all easily removed

### AVAILABLE IN NATURAL GAS OR PROPANE

### CSA CERTIFIED AND ASME RATED T&P RELIEF VALVE

### 10-YEAR LIMITED TANK AND 1-YEAR PARTS WARRANTY

\*When sized appropriately. Model PR50-199 can deliver 6.95 GPM continuous flow, based on 65°F inlet water temperature, 120°F outlet temperature.



For Technical Information call 888-599-2837. A. O. Smith Enterprises Ltd. reserves the right to make product changes or improvements without prior notice.

POLR100 (01-23)

# POLARIS

## Polaris™ High-Efficiency Residential Gas Water Heater

### PERFORMANCE

Model	Series	Capacity		Maximum Certified Altitude	Input	Recovery Rate at 90°F Temperature Rise	Thermal Efficiency	Warranty Tank/Parts
		USG	L					
<b>NATURAL GAS</b>								
PR 34-100 N	200	34	129	7,700 (2,437)	100,000	129 (488)	96%	10/1
PR 34-130 N	200	34	129	7,700 (2,437)	130,000	168 (636)	96%	10/1
PR 34-150 N	200	34	129	7,700 (2,437)	150,000	190 (719)	94%	10/1
PR 50-130 N	200	50	189	7,700 (2,437)	130,000	165 (625)	95%	10/1
PR 50-150 N	200	50	189	7,700 (2,437)	150,000	190 (719)	95%	10/1
PR 50-175 N	200	50	189	7,700 (2,437)	175,000	222 (840)	96%	10/1
PR 50-199 N	200	50	189	7,700 (2,437)	199,000	253 (958)	96%	10/1

For propane models sub N with P. Natural gas models are series 200. Propane models are series 201. All models comply with national energy efficiency regulations. Input, output and recovery may vary depending upon air inlet and exhaust outlet installations, consult manual for details.

### DIMENSIONS & SHIPPING WEIGHT

Model	Height to Top of Tank	Tank Diameter	Height to Heating System Return	Height to Cold Water Inlet	Height to Heating System Outlet	Height to T&P	Height to Gas Supply	Height to Air Inlet	Water Connections	Gas Connections	Vent Diameter	Shipping Weight
	A IN (CM)	B IN (CM)	C IN (CM)	C IN (CM)	D IN (CM)	E IN (CM)	F IN (CM)	G IN (CM)	IN NPT	IN NPT	IN	LB (KG)
<b>NATURAL GAS</b>												
PR 34-100 N	48 ½ (123)	22 (56)	15 ¾ (40)	15 ¾ (40)	40 ½ (103)	41 (104)	6 ¾ (16)	6 ¾ (16)	1	½	2 or 3	150 (68)
PR 34-130 N	48 ½ (123)	22 (56)	15 ¾ (40)	15 ¾ (40)	40 ½ (103)	41 (104)	6 ¾ (16)	6 ¾ (16)	1	½	2 or 3	150 (68)
PR 34-150 N	48 ½ (123)	22 (56)	15 ¾ (40)	15 ¾ (40)	40 ½ (103)	41 (104)	6 ¾ (16)	6 ¾ (16)	1	½	2 or 3	150 (68)
PR 50-130 N	62 ¾ (158)	22 (56)	15 ¾ (40)	15 ¾ (40)	54 ½ (138)	55 (140)	6 ¾ (16)	6 ¾ (16)	1	½	2 or 3	176 (80)
PR 50-150 N	63 ¾ (162)	22 (56)	15 ¾ (40)	15 ¾ (40)	55 ¾ (142)	56 ¼ (143)	6 ¾ (16)	6 ¾ (16)	1	½	2 or 3	180 (82)
PR 50-175 N	63 ¾ (162)	22 (56)	15 ¾ (40)	15 ¾ (40)	55 ¾ (142)	56 ¼ (143)	6 ¾ (16)	6 ¾ (16)	1	½	3	180 (82)
PR 50-199 N	63 ¾ (162)	22 (56)	15 ¾ (40)	15 ¾ (40)	55 ¾ (142)	56 ¼ (143)	6 ¾ (16)	6 ¾ (16)	1	½	3	180 (82)

### OPTIONAL KITS

Description	Part Number
2" Concentric vent kit	100093946
3" Concentric vent kit	100093947

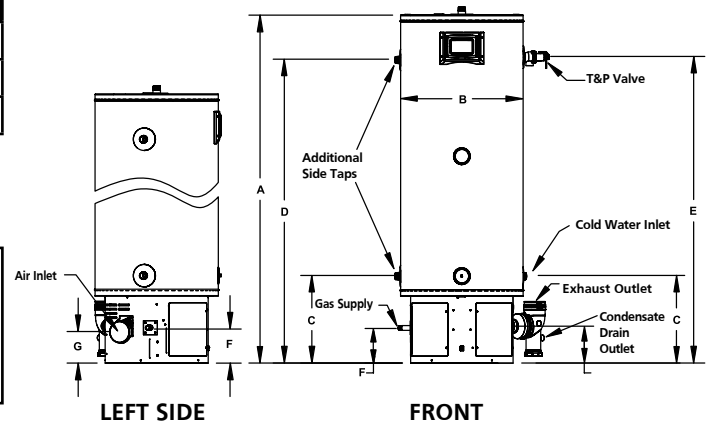
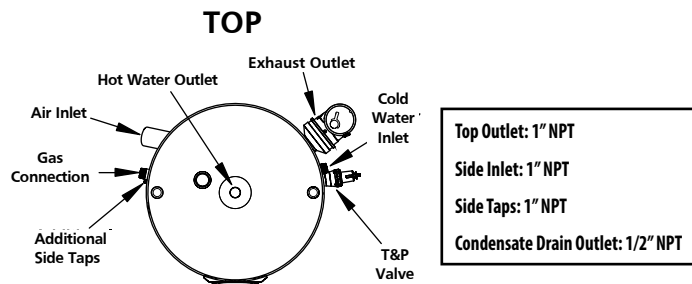

For Technical Information call 888-599-2837. A. O. Smith Enterprises Ltd. reserves the right to make product changes or improvements without prior notice.

**POLR100 (01-23)**

## Powered by **TAKAGI**

The A. O. Smith powered by Takagi condensing tankless water heaters provide endless hot water.\* The durable primary heat exchanger is made of commercial-grade copper while the secondary heat exchanger is made of Type 316L stainless steel, preventing corrosion and prolonging the life of the heater. These direct vent models combine durability and versatility in an easy-to-install space-saving design.



### **Features of Condensing Tankless Models:**

- Integrated temperature and error display
- Advanced safety features
- ULC S636 PVC, CPVC, polypropylene pipe or Cat. III/IV stainless steel venting
- Internal freeze protection system
- New 540P model with integrated recirculation pump

\*When sized appropriately



# Point of Use Electric Tankless Water Heaters

## EASY TO INSTALL

- Compact size for installations with space constraints
- Wall mount vertically or horizontally
- ¾" NPT water connections (1/2" NPT reducers included)

## DRY-FIRE PROTECTION

- Prevents element failure due to dry-fire
- Internal air bypass
- Temporary shutoff with excess air in chamber

## SCALE-REDUCTION TECHNOLOGY

- Reduces failures and service requirements due to scale build-up
- Power-sharing technology reduces scale deposits on elements
- Dupont™ Zytel® chambers resist scale buildup

## DIGITAL USER INTERFACE (2-CHAMBER MODEL)

- Easy temperature adjustment
- Error codes are clearly displayed

## WARRANTY

- 6-year limited chamber warranty
- 1-year limited parts warranty



SPECIFICATIONS												
Model	Series	Input		Amp Load	Recommended Breaker Size	Recommended Wire Gauge	Activation GPM	Flow Rate at 70°F Rise	Height	Depth	Width	Shipping Weight
		WATTS	VOLTS	AMP				GPM (LPM)	A IN (CM)	B IN (CM)	C IN (CM)	LB (KG)
<b>SINGLE CHAMBER, SINGLE ELEMENT MODELS</b>												
SSET-70E	100	7,000	240	29	40 Amp	8	0.25	0.7 (2.6)	15 ½ (39)	6 ½ (17)	7 (18)	9 (4)
SSET-90E	100	9,000	240	38	50 Amp	8	0.25	0.9 (3.4)	15 ½ (39)	6 ½ (17)	7 (18)	9 (4)
<b>TWO CHAMBER, TWO ELEMENT MODEL</b>												
SSET-180E	100	18,000	240	75	50 Amp x 2	8	0.25	1.8 (6.8)	16 ⅝ (42)	6 ½ (16)	11 ½ (29)	20 (9)

For Technical Information call 888-599-2837. A. O. Smith Enterprises Ltd. reserves the right to make product changes or improvements without prior notice.

## ADAPT™ PREMIUM CONDENSING TANKLESS WITH X3™ SCALE PREVENTION TECHNOLOGY & INTEGRATED RECIRC PUMP

Introducing A. O. Smith's ADAPT™ premium condensing gas tankless water heaters, delivering robust, on-demand performance and the flexibility to install in practically any residential setting.

### FEATURES:

#### X3™ SCALE PREVENTION TECHNOLOGY (PATENTED DESIGN)

- Units maintain like-new performance longer and life extended by up to 3x versus unprotected units
- Eliminates need for annual descaling
- Included with all X3 models, optional accessory for M (bypass) models

#### HEAVY-DUTY STAINLESS STEEL HEAT EXCHANGER DESIGN

- Single heavy-duty stainless steel heat exchanger design minimizes internal welds and improves overall reliability
- More resilient to scale buildup and corrosion

#### INTEGRATED RECIRCULATION PUMP & DISPLAY

- Integrated recirculation pump
- Built-in Control Display to set and review recirc schedules, status, and error codes

#### PERFORMANCE & EFFICIENCY

- 160,000, 180,000, 199,000 BTU/h models
- 9,000 BTU/h min. input
- 22:1 turndown ratio on 199,000 BTU/h models
- 10.5 GPM maximum flow rate
- 0.4 GPM activation flow rate
- 0.95 UEF, ENERGY STAR® certified
- Ultra Low NOx: NOx emissions less than 14 ng/J or 20 ppm for natural gas and less than 77 ppm for propane

#### ULTIMATE FLEXIBILITY EASE OF INSTALLATION

- Field convertible from natural gas to LP (kit included with unit)
- Vent up to 75' (23 m) with 2" pipe or up to 150' (46 m) with 3" pipe
- Cat. IV venting may be used
- Vent with ULC S636 certified PVC, CPVC, or polypropylene pipe
- X3 models include pressure relief valve
- Outdoor rated power cord standard on every unit
- Cascade up to 12 units (cable included with unit)

#### LIMITED WARRANTY

- No hard water exclusions on X3 models (exclusions apply to M models even with the addition of the optional X3 cartridge)
- 15-year limited warranty on heat exchanger in residential applications
- 5-year limited warranty on all parts in residential applications
- 1-year limited warranty on heat exchanger and parts in commercial applications



**ATHR-160X3, ATHR-180X3, ATHR-199X3**  
X3 Scale Prevention Technology included



**ATHR-160M, ATHR-180M, ATHR-199M**  
X3 Scale Prevention Technology can be added at any time (optional accessory)



CSA/ANSI Z21.10.3 • CSA 4.3





# Commercial-Grade Residential Gas Water Heaters

		ATHR-160M	ATHR-160X3	ATHR-180M	ATHR-180X3	ATHR-199M	ATHR-199X3
Installation Type		Indoor / Outdoor*		Indoor / Outdoor*		Indoor / Outdoor*	
X3™ Scale Prevention Technology		Optional Accessory	Included	Optional Accessory	Included	Optional Accessory	Integrated
Recirculation Pump		Integrated					
Input Rate	Minimum	9,000 BTU/h					
	Maximum	160,000 BTU/h		180,000 BTU/h		199,000 BTU/h	
Fuel Type		Natural Gas (Field Convertible to Liquid Propane, Kit Included)					
Heat Exchanger		Stainless Steel					
Uniform Energy Factor (UEF)		0.95					
Maximum Flow Rate**		10.5 GPM					
Activation Flow Rate		0.4 GPM					
Continuous Fire Flow Rate		0.26 GPM					
Water Pressure Min. - Max.		15 - 150 PSI (40 PSI Recommended for Maximum Flow)					
Supply Gas Pressure (NG)	Min. in W.C. (kPa)	3.5 (0.9)					
	Max. in W.C. (kPa)	10.5 (2.6)					
Supply Gas Pressure (LP)	Min. in W.C. (kPa)	8.0 (2)					
	Max. in W.C. (kPa)	13.0 (3.2)					
Hot/Cold Connections		3/4" NPT					
Gas Connection		1/2" NPT					
Temperature Settings Min. - Max.		100°F (38°C) - 140°F (60°C); Default 120°F (49°C)					
Ignition System		Electronic Ignition					
Power Supply		120V, 50Hz/60Hz, <5A					
Sound Level		50.3 dB**					
Elevation		Certified from Sea Level to 10,100' (3,078.5 m)					
Freeze Protection†		- 5°F (-21°C)					
Venting - Exhaust, Intake	Type	Power Direct Vent					
	Size, Max Run	2", 75' (5 cm, 22.9 m); 3", 150' (8 cm, 45.7 m)					
	Material	ULC S636 certified PVC, CPVC, or polypropylene					
Unit Dimensions	Height***	33.8" (86 cm)	44.6" (113 cm)	33.8" (86 cm)	44.6" (113 cm)	33.8" (86 cm)	44.6" (113 cm)
	Width	16.5" (42 cm)					
	Depth	16.1" (41 cm)					
	Weight	104 lb. (47 kg)					
Shipping Dimensions****	Height	20.8" (53 cm)					
	Width	22.3" (57 cm)					
	Depth	40" (102 cm)					
	Weight	125 lb (57 kg)					

All models are ENERGY STAR® certified.

\* Outdoor installations require outdoor vent cap kit (100369060) sold separately.

\*\* Based on factory settings.

\*\*\* Height from flue collar to top of X3 scale control media cartridge on X3 models and to top of manifold cartridge on M models.

\*\*\*\* Packaged and shipped on unit back.

† Internal freeze protection for heater only; Freeze protection for the X3 and bypass cartridges (kits sold separately) is recommended for outdoor installations.

Included with Heater: Manual, Pressure Relief Valve (X3 models only), Wall Mounting Bracket and Hardware, Vent Port Screws, Cascading Cable, Fuel Conversion Kit, Bird Screens

ARESS00523

## Commercial-Grade Residential Gas Water Heaters

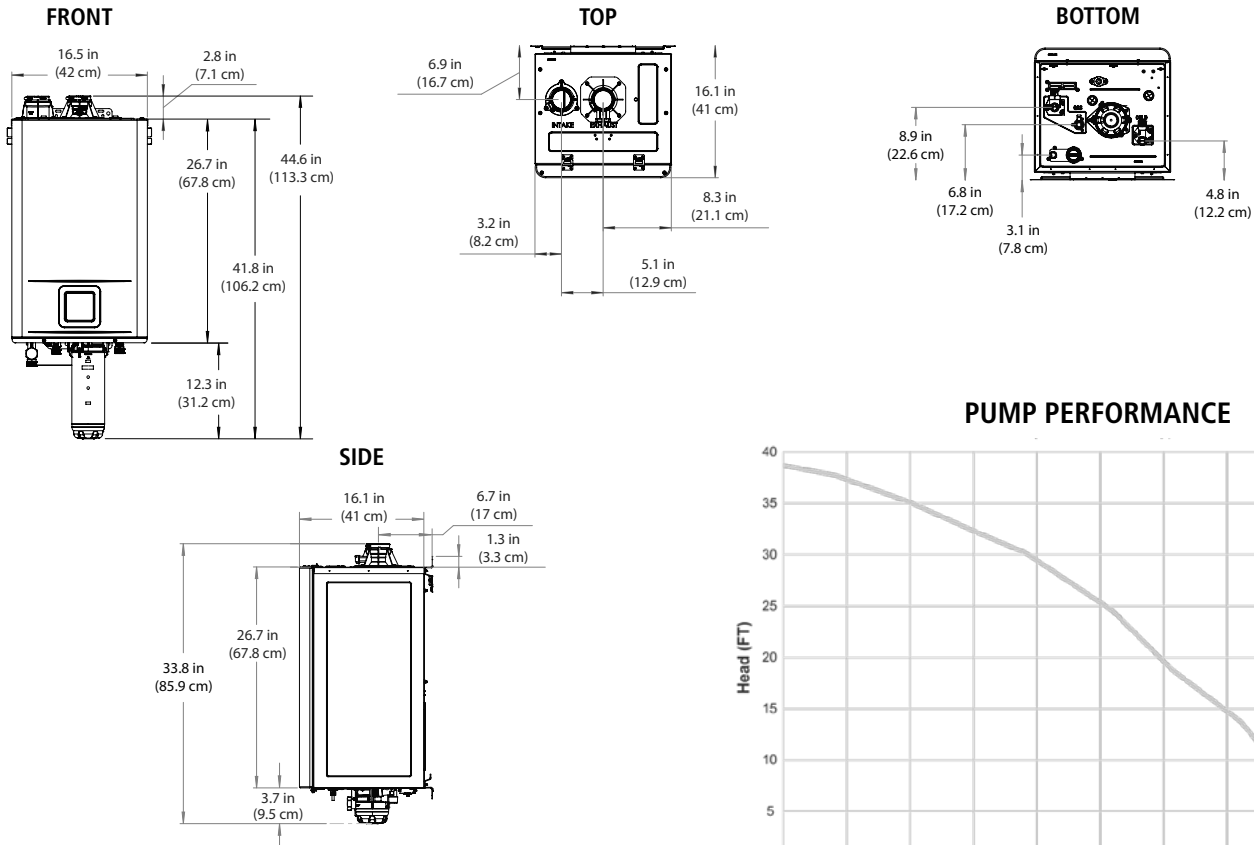

### PUMP PERFORMANCE

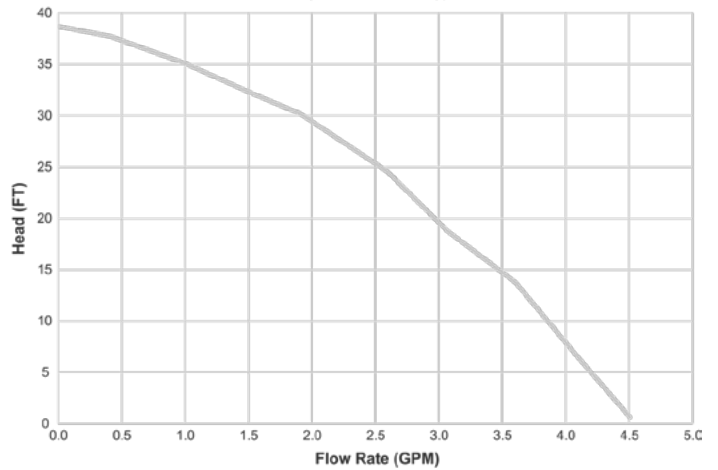



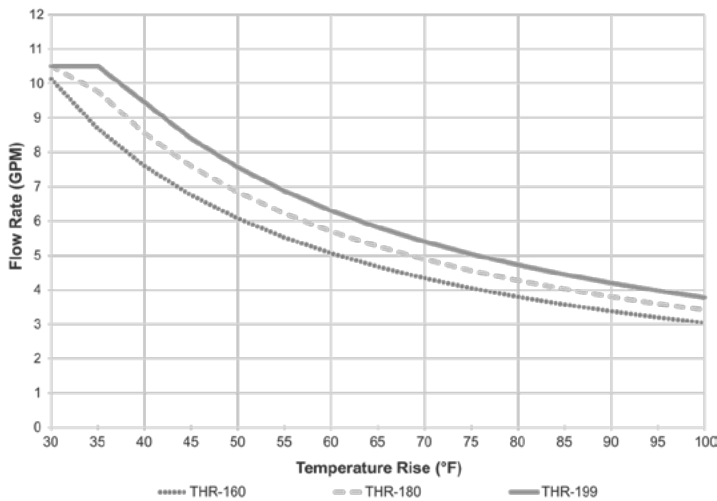



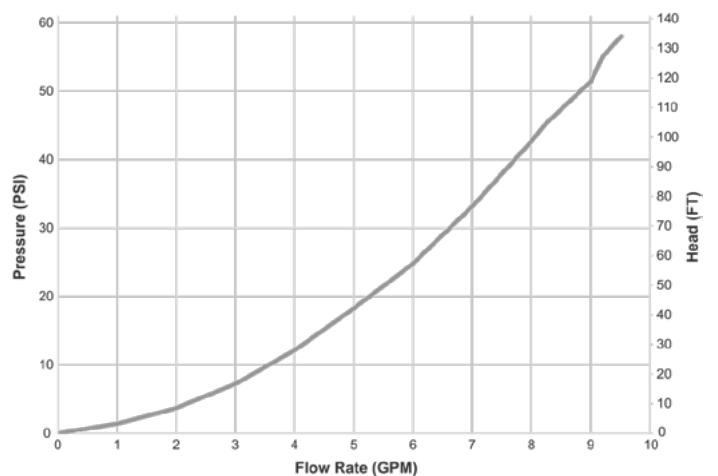

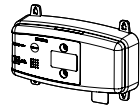
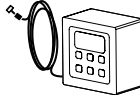
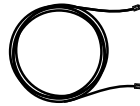
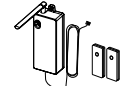
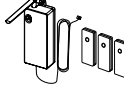
### FLOW RATE

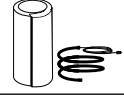

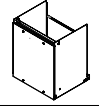
### PRESSURE LOSS

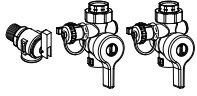

Item	Material Number		Description
X3 Cartridge	100368986		Add to an M model heater to prevent scale buildup and eliminate the need for annual descaling.
Wi-Fi Module Kit	100371922		Wi-Fi Module for electronically connecting tankless water heaters to the internet and adapter to connect to the water heater. Kit contains: Module (1x), Cable (1x), Adapter (1x)
Remote Temperature Controller	100371898		Remote Temperature Controller with 10' (3 m) cable.
Communication Cable - 10' (3 m)	100371889		Replacement 10' (3 m) Communication Cable for Remote Temperature Controller, WiFi Module, or On-Demand Receiver.
Communication Cable - 32' (10 m)	100371900		Extended 32' (10 m) Communication Cable for Remote Temperature Controller, WiFi Module, or On-Demand Receiver.
Remote Recirculation Kit - Two Buttons	100371920		Remote Recirculation Kit activates the water heater and recirculation at a touch of a button for on-demand hot water. Kit contains: Receiver (1x), Buttons (x2)
Remote Recirculation Kit - Three Buttons	100371921		Remote Recirculation Kit activates the water heater and recirculation at a touch of a button for on-demand hot water. Kit contains: Receiver (1x), Buttons (x3)
Individual Spare Button	100371913		Add Remote Recirculation Buttons to a system to a maximum of 30.
X3 Freeze Protection (X3 Models)	100325654		Freeze Protection for the X3 cartridge for outdoor installations. Cartridge is not protected by the water heater's internal freeze protection.
Bypass Freeze Protection (M Models)	100371918		Freeze Protection for the bypass cartridge for outdoor installations. Cartridge is not protected by the water heater's internal freeze protection.
Pipe Cover	100374697		Pipe Cover protects plumbing connections to the heater while improving the appearance of the installation. Affixes to bottom of heater.
Neutralizer Assembly Kit	100112159		Neutralizer Assembly neutralizes the condensate (acidic water) that forms in the heat exchanger of the water heater. It connects to the condensate drain port of the water heater by using connectors included with the neutralizer kit.
Outdoor Vent Cap Kit	100369060		Vent cap kit and accessories for installing the tankless heater outdoors. Kit contains: Vent Cap (1x), User Interface Overlay (1x)
Isolation Valve Kit with Pressure Relief Valve	100112156		Isolation Valves help control water flow during routine maintenance. Pressure Relief Valve limits pressure in the water heater. X3 models include a pressure relief valve.
Cross Over Valve Kit	100327167		For systems without a dedicated return line necessary. Install at the faucet furthest from the hot water heater.

For Technical Information, call 888-599-2837. A. O. Smith Enterprises Ltd. reserves the right to make product changes or improvements without prior notice.

## TANKLESS HIGH EFFICIENCY CONDENSING MODELS

### FEATURES

#### DESIGNED FOR PERFORMANCE

- Condensing technology provides UEF of up to 0.94
- Primary heat exchanger is constructed of commercial-grade copper which is more resilient against erosion
- Secondary heat exchanger is made of Type 316L Stainless Steel to protect against corrosion
- Continuous maximum flow rates up to 10.0 GPM
- Available in natural gas (NG) or propane (LP)
- Electronic ignition - no pilot light
- Includes a built-in temperature controller and advanced diagnostics for easy troubleshooting
- Factory-installed power cord
- New 540P model with integrated recirculation pump
- Easy-Link up to 4 units with no additional parts or accessories needed using built-in Easy-Link System (540 models only)
- Multi-link up to 20 units (540 models only) with a multi-unit controller
- Internal freeze protection system

#### SAFETY FEATURES

- Air-Fuel Ratio (AFR) Sensor
- Exhaust & water temperature safety control
- Overheat cut-off fuse

#### POWER DIRECT VENT DESIGN

- Exhaust, 3" venting up to 70 equivalent feet or 4" venting up to 100 equivalent feet
- Provides flexible venting with ULC S636 approved PVC, CPVC or polypropylene pipe for intake and exhaust (solid core only)
- Category III/IV Stainless Steel venting can also be used

#### WARRANTY

- 15-year limited warranty on heat exchanger in residential applications
- 5-year limited warranty on heat exchanger in commercial applications
- 5-year limited warranty on all parts



**ATI-240H**  
**ATI-340H**



**ATI-540P**



540H model only

ANSI Z21.10.3 CSA 4.3

## FLOW RATE vs TEMPERATURE RISE

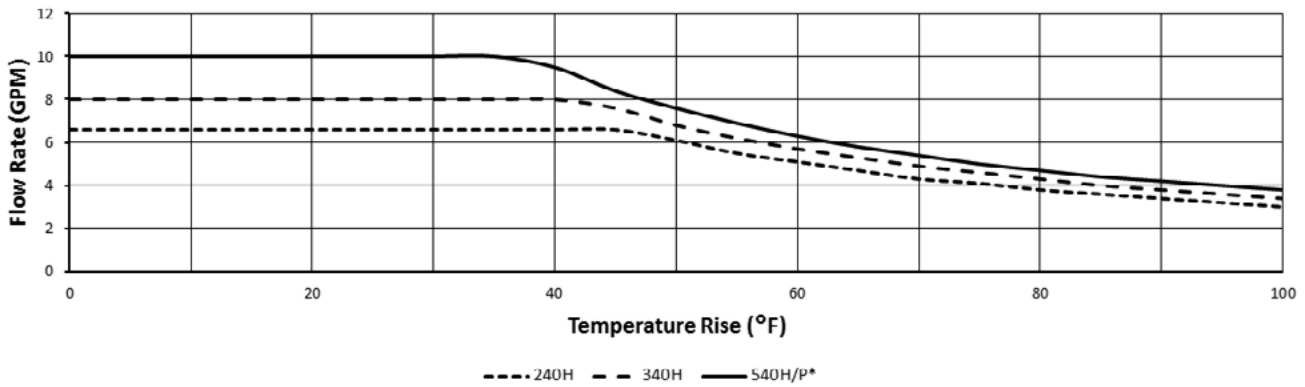

\*Maximum flow rate with set temperature above 130°F (55°C) is 8.0 GPM.

## PRESSURE LOSS vs FLOW RATE

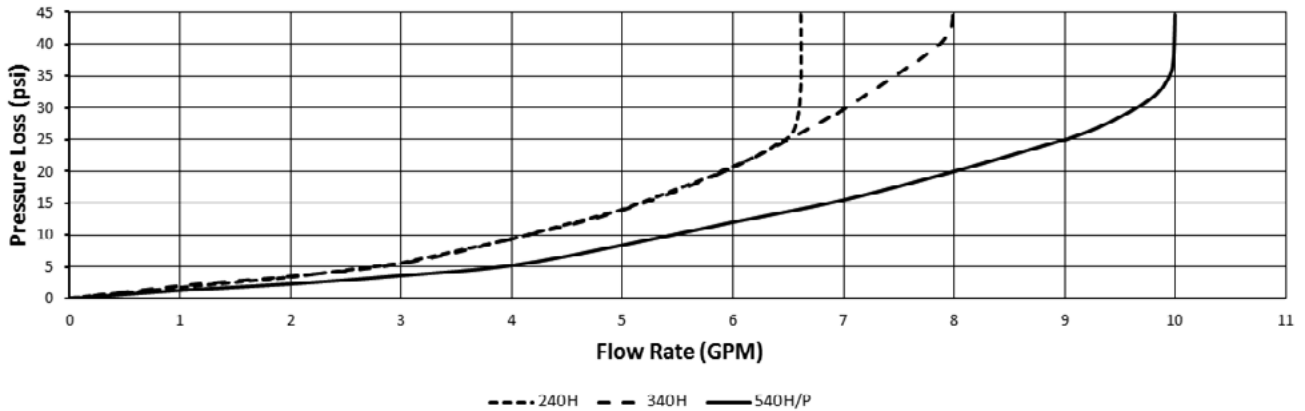

## Optional Accessories

PART NUMBER	DESCRIPTION
100112163	Concentric termination kit
100112159	Condensate neutralizer kit
100209924	Remote temperature controller for temperatures up to 167°F (240H/340H/540H models only)
100112572	Remote temperature controller for temperatures up to 185°F (540H models only)
100276687	Remote temperature controller for temperatures up to 140°F (540P only)
100112691	Multi-unit controller (540H/P models only)
100112156	Isolation valve kit (with Pressure Relief Valve)
100112718	Pipe cover
100113154	Product Preservers® Anti-Scale System
100113130	Non-return valve for Common Vent Systems

### SAMPLE SPECIFICATION

Water heater(s) shall be A. O. Smith tankless water heater model \_\_\_\_\_, having a maximum input rating of \_\_\_\_\_ BTU/h. The heater shall have ¾" male NPT water and gas connections. The inlet gas supply pressures shall be \_\_\_\_\_ in. WC (minimum) up to \_\_\_\_\_ in. WC (maximum) for \_\_\_\_\_ fuel. The heater(s) shall incorporate an integrated temperature controller that will provide heater set temperature, diagnostic, and fault history information.

The water heater(s) shall be vented with 3" or 4" ULc S636 approved Schedule 40 PVC or CPVC, polypropylene, or Category IV vent pipe with a length not to exceed 70' (equivalent) for 3" vent or 100' (equivalent) for 4" vent, terminating horizontally or vertically. The intake air pipe may be of such material as PVC or CPVC, ABS, polypropylene, aluminum, or Category IV pipe and cannot exceed 70' (equivalent) for 3" pipe or 100' for 4" pipe.

The water heater(s) shall use a commercial grade copper alloy, fin tube primary heat exchanger with quick release brass or bronze waterways, and a 316L stainless steel secondary heat exchanger. The heater(s) shall be controlled by an onboard solid-state printed circuit board using thermistors to monitor inlet and outlet water temperature and exhaust temperature, a flow sensor to measure flow rate, a flame sensor to monitor combustion, and an air-fuel ratio rod to measure and adjust operation in order to maintain optimal combustion efficiency. The heater(s) shall also consist of inline fusing and surge absorbers for electrical surge protection, an electronic spark igniter, aluminized stainless steel burners, hi-limit temperature switch to monitor water temperature, modulating gas valve, and an overheat cutoff fuse. The heater(s) shall include an exhaust temperature monitoring system using an exhaust thermistor and automatic hi-limit switch to maintain safe exhaust temperatures for Schedule 40 PVC and incorporate ceramic heating blocks and an auto-fire system for freeze protection of the heat exchanger and water piping.

The water heater(s) shall be design certified by CSA according to ANSI Z21.10.3 · CSA 4.3 and meet the energy efficiency requirements of NRCan and the current edition of ASHRAE 90.1.

MODEL	FUEL TYPE	GAS CONSUMPTION INPUT		INLET GAS PRESSURE		UEF	MAX GPM*	HOT/COLD AND GAS CONN.	DIMENSIONS IN (CM)			UNIT WEIGHT LB (KG)
		MIN. BTU/h	MAX. BTU/h	MIN. W.C.	MAX. W.C.				HEIGHT A	WIDTH B	DEPTH C	
ATI-240H-N	Natural	15,000	160,000	5.0	10.5	0.94	6.6	¾" NPT	23 ⅝ (60)	17 ¾ (45)	11 ¼ (29)	71 (32)
ATI-240H-P	Propane	13,000	160,000	8.0	14.0	0.94	6.6	¾" NPT	23 ⅝ (60)	17 ¾ (45)	11 ¼ (29)	71 (32)
ATI-340H-N	Natural	15,000	180,000	5.0	10.5	0.94	8.0	¾" NPT	23 ⅝ (60)	17 ¾ (45)	11 ¼ (29)	71 (32)
ATI-340H-P	Propane	13,000	180,000	8.0	14.0	0.94	8.0	¾" NPT	23 ⅝ (60)	17 ¾ (45)	11 ¼ (29)	71 (32)
ATI-540H-N	Natural	15,000	199,000	5.0	10.5	0.93	10.0	¾" NPT	23 ⅝ (60)	17 ¾ (45)	11 ¼ (29)	71 (32)
ATI-540H-P	Propane	13,000	199,000	8.0	14.0	0.93	10.0	¾" NPT	23 ⅝ (60)	17 ¾ (45)	11 ¼ (29)	71 (32)
ATI-540P-N	Natural	15,000	199,000	4.0	10.5	0.93	10.0	¾" NPT	23 ⅝ (60)	17 ¾ (45)	11 ¼ (29)	71 (32)
ATI-540P-P	Propane	13,000	199,000	8.0	14.0	0.93	10.0	¾" NPT	23 ⅝ (60)	17 ¾ (45)	11 ¼ (29)	71 (32)

15-150 psi Water Pressure. 40 psi or above is recommended for maximum flow.

\*Current numbers based on factory testing; 0.4 GPM required for continuous fire after initial ignition.

Models are certified from sea level to 10,100 ft. (3,078 m) elevations.

The manufacturer reserves the right to discontinue, or change at any time, specifications or designs without notice and without incurring obligation.

### ATI-240H, ATI-340H and ATI-540 H/P DIMENSIONS

**MINIMUM CLEARANCES: TOP 12", BOTTOM 12", FRONT\* 4", BACK 1", SIDES 3"**  
 \*Recommended 24" clearance from front of unit for maintenance

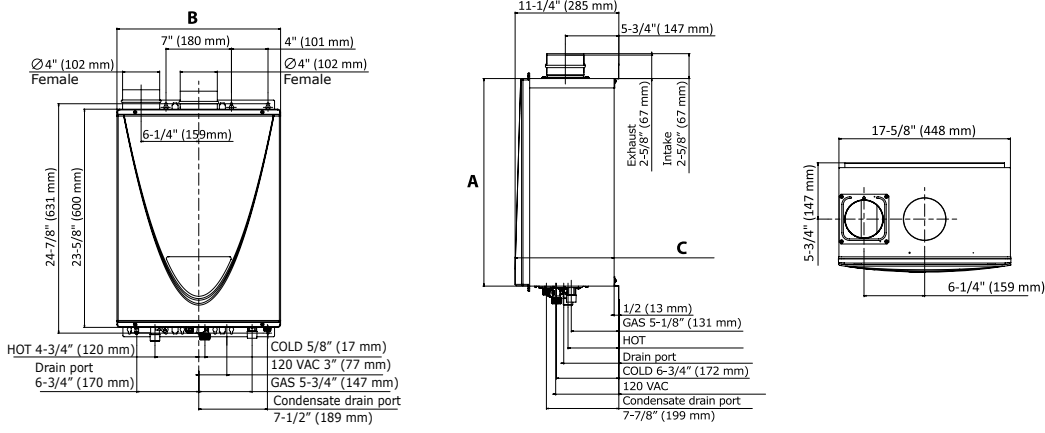

**Bottom View 240H, 340H, and 540H**

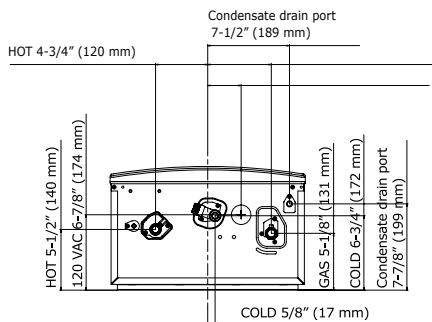

**Bottom View 540P**

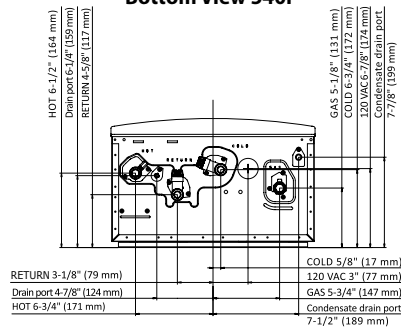

For Technical Information call 888-599-2837. A. O. Smith Enterprises Ltd. reserves the right to make product changes or improvements without prior notice.

# Appendices

## Reference Calculations and Conversions for Electricity

### Ohm's Law

Ohm's Law defines the relationships between (P) power, (E) voltage, (I) current, and (R) resistance. One ohm is the resistance value through which one volt will maintain a current of one ampere.

(I) Current is what flows on a wire or conductor like water flowing down a river. Current flows from points of high voltage to points of low voltage on the surface of a conductor. Current is measured in (A) amperes or amps.

(E) Voltage is the difference in electrical potential between two points in a circuit. It's the push or pressure behind current flow through a circuit, and is measured in (V) volts.

(R) Resistance determines how much current will flow through a component. Resistors are used to control voltage and current levels. A very high resistance allows a small amount of current to flow. A very low resistance allows a large amount of current to flow. Resistance is measured in ohms.

(P) Power is the amount of current times the voltage level at a given point measured in wattage or watts.

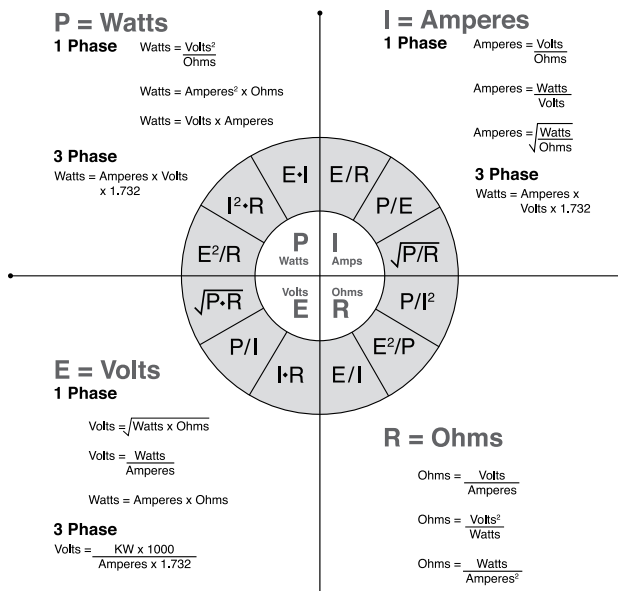

## Reference Guide for Water Heating

One US gallon of fresh water weighs 8.333 lb.

Water expands 4.34% heated from 40° to 212° F.

1 BTU = Amount of heat required to raise the temperature of 1 lb. of water 1° F.

$$\text{Recovery GPH (Electric)} = \frac{\text{KW} \times 3412}{8.33 \times \Delta T}$$

$$\text{Recovery GPH (Gas)} = \frac{\text{Input} \times \text{Efficiency}}{8.33 \times \Delta T}$$

$$\text{Req. BTU Input} = \frac{\text{Water Heater Capacity} \times 8.33 \times \Delta T}{\% \text{ Efficiency}}$$

First Hour Draw (FHD)

$$\text{FHD} = (\text{Storage} \times \% \text{ Efficiency}) + \text{Recovery}$$

% of hot and cold water needed to be mixed to obtain a desired temperature

$$\text{Hot water percentage} = \frac{M-C}{H-C}$$

$$\text{Cold water percentage} = \frac{H-M}{H-C}$$

Water C = Cold Water Temperature  
H = Hot Water Temperature  
M = Mixed Water Temperature

$$\% \text{ Efficiency} = \frac{\text{GPH} \times 8.33 \times \text{Temp. Rise}}{\text{BTU/Hr. Input}}$$



# Appendices

## Reference Guide for Water Heating

$$\text{BTU/Output} = \text{GPH} \times 8.33 \text{ lbs./Gal.} \times \text{Temp. Rise}$$

$$\text{BTU/Input} = \frac{\text{GPH} \times 8.33 \times \text{Temp. Rise}}{\% \text{ Efficiency}}$$

$$\text{KW} = \frac{\text{GPH} \times 8.33 \times \text{Temp. Rise}}{3413}$$

### Temperatures

To convert from degrees Centigrade (C) to degrees Fahrenheit (F) multiply the number of degrees C by 9/5 (or 1.8) and add 32.

To convert from degrees Fahrenheit (F) to degrees Centigrade (C) first subtract 32 from the number of degrees F then multiply the remainder by 5/9 (or 0.556).

### Gas

Gas	BTU
1 lb. of Butane	= 21,300
1 Gal. of Butane	= 102,600
1 Cu. Ft. of Butane	= 3,260
1 Cu. Ft. of Manufactured	= 530
1 Cu. Ft. of Mixed	= 850
1 Cu. Ft. of Natural	= 1,075
1 lb. of Propane	= 21,600
1 Gal. of Propane	= 91,700
1 Cu. Ft. of Propane	= 2,570

### Oil vs. Electric vs. Propane vs. Natural Gas

Oil 1 litre = 36,515 BTUs\*  
Example Price = 60.0¢/litre

Electric 1 Kilowatt Hour = 3,413 BTUs\*  
Example Price = 10.1¢/KW (kilowatt)

Propane 1 litre = 24,197 BTUs\*  
Example Price = 63.0¢/litre

Natural Gas 1 M<sup>3</sup> 35,310 BTUs\*  
Example Price = 44.0¢/M<sup>3</sup> (cubic metre)\*\*

Formula  $\frac{\text{BTUs per Unit} \times \text{Efficiency}}{\text{Cost per Unit}}$

Example: Propane =  $\frac{24,197 \times 92\%}{0.63} = 35335$  BTUs per \$1.00

GST is extra on all prices.

\* Information supplied by The Ontario Ministry of Energy.

\*\* This price reflects delivery charge and monthly administration charge to service your account.

### Formulas and Facts

- 1 gallon of water weighs 8.33 lbs.
- 1 gallon of water has a volume of 231 cubic inches
- 1 cubic foot of water weighs 62.38 lbs. and contains 7.48 gallons of water
- 100 feet of 3/4" copper pipe contains 2.5 gallons of water; 1" pipe contains 4.3 gallons
- 8.33 BTU will raise 1 gallon of water 1° F at 100% efficiency (electricity)

# Appendices

## Reference Guide for Water Heating

- 11 BTUs are required to raise 1 gallon of water 1° F at 70% efficiency (gas)
- 3,412 BTUs equal 1 kilowatt hour (KW)
- 1 KW will raise 410 gallons of water 1° F at 100% efficiency
- 1 BTU x 0.293 = watts
- 1 KW = 1000 watts
- 2.42 watts are required to raise 1 gallon of water 1° F
  - 1 KW will raise 10.25 gallons of water 40° F at 100% efficiency
  - 1 KW will raise 6.8 gallons of water 60° F at 100% efficiency
  - 1 KW will raise 5.1 gallons of water 80° F at 100% efficiency
  - 1 KW will raise 4.1 gallons of water 100° F at 100% efficiency

### Formula for mixing hot water

$$\frac{M-C}{H-C} = \text{Percent of hot water required to produce desired mixed temperature}$$

Where:

M = mixed water temperature;

C = cold water temperature;

H = hot water temperature

For example: How much of a shower is hot water and how much is cold water?

My shower temperature is 105° F, my water heater thermostat is set on 120° F and the cold water inlet temperature is 50° F.

$$\frac{105 - 50 = 55}{120 - 50 = 70} = 79\% \text{ of the shower is } 120^\circ \text{ hot water}$$

This formula for mixing hot water is important when explaining a NOT ENOUGH HOT WATER trouble call and the water heater is functioning properly.

ELECTRIC	GAS
<b>ENERGY COSTS:</b>	<b>ENERGY COSTS:</b>
KW x fuel costs = energy costs	Cubic feet x fuel costs = energy costs
100 x 0.05 = \$5.00	100 x 0.75 = \$7.50
To obtain gallons per hour (GPH) recovery <u>WATTS</u> 2.42 x (temp rise ° F)	To obtain gallons per hour (GPH) recovery <u>HOURLY INPUT (BTUs)</u> 11.0 x (temp rise ° F)
I have a 30-gallon electric heater, non-simultaneous operation, 4,500 watt elements. What is the recovery GPH if my cold water is 40° F and my thermostat is set to 120° F? <u>4,500</u> 2.42 x 80 per hour = 23 gallons	I have a 30-gallon gas heater, rated at 40,000 BTUs. What is the recovery GPH if my cold water is 40° F and my thermostat is set to 120° F? <u>40,000</u> 11.0 x 80 per hour = 45 gallons
Temperature Rise (° F) <u>WATTS</u> 2.42 x GPH	Temperature Rise (° F) <u>HOURLY INPUT (BTUs)</u> 11.0 x GPH
I have a 30-gallon electric heater, non-simultaneous operation, 4,500 watt elements. What is the maximum temperature rise if the heater can recover 23 gallons per hour? <u>4,500</u> 2.42 x 23 rise = 80° temp	I have a 30-gallon gas heater, rated at 40,000 BTUs. What is the maximum temperature rise if the heater can recover 45 gallons per hour? <u>40,000</u> 11.0 x 45 rise = 80° temp

## Reference Guide for Water Heating

Oil	BTU
1 Gal. #1 Fuel	= 136,000
1 Gal. #2 Fuel	= 138,500
1 Gal. #3 Fuel	= 141,000
1 Gal. #5 Fuel	= 148,500
1 Gal. #6 Fuel	= 152,000

1 lb. of Gas = 28" Water Column

1 lb. of Gas = 16 oz.

100 Cu. Ft. = 1 therm.

### Conversions

Multiply	By	To Obtain
BTU/HR	0.293	W
Ft.	0.3048	m
Ft./min., fpm	0.00508	m/s
Ft. <sup>2</sup>	0.0929	m <sup>2</sup>
Ft. <sup>3</sup>	0.0283	m <sup>3</sup>
Gallon (U.S. 231 in <sup>3</sup> )	3.79	L
Gallon	0.00379	m <sup>3</sup>
Horsepower (boiler)	9.81	KW
Inch	25.4	mm
Mile	1.61	km
Pound lb. (mass)	0.454	kg
Psi	6.89	kPa