

Instruction Manual COMMERCIAL GAS WATER HEATER

MODELS (A/S/M) TX-199
SERIES 100 & 101
INSTALLATION - OPERATION -
SERVICE - MAINTENANCE



ANSI/NSF 5



WARNING: If the information in these instructions is not followed exactly, a fire or explosion may result causing property damage, personal injury or death.

- Do not store or use gasoline or other flammable vapors and liquids in the vicinity of this or any other appliance.
- **WHAT TO DO IF YOU SMELL GAS:**
 - Do not try to light any appliance.
 - Do not touch any electrical switch; do not use any phone in your building.
 - Immediately call your gas supplier from a neighbor's phone. Follow the gas supplier's instructions.
 - If you cannot reach your gas supplier, call the fire department.
- Installation and service must be performed by a qualified installer, service agency or the gas supplier.

Thank you for buying this energy efficient water heater. We appreciate your confidence in our products.

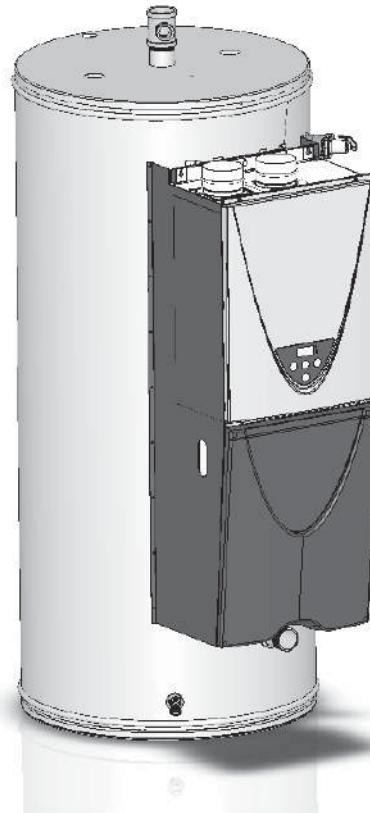

⚠ WARNING



Read and understand this instruction manual and the safety messages herein before installing, operating or servicing this water heater.

Failure to follow these instructions and safety messages could result in death or serious injury.

This manual must remain with the water heater.

• For Your Safety •

AN ODORANT IS ADDED TO THE GAS USED BY THIS WATER HEATER.

KEEP THIS MANUAL IN THE POCKET ON HEATER FOR FUTURE REFERENCE
WHenever MAINTENANCE ADJUSTMENT OR SERVICE IS REQUIRED.

TABLE OF CONTENTS





GENERAL SAFETY INFORMATION.....	4	WATER HEATER INSTALLATION.....	37
Precautions	4	Water Heating Unit Condensate Drain	37
Grounding Instructions	4	Supply Gas Line Installation.....	39
Hydrogen Gas Flammable	4	Measuring Inlet Gas Pressure.....	42
INTRODUCTION	6	Supply Gas Pressure Adjustment	42
Abbreviations Used	6	Gas Line Connection.....	43
Qualifications.....	6	Gas Line Leak Testing.....	43
Preparing for the Installation	6	Purging.....	43
FEATURES AND COMPONENTS	7	Electrical Connections.....	43
Basic Operation.....	7	Water Line Connections	44
INSTALLATION CONSIDERATIONS	10	T&P Valve Discharge Pipe	44
Rough-In Dimensions.....	10	TEMPERATURE REGULATION	46
Locating the Water Heater	11	High Temperature Limit Control (ECO)	46
Vent Piping Options.....	12	Thermostat Control	46
Hard Water	12	Firing Rate Modulation	46
Circulation Pumps	12	High Temperature Applications	46
INSTALLATION REQUIREMENTS	13	CONTROL SYSTEM OPERATION	47
Gas Supply Pressure Requirements.....	13	Temperature Remote Controller	47
Supply Gas Regulator	14	START UP	49
Power Supply	14	Prior to Start up	49
Mixing Valves	14	Initial Operation	49
Dish-washing Machines	15	Flow Rates	49
Closed Water Systems.....	15	Lighting the Water Heater	50
Thermal Expansion	15	Normal Operation.....	52
Safety Valve Requirements	16	Setting the Outlet Water Temperature.....	52
Condensate Drain	17	Default Outlet Temperature	53
Combustible Material Storage.....	17	Setting Units of Measure.....	53
Ventilation Requirements	18	Freeze Protection System.....	53
Direct Vent Installations.....	22	TROUBLESHOOTING	54
Single-Vent Installations.....	23	Installation Checklist	54
Stainless Steel Vent Installations	24	Operational Problems	54
Common Direct Venting Requirements.....	26	Replacement Parts.....	56
Common Direct-Venting System	26	General Fault and Alert Conditions	56
Concentric Termination Installation Preparation.....	28	Troubleshooting Chart.....	57
Air Requirements	30	Error Codes.....	58
INSTALLATION REQUIREMENTS - COMMONWEALTH OF MASSACHUSETTS.....	32	Water Heating Unit Controller Fault and Alert Conditions.....	59
Installing Carbon Monoxide Detectors	32	MAINTENANCE	61
Approved Carbon Monoxide Detectors	32	General	61
Signage	32	Precautions	61
Inspection.....	32	Water heating unit Maintenance and Service.....	61
Exemptions	32	Drain Valve.....	63
Manufacturer Requirements - Gas Equipment Venting System Provided	32	Vent System Maintenance	63
Manufacturer Requirements - Gas Equipment Venting System Not Provided	32	DIAGRAMS	64
HIGH-ALTITUDE INSTALLATIONS.....	33	Wiring Diagram	64
Termination Clearances for Sidewall Installations.....	34	Circulation Pump Wiring Diagrams	65
Clearances For Rooftop Terminations.....	36	Water Piping Diagrams	66

SAFE INSTALLATION, USE, AND SERVICE

The proper installation, use, and servicing of this water heater is extremely important to your safety and the safety of others.

Many safety-related messages and instructions have been provided in this manual and on your own water heater to warn you and others of a potential injury hazard. Read and obey all safety messages and instructions throughout this manual. It is very important that the meaning of each safety message is understood by you and others who install, use, or service this water heater.

	This is the safety alert symbol. It is used to alert you to potential personal injury hazards. Obey all safety messages that follow this symbol to avoid possible injury or death.
---	--

	DANGER indicates an imminently hazardous situation which, if not avoided, will result in injury or death.
	WARNING indicates a potentially hazardous situation which, if not avoided, could result in injury or death.
	CAUTION indicates a potentially hazardous situation which, if not avoided, could result in minor or moderate injury.
	CAUTION used without the safety alert symbol indicates a potentially hazardous situation which, if not avoided, could result in property damage.

All safety messages will generally tell you about the type of hazard, what can happen if you do not follow the safety message, and how to avoid the risk of injury.

APPROVALS



GENERAL SAFETY INFORMATION

PRECAUTIONS

DO NOT USE THIS WATER HEATER IF ANY PART HAS BEEN EXPOSED TO FLOODING OR WATER DAMAGE. Immediately call a qualified service agency to inspect the water heater and to make a determination on what steps should be taken next.

If the unit is exposed to the following, do not operate heater until all corrective steps have been made by a qualified service agency.

1. External fire.
2. Damage.
3. Firing without water.

GROUNDING INSTRUCTIONS

This water heater must be grounded in accordance with the **National Electrical Code** and/or local codes. These codes must be followed in all cases. Failure to ground this water heater properly may also cause erratic control system operation.

This water heater must be connected to a grounded metal, permanent wiring system; or an equipment grounding conductor must be run with the circuit conductors and connected to the equipment grounding terminal or lead on the water heater.

HYDROGEN GAS FLAMMABLE

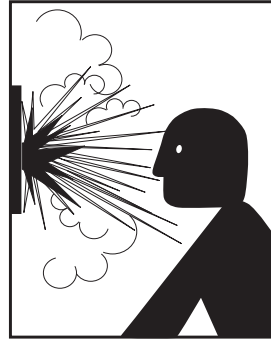

! WARNING

Explosion Hazard

- Flammable hydrogen gases may be present.
- Keep all ignition sources away from faucet when turning on hot water.

Hydrogen gas can be produced in a hot water system served by this water heater that has not been used for a long period of time (generally two weeks or more). Hydrogen gas is extremely flammable. To reduce the risk of injury under these conditions, it is recommended that a hot water faucet served by this water heater be opened for several minutes before using any electrical appliance connected to the hot water system. If hydrogen is present there will probably be an unusual sound such as air escaping through the pipe as the water begins to flow. **THERE SHOULD BE NO SMOKING OR OPEN FLAME NEAR THE FAUCET AT THE TIME IT IS OPEN.**

Verify the power to the water heater is turned off before performing any service procedures. The Enable /Disable switch on front panel disables the 24-volt gas valve. Electrical supply must be turned off at circuit breaker serving water heater.



! WARNING

Read and understand this instruction manual and the safety messages herein before installing, operating or servicing this water heater.

Failure to follow these instructions and safety messages could result in death or serious injury.

This manual must remain with the water heater.

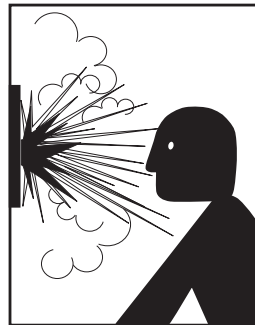

! WARNING

Explosion Hazard

- Overheated water can cause water tank explosion.
- Properly sized temperature and pressure relief valve must be installed in the opening provided.

! DANGER

Water temperature over 125°F (52°C) can cause severe burns instantly resulting in severe injury or death.

Children, the elderly and the physically or mentally disabled are at highest risk for scald injury.

Feel water before bathing or showering.

Temperature limiting devices such as mixing valves must be installed when required by codes and to ensure safe temperatures at fixtures.

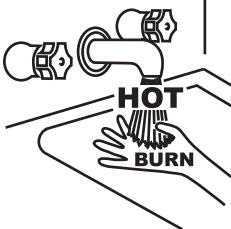



CAUTION

Improper installation, use and service may result in property damage.

- Do not operate water heater if exposed to flooding or water damage.
- Inspect anode rods regularly, replace if damaged.
- Install in location with drainage.
- Fill tank with water before operation.
- Properly sized thermal expansion tanks are required on all closed water systems.

Refer to this manual for installation and service.

⚠ WARNING	
Fire or Explosion Hazard	
<ul style="list-style-type: none"> • Do not store or use gasoline or other flammable vapors and liquids in the vicinity of this or any other appliance. • Avoid all ignition sources if you smell gas. • Do not expose water heater controls to excessive gas pressure. • Use only the gas shown on the water heater rating label. • Maintain required clearances to combustibles. • Keep ignition sources away from faucets after extended periods of non-use. 	
	<p>Read instruction manual before installing, using or servicing water heater.</p> 

⚠ WARNING	
Fire Hazard	
	<p>For continued protection against risk of fire:</p> <ul style="list-style-type: none"> • Do not install water heater on carpeted floor. • Do not operate water heater if exposed to flooding or water damage.



⚠ WARNING	
Breathing Hazard - Carbon Monoxide Gas	
	<ul style="list-style-type: none"> • Do not obstruct water heater air intake with insulating blanket. • Gas and carbon monoxide detectors are available. • Install water heater in accordance with the instruction manual.
<p>Breathing carbon monoxide can cause brain damage or death. Always read and understand instruction manual.</p>	

⚠ WARNING	
Fire and Explosion Hazard	
	<ul style="list-style-type: none"> • Use joint compound or Teflon tape compatible with propane gas. • Leak test gas connections before placing water heater in operation. • Disconnect gas piping at main gas shutoff valve before leak testing heater. • Install sediment trap in accordance with NFPA 54 or CAN/CSA B149.1.

CAUTION	
Property Damage Hazard	
<ul style="list-style-type: none"> • All water heaters eventually leak. • Do not install without adequate drainage. 	

⚠ WARNING	
Fire and Explosion Hazard	
	<ul style="list-style-type: none"> • Do not use water heater with any gas other than the gas shown on the rating label. • Excessive gas pressure to gas valve can cause serious injury or death. • Turn off gas lines during installation. • Contact a qualified installer or service agency for installation and service.

⚠ WARNING	
Electrical Shock Hazard	
	<ul style="list-style-type: none"> • Turn off power at the branch circuit breaker serving the water heater before performing any service. • Label all wires prior to disconnecting when performing service. Wiring errors can cause improper and dangerous operation. • Verify proper operation after servicing. • Failure to follow these instructions can result in personal injury or death.

⚠ WARNING	
Jumping out control circuits or components can result in property damage, personal injury or death.	
<ul style="list-style-type: none"> • Service should only be performed by a qualified service technician using proper test equipment. • Altering the water heater controls and/or wiring in any way could result in permanent damage to the controls or water heater and is not covered under the limited warranty. 	
	<p>Any bypass or alteration of the water heater controls and/or wiring will result in voiding the appliance warranty.</p> 

INTRODUCTION

Thank You for purchasing this water heater. Properly installed and maintained, it should give you years of trouble free service.

ABBREVIATIONS USED

Abbreviations found in this Instruction Manual include :

- ANSI - American National Standards Institute
- ASME - American Society of Mechanical Engineers
- AHRI - Air Conditioning, Heating and Refrigeration Institute
- NEC - National Electrical Code
- NFPA - National Fire Protection Association
- UL - Underwriters Laboratory
- CSA - Canadian Standards Association

QUALIFICATIONS

Installation and service of this water heater requires ability equivalent to that of a Qualified Agency (as defined by ANSI below) in the field involved. Installation skills such as plumbing, air supply, venting, gas supply and electrical supply are required in addition to electrical testing skills when performing service.

ANSI Z223.1 2015 Sec. 3.3.81: “Qualified Agency” - “Any individual, firm, corporation or company that either in person or through a representative is engaged in and is responsible for (a) the installation, testing or replacement of gas piping or (b) the connection, installation, testing, repair or servicing of appliances and equipment; that is experienced in such work; that is familiar with all precautions required; and that has complied with all the requirements of the authority having jurisdiction.”

If you are not qualified (as defined by ANSI above) and licensed or certified as required by the authority having jurisdiction to perform a given task do not attempt to perform any of the procedures described in this manual. If you do not understand the instructions given in this manual do not attempt to perform any procedures outlined in this manual.

PREPARING FOR THE INSTALLATION

1. Read the entire manual before attempting to install or operate the water heater. Pay close attention to the **General Safety Information** (page 4). If you don't follow the safety rules, the water heater may not operate safely. It could cause property damage, injury and/or death.
 - This manual contains instructions for the installation, operation, and maintenance of the water heater. It also contains warnings throughout the manual that you must read and be aware of. All warnings and all instructions are essential to the proper operation of the water heater and your safety.
 - Detailed installation diagrams are also found in this manual. These diagrams will serve to provide the installer with a reference. It is essential that all venting, water piping, gas piping, and wiring be installed as shown.

- Particular attention should be given to the installation of thermometers at the locations indicated in the piping diagrams as these are necessary for checking the operation of the water heater.
- The principal components of the water heater are identified in **Features and Components** (page 7) in this manual. Use this reference to locate and identify various components on the water heater.
- See **Troubleshooting** (page 54). By using this checklist the user may be able to make minor operational adjustments and avoid unnecessary service calls. However, service and diagnostic procedures should be performed only by a Qualified Service Agency.

NOTE: Costs to correct installation errors are not covered under the limited warranty. See the Commercial Water Heater Limited Warranty provided with this water heater.

2. Be sure to turn off power when working on or near the electrical system of the water heater. Never touch electrical components with wet hands or when standing in water.
3. The installation must conform to all instructions contained in this manual and the local code authority having jurisdiction. These shall be carefully followed in all cases. Authorities having jurisdiction should be consulted before installation begins if there are any questions regarding compliance with local, state or national codes.
 - In the absence of local codes, the installation must comply with the current editions of the **National Fuel Gas Code, ANSI Z223.1/NFPA 54** and the **National Electrical Code, NFPA 70** or **CAN/CSA-B149.1, the Natural Gas and Propane Installation Code, and CSA C22.1, the Canadian Electrical Code**. All documents are available from the Canadian Standards Association, Corporate Head Office 178 Rexdale Blvd. Toronto, ON Canada M9W 1R3.
 - NFPA documents are also available from the National Fire Protection Association, 1 Batterymarch Park, Quincy, MA 02269.
4. After reading this manual, if you have any questions or do not understand any portion of the instructions, call the toll free number on the back cover of this manual for technical assistance. In order to expedite your request, please have the full Model, Serial and Series numbers of the water heater you are working with available for the technician. This information is located on the water heater's rating label.
5. Carefully plan the placement of the water heater. Examine the location to ensure that it complies with the requirements in **Locating the Water Heater** (page 11) and the **Rough-In Dimensions** (page 10).

6. For installation in California this water heater must be braced or anchored to avoid falling or moving during an earthquake. See instructions for correct installation procedures. Instructions may be obtained from California Office of the State Architect, 1102 Q Street, Suite 5100, Sacramento, CA 95811.

7. Massachusetts Code requires this water heater to be installed in accordance with **Massachusetts 248-CMR 2.00: State Plumbing Code** and **248-CMR 5**. See **Installing Carbon Monoxide Detectors** (page 32).

FEATURES AND COMPONENTS

BASIC OPERATION

This gas water heater combines features of a conventional tank water heater and a tankless water heater to achieve high efficiency as well as high-volume on-demand availability.

When hot water is being used, hot water is drawn from the top of the storage tank. As the tank water is used, it is replenished by cold water from the water supply through the cold water inlet at the bottom of the tank. When the temperature of the water in the storage tank falls below a set point, the controller runs the pump, which draws cold water from either the bottom of the tank or the supply (depending on the hot water draw flow), sends it through the tankless heater, and then to the hot water outlet fitting at the top of the tank.

If hot water is being used, the heated water moves through the outlet fitting to the faucet or appliance. If demand for hot water is high enough, additional hot water is drawn from the top of the tank. If hot water is not being used, the heated water from the tankless unit recirculates back into the tank at the top until the temperature in the tank reaches the set point. See **Figure 3**.

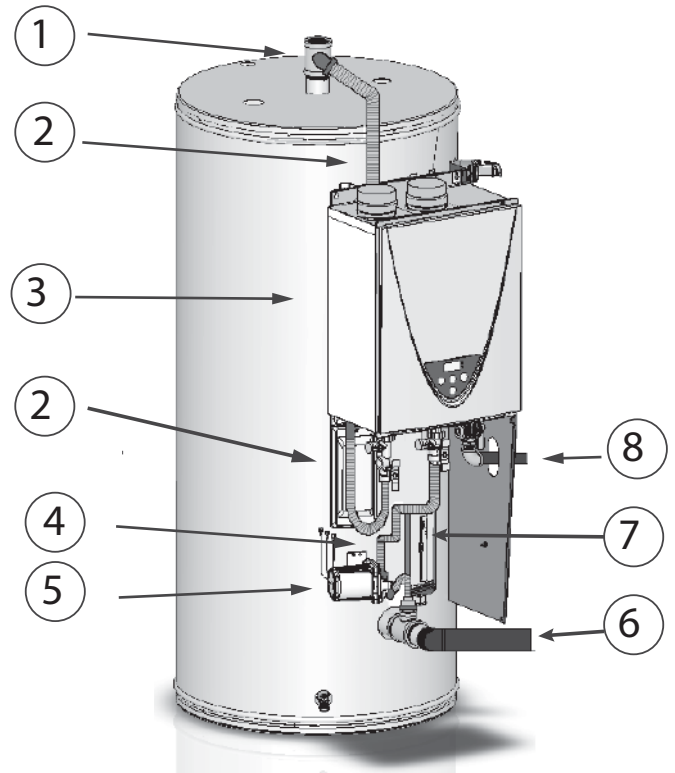

Figure 1. TX1 Components

- | | |
|---|---------------------|
| 1. Hot Water Outlet Fitting | 5. Pump |
| 2. Piping from Water Heating Unit to Tank | 6. Cold Water Inlet |
| 3. Water Heating Unit | 7. Controller |
| 4. Piping from Tank to Pump | 8. Gas Supply |

WATER HEATING UNIT COMPONENTS

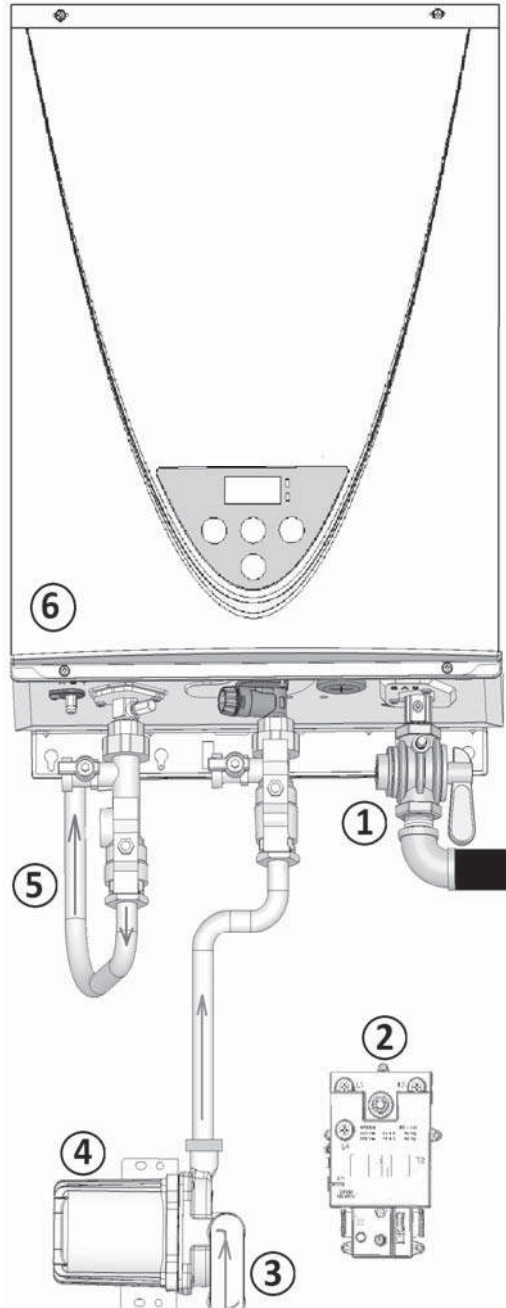

Figure 2. Water Heater Function

- | | |
|-----------------------------------|-----------------------------|
| 1. Gas Supply Valve | 4. Pump |
| 2. Controller | 5. Piping to Outlet Fitting |
| 3. Cold Water from Bottom of Tank | 6. Water Heating Unit |

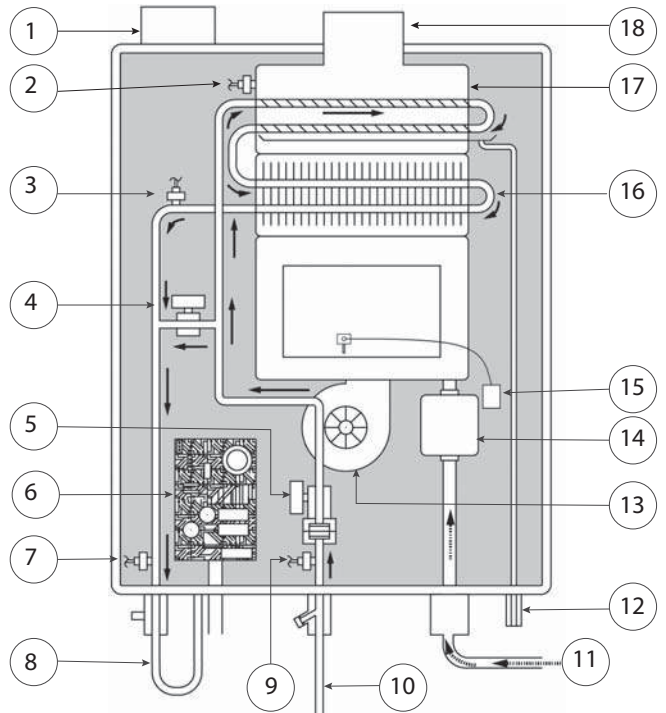

Figure 3. Water Heating Unit

- | | |
|--------------------------------|------------------------------|
| 1. Combustion Air Intake Port | 10. Cold Water Inlet |
| 2. Exhaust Thermistor | 11. Gas Supply Inlet |
| 3. Heated Water Thermistor | 12. Condensate Drain Port |
| 4. Bypass Valve | 13. Fan Motor |
| 5. Water Control Valve | 14. Gas Control Valve |
| 6. Computer Board | 15. Igniter |
| 7. Hot Water Outlet Thermistor | 16. Primary Heat Exchanger |
| 8. Piping to Outlet Fitting | 17. Secondary Heat Exchanger |
| 9. Cold Water Inlet Thermistor | 18. Exhaust Port |

MODULATION

The water heaters covered by this manual are capable of modulating their firing rate. The function of the water heating unit is controlled by a computer printed circuit board. The computer monitors the water temperature measured by the cold water inlet thermistor and hot water outlet thermistor.

Another controller monitors the temperature in the tank. If the tank temperature falls below the set point, this controller runs the pump. As cold water from the bottom of the tank runs into the water heating unit, the thermistors will detect the change in temperature. When the temperatures fall below the set point, the burner is ignited, heating it until the thermistors in the water heating unit and in the tank warm to their set points.

BURNER ASSEMBLY

Spark Igniter

The control system energizes the spark ignition transformer with 120 VAC during the ignition cycle. The spark ignition transformer then sends a high-voltage current to the spark igniter which in turn ignites the main burner air/gas mixture.

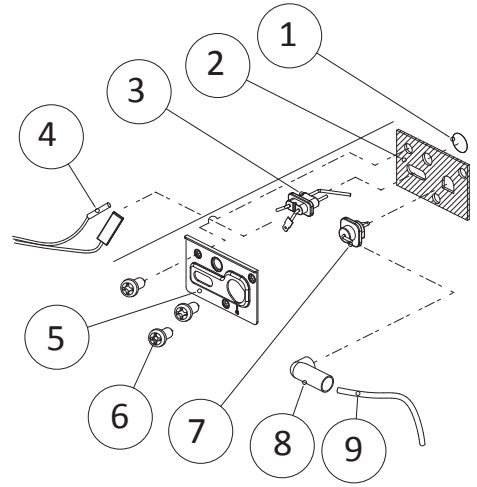

Figure 4. Igniter Assembly

1. Burner Window	6. Pan screw M4x8 MFZN
2. Rod holder gasket	7. Igniter rod
3. Flame rod	8. Rod cap
4. Flame rod wire	9. Igniter assembly
5. Rod holder	

Flame Sensor

The control system also monitors the flame sensor to confirm a flame is present at the main burner. If a flame is not verified during the ignition trial period (3-5 seconds) the control system will immediately close the gas valve.

INSTALLATION CONSIDERATIONS

ROUGH-IN DIMENSIONS

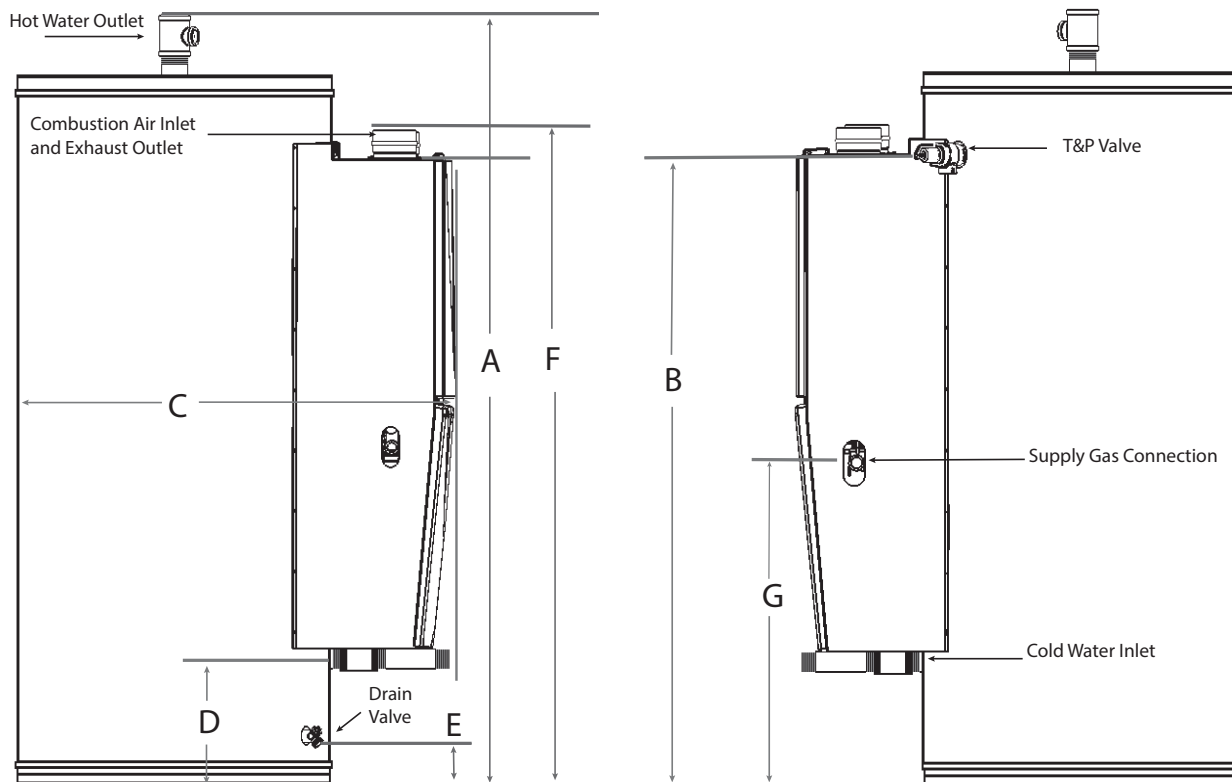

Figure 5. Rough-in Dimensions

Table 1. Dimensions							APPROX. SHIP WEIGHT
A	B	C	D	E	F	G	LBS (KG)
Inches (cm)	Inches (cm)	Inches (cm)	Inches (cm)	Inches (cm)	Inches (cm)	Inches (cm)	
72 (183)	58.7 (149)	41 (104)	11.8 (30)	4.3 (11)	61.38	30 (76)	520(236)

Table 2. GAS PRESSURE REQUIREMENTS

*Manifold Pressure		Minimum Supply Pressure		Maximum Supply Pressure	
NATURAL GAS	PROPANE GAS	NATURAL GAS	PROPANE GAS	NATURAL GAS	PROPANE GAS
2.95" W.C. (0.73 kPa)	3.3" W.C. (0.82 kPa)	4.0" W. C. (1.00 kPa)	8.0" W. C. (1.99 kPa)	10.5" W. C. (2.61 kPa)	14" W. C. (3.49 kPa)

Table 3. RECOVERY CAPACITIES

Type of Gas	Input		Thermal Efficiency%	°F	U. S. Gallons/hr & liters/hr at temperature rise indicated													
					30°F	40°F	50°F	60°F	70°F	80°F	90°F	100°F	110°F	120°F*	130°F*	140°F*		
	Btu/hr	kW			°C	17°C	22°C	28°C	33°C	39°C	44°C	50°C	56°C	61°C	67°C	72°C	78°C	
Natural	199000	58.32	96	GPH	772	579	463	386	331	289	257	232	211	193	178	165		
Propane				LPH	2922	2192	1753	1461	1253	1094	973	878	799	731	674	625		

* inlet water 40° F (22° C)



LOCATING THE WATER HEATER

Carefully choose a location for the new water heater. The placement is a very important consideration for the safety of the occupants in the building and for the most economical use of the water heater.

CAUTION	
Property Damage Hazard	
• All water heaters eventually leak.	
• Do not install without adequate drainage.	

Whether replacing an existing water heater or installing the water heater in a new location observe the following critical points:

1. The water heater must not be located in an area where it will be subject to freezing temperatures.
2. Locate the water heater so it is protected and not subject to physical damage by a moving vehicle.
3. Locate the water heater on a level surface.
4. Locate the water heater near a floor drain. The water heater should be located in an area where leakage of the tank or connections will not result in damage to the area adjacent to the water heater or to lower floors of the structure. When such locations cannot be avoided, it is recommended that a metal drain pan, adequately drained, be installed under the water heater.
5. Locate the water heater close to the point of major hot water usage.
6. Locate the water heater close to a 120 VAC power supply. See **Power Supply** (page 14) for requirements.
7. Locate the water heater where an adequate supply of fresh air for combustion and ventilation can be obtained. See **Air Requirements** (page 30).
8. Locate the water heater where the vent and intake air piping, when installed, will remain within the maximum equivalent lengths allowed. See **Maximum Equivalent Pipe Lengths and Elbows** (page 21).

! WARNING	
Fire or Explosion Hazard	
• Do not store or use gasoline or other flammable vapors and liquids in the vicinity of this or any other appliance.	
• Avoid all ignition sources if you smell gas.	
• Do not expose water heater controls to excessive gas pressure.	
• Use only the gas shown on the water heater rating label.	
• Maintain required clearances to combustibles.	
• Keep ignition sources away from faucets after extended periods of non-use.	
	
Read instruction manual before installing, using or servicing water heater.	

9. There is a risk in using fuel burning appliances such as gas water heaters in rooms, garages or other areas where gasoline, other flammable liquids or engine driven equipment or vehicles are stored, operated or repaired. Flammable vapors are heavy and travel along the floor and may be ignited by the water heater's igniter or Main Burner flames causing fire or explosion.
10. Flammable items, pressurized containers or any other potential fire hazardous articles must never be placed on or adjacent to the water heater.

CLEARANCE TO COMBUSTIBLE MATERIALS

The water heaters covered in this manual are approved for installation on combustible flooring. The clearance to combustible and non combustible construction materials is zero inches on the back and sides of the water heater. These water heaters are also approved for installation in an alcove.

There is a three inch (76 mm) clearance from the left and right sides of the water heating unit to combustible and non-combustible surfaces.

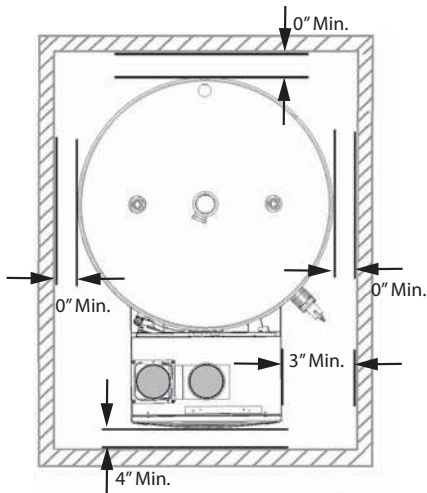

Figure 6. Clearances

Top	Bottom	Front	Sides
4 in. (102 mm)	0 in. (0 mm)	4 in. (102 mm)	0 in. (0 mm)

Note: Adequate clearance for servicing should be maintained on all installations. See *Service Clearance*.

⚠ WARNING

Maintain all clearances around the water heater. Failure to do so could create a fire hazard, potentially leading to death, serious injury, and/or property damage.

When the water heater is installed directly on carpeting, the water heater shall be installed on a metal or wood panel extending beyond the full width and depth of the water heater by at least three inches (76.2 mm) in any direction or, if the water heater is installed in an alcove or closet, the entire floor shall be covered by the panel. The panel must be strong enough to carry the weight of the heater when full of water.

SERVICE CLEARANCE

A service clearance of 24 inches (61 cm) should be maintained from serviceable parts such as the T&P valve, control system components, gas valve, drain valve. A service clearance of 50 inches (127 cm) should be maintained from top for anode replacement.

INTAKE AIR AND VENT PIPE CLEARANCES

The minimum clearance from combustible materials for the vent (exhaust) and intake air piping shall be 0 inches. Vent or intake air piping passing through a combustible wall or ceiling must be a continuous run (no joints).

VENT PIPING OPTIONS

EXTENDED VENT LENGTH

The water heaters covered by this manual can be installed using four-inch pipe for the intake air and/or vent piping up to a maximum of 120 equivalent feet (15.2 m).

Vent terminations are supplied with the heater.

All runs must comply with **Table 7** (page 21).

Contact your local supplier or the parts department to order vent terminals.

OPTIONAL DIRECT VENT TERMINATIONS

The water heaters covered in this manual can be installed in a **direct vent** configuration using optional concentric terminations. See **Concentric Termination Installation Preparation** (page 28).

Concentric terminations must be ordered separately. Contact your local distributor or call the parts department phone number listed on the back cover of this manual to order.

HARD WATER

Where hard water conditions exist, water softening or the threshold type of water treatment is recommended. This will protect the dishwashers, coffee urns, water heaters, water piping and other equipment. See **Maintenance** (page 61) for sediment and lime scale removal procedures.

CIRCULATION PUMPS

A circulating pump is used when a system requires a circulating loop or there is a storage tank used in conjunction with the water heater. See **Water Piping Diagrams** (page 66) for installation location of circulating pumps.

When the water heater is used with a building recirculation system, the building recirculation flow should be no greater than 1 GPM. Also, for maximum energy efficiency, the recirculation system should be on a timer so that it won't run continuously without actual hot water usage.

See **Circulation Pump Wiring Diagrams** (page 65) for electrical hookup information. Install in accordance with the current edition of the **National Electrical Code, NFPA 70** or the **Canadian Electrical Code, CSA C22.1**.

Stainless steel circulating pumps are recommended for use with commercial water heaters.

Refer to the circulating pump manufacturer's instructions for its operation, lubrication, and maintenance instructions.

INSTALLATION REQUIREMENTS



GAS SUPPLY PRESSURE REQUIREMENTS

Low-pressure gas supply systems are defined as those systems that cannot under any circumstances exceed 14" W.C. (1/2 PSI Gauge). These systems do not require pressure regulation. Measurements should be taken to insure that gas pressures are stable and fall within the requirements stated on the water heater rating plate. Take the measurements with all gas burning equipment off (static pressure) and with all gas burning equipment running at maximum rate (dynamic pressure). The gas supply pressure must be stable within 1.5" W.C. from static to dynamic pressure for best performance. Pressure drops that exceed 1.5" W.C. may cause rough starting, noisy combustion or nuisance outages. Increases or spikes in static pressure during off cycles may cause failure to ignite or in severe cases damage to appliance gas valves. If your low-pressure system does **NOT** meet these requirements, the installer is responsible for the corrections.

High Pressure supply systems use pressures that exceed 14" W.C. (1/2 PSI Gauge). These systems must use field-supplied regulators to lower the gas pressure to less than 14" W.C. (1/2 PSI Gauge). Water heaters require gas regulators that are properly sized for the water heater input and deliver the rating-plate specified pressures. Gas supply systems in which the pressure exceeds 5 PSI often require multiple regulators to achieve desired pressures. Systems in excess of 5 PSI pressure should be designed by gas delivery professionals for best performance. Water heaters connected to gas supply systems that exceed 14" W.C. (1/2 PSI Gauge) at any time must be equipped with a gas supply regulator.

WARNING

Breathing, Fire, and Explosion Hazard

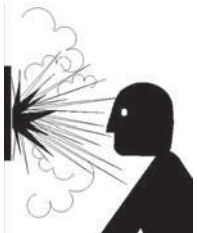
Do not use this water heater with any gas other than the one listed on the rating plate.

Ensure that any and all gas regulators used are operating properly and providing gas pressures within the specified range shown below. Excess gas inlet pressure may cause serious accidents.

Conversion of this unit from natural gas to propane or vice versa will void all warranties. Contact your local distributor to get the correct unit for your gas type. The manufacturer is not liable for any property and/or personal damage resulting from gas conversions.

Failure to observe these warnings could result in severe personal injury, carbon monoxide poisoning, or death.

The following are the minimum and maximum gas pressures required by all models of this appliance:

Table 4. Gas Pressure Parameters by Gas Type	
Gas type	Inlet Gas Pressure
Natural Gas	Min. 4.0" W.C. (1.00 kPa) Max. 10.5" W.C. (2.61 kPa)
Propane	Min. 8.0" W.C. (1.99 kPa) Max. 14.0" W.C. (3.48 kPa)

Note: Fuel conversions are not allowed on this product.

The gas valve has minimum gas supply pressure limits specified in **Table 4**. The minimum supply pressure is measured while gas is flowing (dynamic pressure). The supply pressure should never fall below the minimum specified in the table for each type of gas.

The supply pressure should be measured with all gas fired appliances connected to the common main firing at full capacity. If the supply pressure drops more than 1.5" W.C. as gas begins to flow to the water heater, then the supply gas system, including the gas line and/or the gas regulator may be restricted or undersized. See **Supply Gas Regulator** (page 14).

The gas valve has maximum gas supply pressure limits specified in **Table 4**. The maximum supply pressure is measured while gas is not flowing (static pressure).



Until testing of the main gas line supply pressure is completed, ensure the gas line to the water heater is disconnected to avoid any damage to the water heater.

SUPPLY GAS REGULATOR

1. The maximum allowable gas supply pressure for this water heater using either natural gas or propane is specified in **Table 4**. Install a positive lock-up gas pressure regulator in the gas supply line if inlet gas pressure can exceed these pressures at any time.
2. If a positive lock-up regulator is required, follow these instructions:
 - a. Positive lock-up gas pressure regulators must be capable of going low enough to support the unit at its lowest firing rate.
 - b. Positive lock-up gas pressure regulators must be rated at or above the input Btu/hr rating of the water heater they supply.
 - c. Supply gas regulators shall have inlet and outlet connections not less than the minimum supply gas line size for the water heater they supply. See **Table 19** (page 41) and **Table 20** (page 41).
 - d. Positive lock-up gas pressure regulator(s) should be installed no closer than 3 feet (1 meter) and no farther than 8 feet (2.4 meters) from the water heater's inlet gas connection.
 - e. After installing the positive lock-up gas pressure regulator(s), an initial nominal supply pressure setting of 7.0" W.C. for natural gas and 10" w.c. for propane gas while the water heater is operating is recommended and will generally provide good water heater operation. Some additional adjustments may be required later to maintain a steady gas supply pressure.
 - f. When installing multiple water heaters in the same gas supply system, it is recommended that individual positive lock-up gas pressure regulators be installed at each unit from the supply gas connection on the water heater.

POWER SUPPLY

The water heaters covered in this manual require a 120 VAC, 1Ø (single phase), 60 Hz, 15 amp power supply and must also be electrically grounded in accordance with local codes or, in the absence of local codes, with the **National Electrical Code, ANSI/NFPA 70** or the **Canadian Electrical Code, CSA C22.1**.

 	! WARNING Shock or Electrocution Hazard
	Follow the electrical code requirements of the local authority having jurisdiction. In the absence of such requirements, follow the current edition of the National Electrical Code ANSI/NFPA 70 in the U.S. or the current edition of CSA C22.1 Canadian Electrical Code Part 1 in Canada. When servicing or replacing parts within the water heater, label all wires prior to disconnection to facilitate an easy and error-free reconnection. Wiring errors can cause improper and dangerous operation. Verify proper operation after servicing. Failure to observe these warnings could result in personal injury or death.

DEDICATED POWER WIRING AND BREAKERS

Dedicated power supply wires, neutral wires, ground wiring, and dedicated circuit breakers, often prevent electrical line noise and are required when installing the water heater.

NOTE: This water heater should **not** be connected to an electrical supply with a Ground Fault Circuit Interrupter (GFCI) or Arc Fault Circuit Interrupter (AFCI) with Integral GFCI protection as defined in **NFPA 70, CSA C22.1** and **UL 943**.

POWER FLUCTUATIONS AND ELECTRICAL NOISE

The water heater's control system requires a source of stable clean electricity for proper operation. Connecting the water heater to a branch circuit that is subject to fluctuations in voltage level or electrical line noise such as electromagnetic interference (EMI) or radio frequency interference (RFI) may cause erratic control system operation and malfunction.

A high-quality power supply filter/suppressor must be installed if the above conditions exist. Call the technical support phone number listed on the back cover of this manual or contact a local power filter/suppressor supplier for more information.

NOTE: Malfunctions caused by the power supply and costs to install power supply filters are not covered under the limited warranty. See the Commercial Water Heater Limited Warranty provided with this water heater.

MIXING VALVES

Water heated to a temperature which will satisfy clothes washing, dish washing, and other sanitizing needs can scald and cause permanent injury upon contact. Short repeated heating cycles caused by small hot water uses can cause temperatures at the point of use to exceed the water heater's temperature setting by up to 20°F (11°C).

⚠ DANGER

Water temperature over 125°F (52°C) can cause severe burns instantly resulting in severe injury or death.

Children, the elderly and the physically or mentally disabled are at highest risk for scald injury.

Feel water before bathing or showering.

Temperature limiting devices such as mixing valves must be installed when required by codes and to ensure safe temperatures at fixtures.

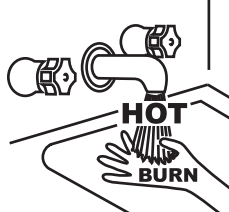

Some people are more likely to be permanently injured by hot water than others. These include the elderly, children, the infirm and the physically/mentally disabled. **Table 5** shows the approximate time-to-burn relationship for normal adult skin. If anyone using hot water provided by the water heater being installed fits into one of these groups or if there is a local code or state law requiring a certain water temperature at the point of use, then special precautions must be taken.

In addition to using the lowest possible temperature setting that satisfies the demand of the application, a mixing valve should be installed at the water heater or at the hot water taps to further reduce system water temperature. See **Figure 7** (page 15).

Mixing valves are available at plumbing supply stores. Consult a Qualified Installer or Service Agency. Follow mixing valve manufacturer's instructions for installation of the valves.

Table 5. Burn Time At Various Temperatures		
Water Temperature °F (°C)	Time for 1st Degree Burn (Less Severe Burns)	Burns 2nd & 3rd Degree (Most Severe Burns)
110 (43)	(normal shower temp.)	
116 (47)	(pain threshold)	
116 (47)	35 minutes	45 minutes
122 (50)	1 minute	5 minutes
131 (55)	5 seconds	25 seconds
140 (60)	2 seconds	5 seconds
149 (65)	1 second	2 seconds
154 (68)	instantaneous	1 second

(U.S. Government Memorandum, C.P.S.C., Peter L. Armstrong, Sept. 15, 1978)

DISH-WASHING MACHINES

All dish-washing machines meeting the **National Sanitation Foundation** requirements are designed to operate with water flow pressures between 15 and 25 pounds per square inch (103 kPa and 173 kPa). Flow pressures above 25 pounds per square inch (173 kPa), or below 15 pounds per square inch (103 kPa), will result in improperly sanitized dishes. Where pressures are high, a water pressure reducing or flow regulating control valve should be used in the 180°F (82°C) line to the dish-washing machine and should be adjusted to deliver water pressure between these limits.

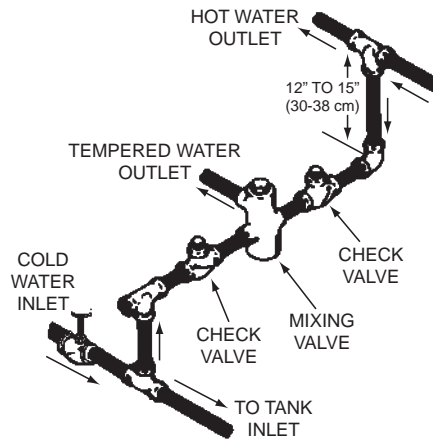

Figure 7. Mixing Valve

The **National Sanitation Foundation** also recommends circulation of 180°F (82°C) water. The circulation should be just enough to provide 180°F (82°C) water at the point of take-off to the dish-washing machine.

Adjust flow by throttling a full-port ball valve installed in the circulating line on the outlet side of the pump. Never throttle flow on the suction side of a pump. See the **Water Piping Diagrams** (page 66).

NOTE: To comply with **NSF Standard 5** installation requirements, the bottom of the water heater must be sealed to the floor with a silicone based sealant or elevated 6 inches above the floor.

CLOSED WATER SYSTEMS

Water supply systems might have pressure reducing valves, check valves, or back flow preventers installed to meet code requirements or to adapt to such conditions as high line pressure, among others. Devices such as these cause the water system to be a closed system. If the water system is closed, thermal expansion can occur.

THERMAL EXPANSION

As water is heated, it expands (thermal expansion). In a closed system, as the volume of water grows, a corresponding increase in water pressure occurs. The increased pressure caused by the thermal expansion can cause premature tank failure (leakage). This type of failure is not covered under the limited warranty. Thermal expansion can also cause intermittent water discharge from the Temperature-Pressure Relief Valve: water discharged from the valve due to excessive pressure build up. This condition is not covered under the limited warranty. See the Commercial Water Heater Limited Warranty provided with this water heater.

The Temperature-Pressure Relief Valve is not intended for the constant relief of thermal expansion.

A thermal expansion tank provides a way to absorb excess pressure caused by thermal expansion. A properly sized and pressurized thermal expansion tank must be installed on all closed systems to control the harmful effects of thermal expansion. Contact a local plumbing service agency to have a thermal expansion tank installed.

See **Water Line Connections** (page 44) and the **Water Piping Diagrams** (page 66).

SAFETY VALVE REQUIREMENTS

The water heaters covered by this manual require the following safety valves:

- A pressure-only relief valve between the water heating unit outlet fitting and the outlet fitting at the top of the storage tank
- A Temperature and Pressure Relief valve on the storage tank in the customary position

WATER HEATING UNIT PRESSURE-ONLY RELIEF VALVE

The water heater has a high-temperature shutoff switch built in as a standard safety feature (called a Hi-Limit switch) therefore a “pressure only” relief valve is required.

This unit does not come with an approved pressure relief valve, so this must be field supplied.

An approved pressure relief valve must be installed on the water heating unit hot water outlet. The pressure relief valve must conform to **ANSI Z21.22** or **CAN 1-4.4** and installation must follow local codes. The discharge capacity must be at least 199,000 BTU/h. The pressure relief valve needs to be rated for a maximum of 150 psi (1 MPa).

The discharge piping for the pressure relief valve must be directed so that the hot water cannot splash outward and cause damage or personal injury.

Attach the discharge tube to the pressure relief valve and run the end of the tube to within 6 in (152 mm) from the floor. This discharge tube must allow free and complete drainage without any restrictions.

If the pressure relief valve discharges periodically, this may be due to thermal expansion in a closed water supply system. See **Thermal Expansion** (page 15) and/or contact the water supplier or a local plumbing professional on how to correct this situation.

Do not plug the pressure relief valve.

The pressure relief valve must be manually operated periodically to check for correct operation. Before operating the valve manually, check that it will discharge in a place for secure disposal.

No valve must be placed between the relief valve and the water heating unit.

TEMPERATURE-PRESSURE RELIEF VALVE

This water heater is provided with a properly rated/sized and certified combination Temperature-Pressure Relief Valve (T&P valve) by the manufacturer. The valve is certified by

a nationally recognized testing laboratory that maintains periodic inspection of production of listed equipment of materials as meeting the requirements for Relief Valves for Hot Water Supply Systems, **ANSI Z21.22 • CSA 4.4**, and the code requirements of **ASME**.

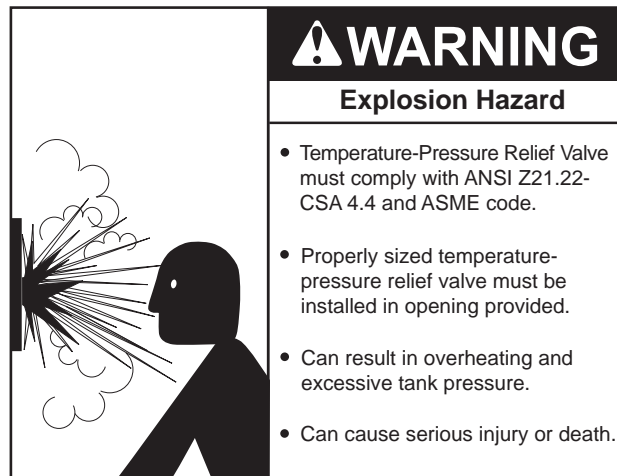

If replaced, the new T&P valve must meet the requirements of local codes, but not less than a combination Temperature-Pressure Relief Valve rated/sized and certified as indicated in the above paragraph. The new valve must be marked with a maximum set pressure not to exceed the marked hydrostatic working pressure of the water heater (150 psi = 1,035 kPa) and a discharge capacity not less than the water heater Btu/hr or kW input rate as shown on the water heater's model rating label.

NOTE: In addition to the factory installed Temperature-Pressure Relief Valve on the water heater, each remote storage tank that may be installed and piped to a water heating appliance must also have its own properly sized, rated and approved Temperature-Pressure Relief Valve installed. Call the toll free technical support phone number listed on the back cover of this manual for technical assistance in sizing a Temperature-Pressure Relief Valve for remote storage tanks.

For safe operation of the water heater, the Temperature-Pressure Relief Valve must not be removed from its designated opening nor plugged. The Temperature-Pressure Relief Valve must be installed directly into the fitting of the water heater designed for the relief valve. Install discharge piping so that any discharge will exit the pipe within 6 inches (15.2 cm) above an adequate floor drain, or external to the building. In cold climates, it is recommended that it be terminated at an adequate drain inside the building. Be certain that no contact is made with any live electrical part. The discharge opening must not be blocked or reduced in size under any circumstances. Excessive length, over 30 feet (9.14 m), or use of more than four elbows can cause restriction and reduce the discharge capacity of the valve.

No valve or other obstruction is to be placed between the Temperature-Pressure Relief Valve and the tank. Do not

connect discharge piping directly to the drain unless a 6" (15.2 cm) air gap is provided. To prevent bodily injury, hazard to life, or property damage, the relief valve must be allowed to discharge water in adequate quantities if circumstances demand. If the discharge pipe is not connected to a drain or other suitable means, the water flow may cause property damage.

CAUTION
Water Damage Hazard
<ul style="list-style-type: none"> • Temperature-Pressure Relief Valve discharge pipe must terminate at adequate drain.

T&P VALVE DISCHARGE PIPE REQUIREMENTS

- Shall not be smaller in size than the outlet pipe size of the valve, or have any reducing couplings or other restrictions.
- Shall not be plugged or blocked.
- Shall not be exposed to freezing temperatures.
- Shall be of material listed for hot water distribution.
- Shall be installed so as to allow complete drainage of both the Temperature-Pressure Relief Valve and the discharge pipe.
- Must terminate a maximum of six inches above a floor drain or external to the building. In cold climates, it is recommended that the discharge pipe be terminated at an adequate drain inside the building.
- Shall not have any valve or other obstruction between the relief valve and the drain.

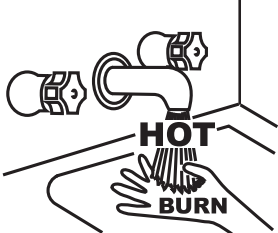
⚠ DANGER	<ul style="list-style-type: none"> • Burn hazard. • Hot water discharge. • Keep clear of Temperature-Pressure Relief Valve discharge outlet.
	

The Temperature-Pressure Relief Valve must be manually operated at least twice a year. Caution should be taken to ensure that (1) no one is in front of or around the outlet of the Temperature-Pressure Relief Valve discharge line, and (2) the water manually discharged will not cause any bodily injury or property damage because the water may be extremely hot. If after manually operating the valve, it fails to completely reset and continues to release water, immediately close the cold water inlet to the water heater,

follow the draining instructions in this manual, and replace the Temperature-Pressure Relief Valve with a properly rated/ sized new one.

NOTE: The purpose of a Temperature-Pressure Relief Valve is to prevent excessive temperatures and pressures in the storage tank. The T&P valve is not intended for the constant relief of thermal expansion. A properly sized thermal expansion tank must be installed on all closed systems to control thermal expansion, see *Thermal Expansion and Closed Water Systems* (page 15).

If you do not understand these instructions or have any questions regarding the Temperature-Pressure Relief Valve, call the toll free number listed on the back cover of this manual for technical assistance.

CONDENSATE DRAIN

The water heaters covered in this manual require a drain near the water heater to allow the condensate to drain safely. The condensate accumulates as a by-product of combustion. Condensate drains from the water heating unit through a drain tube to the drain. The condensate drain tube must leave an air gap of two inches and must not be elevated above the condensate drain connection.

If the condensate does not drain properly, it will build up in the water heating unit and interfere with its function.



CONDENSATE PH LEVEL

The condensate that drains from the water heater's covered in this manual have pH levels between 4.3 and 5.0. Install a commercially available neutralizing kit if required by local codes.

NOTE: Lower pH levels are acidic. Do not connect a metal drain line, such as copper, to the water heater for this reason. See *Water Heating Unit Condensate Drain* (page 37).

COMBUSTIBLE MATERIAL STORAGE

Remove any combustible materials, gasoline or any flammable vapors and liquids.



 WARNING	
Fire or Explosion Hazard	
<ul style="list-style-type: none"> • Do not store or use gasoline or other flammable vapors and liquids in the vicinity of this or any other appliance. • Avoid all ignition sources if you smell gas. • Do not expose water heater controls to excessive gas pressure. • Use only the gas shown on the water heater rating label. • Maintain required clearances to combustibles. • Keep ignition sources away from faucets after extended periods of non-use. 	
	
<p>Read instruction manual before installing, using or servicing water heater.</p>	

Keep water heater area clear and free of combustible materials, gasoline, and other flammable vapors and liquids.

VENTILATION REQUIREMENTS

COMBUSTION AIR SUPPLY

Before installing the water heater, you must determine the amount of air needed to supply this water heater and any other gas appliances in the same area and provide adequate air for combustion and ventilation. Consult a qualified person if you're unsure of the proper way to supply air to your water heater.

 WARNING	
Breathing Hazard	
	<p>This gas water heater requires an adequate source of clean air for combustion and ventilation. Without sufficient air, your water heater may not operate properly and may emit excessive and abnormal amounts of carbon monoxide which may result in carbon monoxide poisoning or death.</p>
<p>Breathing carbon monoxide can cause brain damage or death. Always read and understand the instruction manual.</p>	

The guidelines in this section apply to installations within the United States. All U.S. installations must conform to the **National Fuel Gas Code, ANSI Z223.1/NFPA 54** (current edition) and local codes.

Canadian requirements differ from the guidelines in this section. In Canada, follow the requirements of **B149.1 (Natural Gas and Propane Installation Code, current edition)** as well as local and provincial codes. Contact your local code enforcement agency for direction.

Check for Chemicals

Air for combustion and ventilation must be clean and free of corrosive chemicals. If corrosive chemicals, such as sulfur, flourine, or chlorine are present, the water heater must be direct vented. Failure of the water heater due to these corrosive chemicals is not covered by the warranty.

WARNING!: In all cases, ensure that corrosive chemicals are not present at the air intake. Presence of such chemicals at the air intake could result in death, personal injury, or property damage. Examples of locations that require outside air due to chemicals include:

- Beauty salons
- Photo processing labs
- Indoor pools
- Laundry, hobby, or craft rooms
- Chemical storage areas

Products such as aerosol sprays, detergents, bleaches, cleaning solvents, gasoline, air fresheners, paint and varnish removers, and refrigerants should not be stored or used near the water heater.

Does your installation space have sufficient combustion air?

Ventilation with outside air is recommended for all installations. Even if the water heater is installed in a large, open room inside the house, outdoor air is usually needed because modern homes are very tightly sealed and often do not supply enough air to the water heater. However, when installed in a large indoor space, it may be possible to provide enough air without outside ventilation. If you are unsure if your installation location has enough ventilation, contact your local gas utility company or code officials for a safety inspection or direct vent the water heater

The following instructions will help determine if it may be possible to install the water heater without outside ventilation.

Calculate Total BTU/h Rating of All Appliances

To calculate the combustion air and ventilation required, add up the total BTU/h ratings of all gas burning appliances (e.g., water heaters, furnaces, clothes dryers) in the same area. Do not include appliances that are direct vented. Refer to the following example.

Your water heater's BTU/h rating is on the rating plate. The BTU/h ratings should be on the other appliances' rating plates. If you have trouble determining the BTU/h ratings, contact the manufacturer or have a qualified person determine the ventilation requirements.

NOTICE: If you are replacing your old water heater with one that has a higher BTU/h rating, the amount of ventilation required may be greater.

Example:

Gas Water Heater	199,000
Furnace	75,000
Dryer	20,000
Total	294,000

Worksheet for Your Appliances:

Gas Water Heater	
Total	

Calculate the Air Volume of the Room

Air requirements depend on the size of the room.

Room Volume (ft³) = Floor Area (ft²) X Ceiling Height (ft)

If there are large objects in the room (e.g., refrigerator, furnace, car), subtract their volume from the volume of the room to get a better estimate of the air available.

Air Volume = Room Volume - Object Volume

NOTE: Adjoining rooms with permanently opened doorways can be counted as part of the calculation.

Calculate Required Air Volume

A water heater installed in an unconfined attic, garage, or space requires that the space be at least 50 ft³ (1.42 m³) per 1,000 BTU/h of the total input for all gas burning appliances in the same area.

Required Air Volume (ft³) = Total Appliance Energy Rating (btu/h) X 50 ft³ / 1000 (btu/h)

Example:

(294,000 / 1000) x 50 = 14,700 ft³

If the air volume of the room is less than the required air volume, you must direct vent the water heater or provide permanent outside air openings that draw in sufficient air. See **Install with Outside Ventilation** (page 19) if you want to provide combustion air with outside ventilation.

If the air volume of the room is greater than the required air volume, it may be possible to install the water heater without outside ventilation. However, be sure to consider the effects of exhaust fans.

Exhaust fans can affect the amount of combustion air that is available in your home. Appliances such as furnaces, whole house fans, and clothes dryers draw air out of your home. If they draw air out faster than it can be replaced, your water heater may not have enough oxygen to fire properly. Back-drafting may also result, which is when negative air pressure pulls air backwards through chimneys or appliance vents. These events can cause unsatisfactory water heater

performance. The best solution is to direct vent the water heater or install an adequate number of make-up air vents. See **Install with Outside Ventilation** (page 19). For more information, consult a qualified technician or your local gas utility.

Install with Outside Ventilation

Ventilation with outside air is recommended, and, for most installations, is needed. There may be existing ventilation that is adequate, or you may need to add more ventilation.

Supplying outside air to the water heater typically requires two openings. One opening must be within 12 in (305 mm) from the floor and the second opening must be within 12 in (305 mm) from the ceiling. Although a single opening is not preferred, you may use a single opening to outside air if the minimum free area is sized according to **Table 6**. Two openings must be used when ventilating with air from another room.

The outside air can be taken from a crawl space or attic open to the outdoors and adequately ventilated. You may use vertical or horizontal ducts.

Determine Type of Ventilation

There are several types of ventilation that can be used. The following are the various ventilation options.

1. Direct to outdoors
2. Vertical ducts
3. Horizontal ducts
4. Single opening (not recommended; must be at least 100 in² (6.5 cm²) . Not appropriate for confined spaces smaller than 50 ft³ (1.42 m³) per 1,000 BTU/h or when getting air from another room.)
5. From a larger room inside the house (not recommended – refer to "Calculate the air volume of the room" above to determine if the combined volume of the rooms may be adequate).

See also the illustrations on the next page.

Determine Minimum Free Area Required for Each Vent Opening

The size of the vent openings depends on the total BTU/h rating of all appliances in the space (use your calculation from "Before beginning") and the type of vent used. **Table 6** provides the minimum free area for each vent opening depending on the type of ventilation.

Calculate Minimum Size of Vent Openings and Ducts

The vent cross-sectional area needed to provide the free area depends on the covering on the vent openings. Typical vents use louvers or grilles to protect the opening. The louver or grill itself blocks some of the free area, so the opening may need to be larger to meet the minimum free area requirements.

Use the following formula to calculate the required cross-sectional area:

Cross-sectional area = minimum free area required ÷ percent free area of covering (in decimals – e.g., 60 % = 0.6)

For example, an installation area that requires openings with 100 in² (645 cm²) of free area would need 134 in² (865 cm²) openings if using metal louvers rated at 75% free area (100 in² ÷ 0.75 = 134 in²).

If you do not know the % free area for your louver or grill, use the following values:

- For wood louvers or grilles: 25%
- For metal louvers or grilles: 75%

Follow these rules to ensure that vents and ducts provide adequate air flow:

- Each vent opening must be no smaller than 100 in² (645 cm²).
- Ducts must have the same cross-sectional area as free area of the opening.
- Rectangular ducts must have a minimum dimension of no less than 3 in (76 mm).
- All screens must have mesh ¼” or larger.
- Moveable louvers must be locked open or interconnected with the equipment so that they open automatically during operation.
- Keep louvers and grills clean and free of debris or other obstructions.

Check that Air Source is Clean and Free of Chemicals

Air for combustion and ventilation must be clean and free of corrosive or flammable chemicals. A failure due to corrosive chemicals in the air is not covered by the warranty. Combustion air must be free of acid-forming chemicals such as sulfur, fluorine, and chlorine. Be sure that air at the vent inlets is free of such chemicals.

Table 6 shows the minimum free area of permanent openings for ventilation and combustion air supply with air from outdoor or indoor spaces. The values are based on the total BTU/h input rating for all gas burning appliances within a confined space.

Opening Source	Minimum Free Area
Direct to outdoors*	1 in ² (6.5 cm ²) per 4,000 BTU/hr (See Figure 8 and Figure 9 .)
Vertical ducts	1 in ² (6.5 cm ²) per 4,000 BTU/hr (See Figure 13 .)
Horizontal ducts	1 in ² (6.5 cm ²) per 2,000 BTU/hr (See Figure 10 .)
Single Opening	1 in ² (6.5 cm ²) per 3,000 BTU/hr (See Figure 11 .)
Two permanent openings to another room**	1 in ² (6.5 cm ²) per 1,000 Btu/hr (See Figure 12 .) Opening: 100 in ² (645 cm ²) MIn Minimum dimension of air openings: no less than 3 in (76 mm)

*These openings connect directly with the outdoors through a ventilated attic, a ventilated crawl space, or through an outside wall.
United States: For direction on combining spaces in different stories within the structure, refer to the current edition of the **National Fuel Gas Code ANSI Z223.1/NFPA 54. In Canada, contact your local code enforcement agency for direction.

Combustion Air Supply Options

Figure 8 through **Figure 12** illustrate the range of methods available for ensuring adequate combustion air for the water heater.

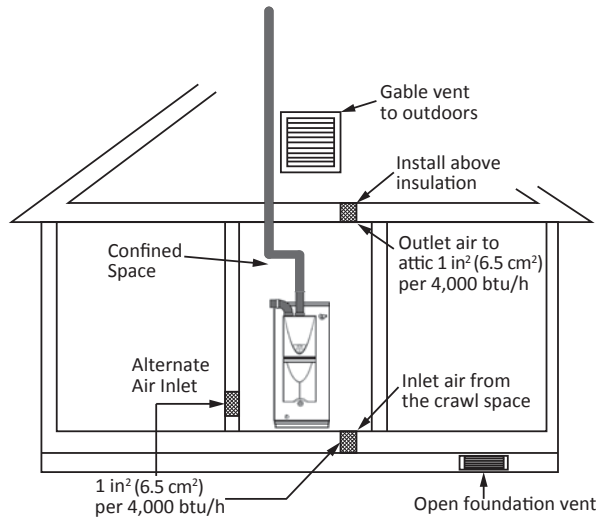

Figure 8. Air from Outdoors Openings

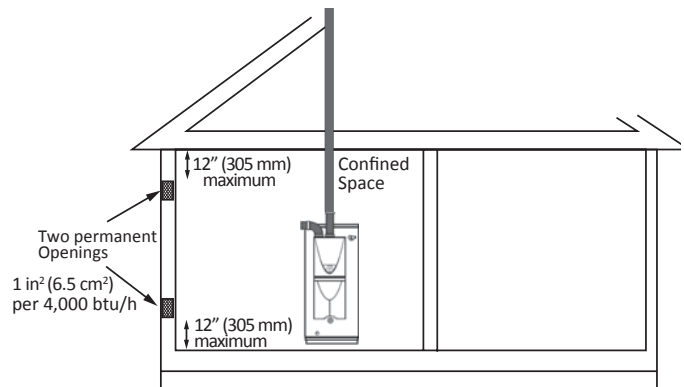

Figure 9. Outdoor Air Through Two Openings

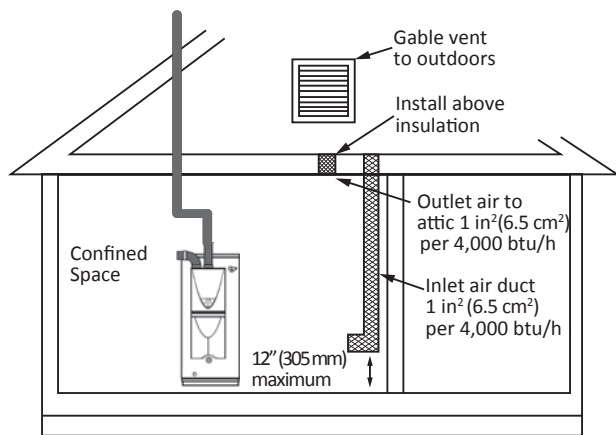

Figure 10. Vertical Duct Openings

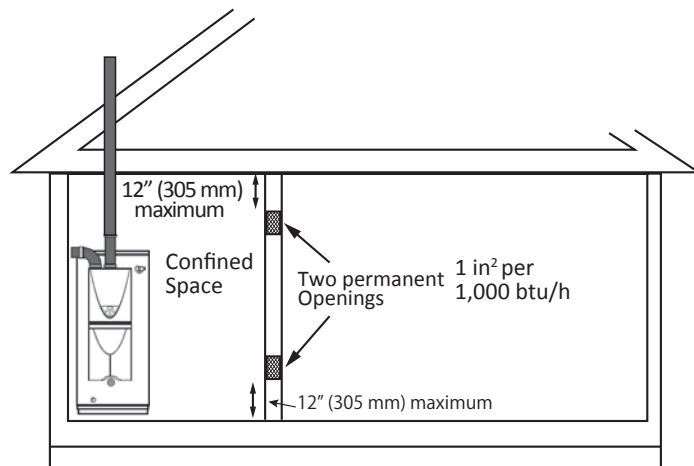

Figure 13. Indoor Air Through Two Permanent Openings

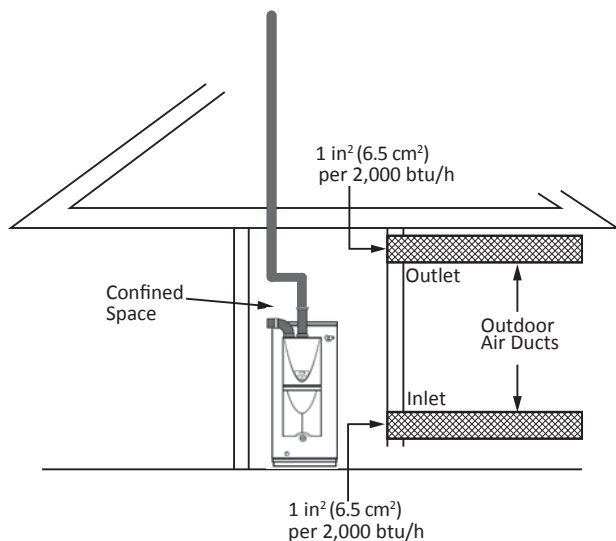

Figure 11. Horizontal Duct Openings

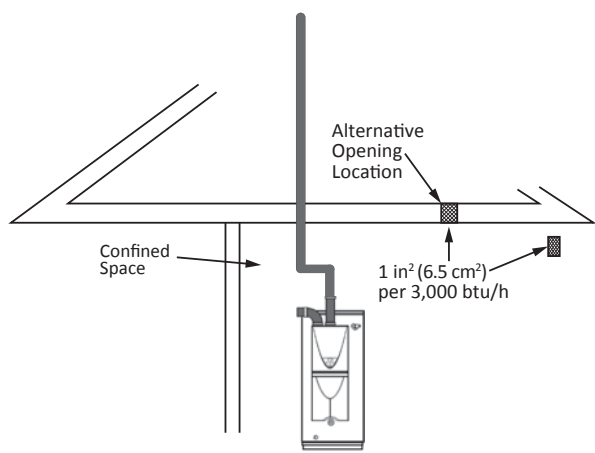

Figure 12. Outdoor Air Through One Opening

MAXIMUM EQUIVALENT PIPE LENGTHS AND ELBOWS

The maximum length of exhaust vent piping must not exceed 70 ft (21.3 m) for 3" venting, which depends on the elevation where the water heater is installed, and 100 ft (30.5 m) for 4" venting (deducting 5 ft (1.5 m) for each elbow used in the venting system). Do not use more than 5 elbows. See **Table 7**.

When the horizontal vent run exceeds 5 ft (1.5 m), support the vent run at 3 ft (0.9 m) intervals with overhead hangers.

Table 7. Equivalent Lengths and Maximum Number of Elbows

No. of Elbows	3" (76 mm) Venting			4" (102 mm) Venting
	0 to 3,000 ft (0 to 914 m)	3,001 to 6,000 ft (915 to 1,829 m)	6,001 to 10,100 ft (1,830 to 3,078 m)	0 to 10,100 ft (0 to 3,078 m)
0	70 ft (21.3 m)	40 ft (12.2 m)	25 ft (7.6 m)	100 ft (30.5 m)
1	65 ft (19.8 m)	35 ft (10.7 m)	20 ft (6.1 m)	95 ft (29.0 m)
2	60 ft (18.3 m)	30 ft (9.1 m)	15 ft (4.6 m)	90 ft (27.4 m)
3	55 ft (16.8 m)	25 ft (7.6 m)	10 ft (3.0 m)	85 ft (25.9 m)
4	50 ft (15.2 m)	20 ft (6.1 m)	N/A	80 ft (24.4 m)
5	45 ft (13.7 m)	N/A	N/A	75 ft (22.9 m)

Excludes vent terminators, termination elbows, or rain caps.

Diameter	Max. No. of Elbows	Max. Vertical and Horizontal (Total) Vent Length
3 in. (76 mm)	5	70 ft (21.3 m)
4 in. (102 mm)	5	100 ft (30.5 m)

*For each elbow added, deduct 5 ft. (1.5 m) from max. vent length.

DIRECT VENT INSTALLATIONS

TWO-PIPE, DIRECT-VENT INSTALLATION

For details of the optional items, refer to the Installation manual for each optional item.

HOW TO INSTALL A TWO-PIPE, DIRECT-VENT SYSTEM

Install as shown in the following figures. See **Clearances For Rooftop Terminations** (page 36) for the proper clearances.

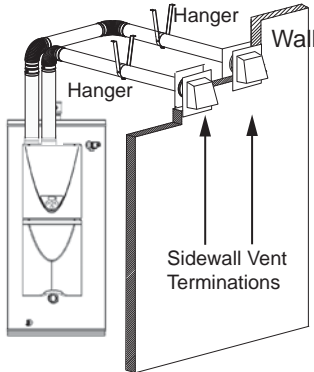

Figure 14. Two-Pipe Horizontal Installation

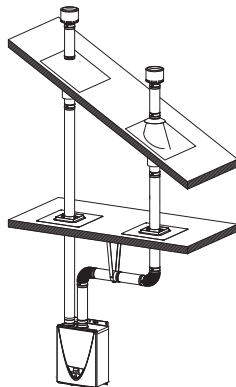

Figure 15. Two-Pipe Vertical Installation

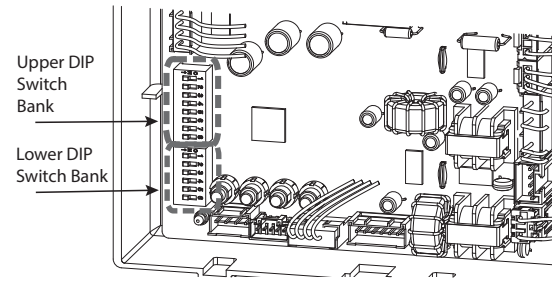

Figure 16. Location of DIP Switches

Installing a Three-Inch (76 mm) Direct Vent Connection

1. Connect 3" (76 mm) couplings directly on the exhaust and intake vent collar of the water heater.
2. Connect 3" (76 mm) straight pipes to the couplings.
3. Locate lower bank of DIP switches and set the appropriate switches for this configuration. See the appropriate settings below.

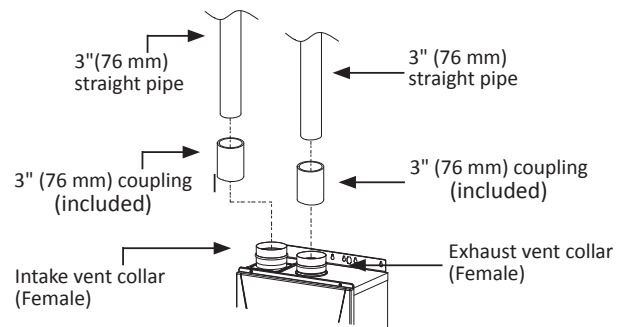

Figure 17. 3" (76 mm) Vent Connection

Table 8. DIP Switch Settings: Three-Inch Direct Vent

5 to 20 ft (1.5 to 6.1 m) (DEFAULT)	21 to 40 ft (6.2 to 12.2 m)	41 to 70 ft (12.3 to 21.3 m)
ON 1 2 3 4 5 6 7 8 OFF [Diagram showing switches 1, 2, 3, 4, 5, 6, 7, 8 in various states]	ON 1 2 3 4 5 6 7 8 OFF [Diagram showing switches 1, 2, 3, 4, 5, 6, 7, 8 in various states]	ON 1 2 3 4 5 6 7 8 OFF [Diagram showing switches 1, 2, 3, 4, 5, 6, 7, 8 in various states]
No. 3 : O N No. 4 : O F F	No. 3 : O F F No. 4 : O F F	No. 3 : O N No. 4 : O N

Installing a Four-Inch (102 mm) Direct Vent Connection

1. Connect 3"x 4" (76 x 102 mm) adaptors directly on the exhaust and intake vent collar of the water heater.
2. Connect 4" (102 mm) straight pipes to the adaptors.
3. Locate lower bank of DIP switches and set the appropriate switches for this configuration. See the appropriate settings below.

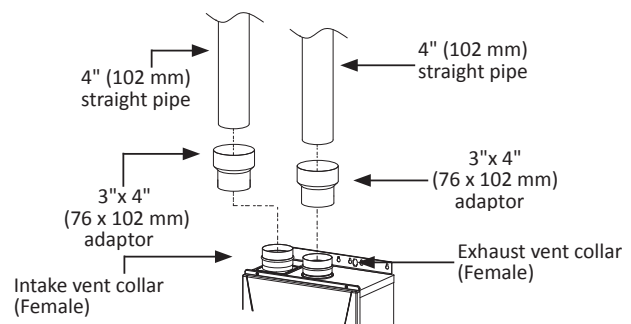



Figure 18. Four-Inch (102 mm) Two-Pipe Vent Connection

! WARNING

Breathing Hazard



- Adjust the appropriate DIP switches according to model and vent length as shown. DO NOT adjust the other DIP switches.
- Turn off the power supply to the water heater before changing the DIP switch settings.
- Failure to observe these warnings could lead to carbon monoxide poisoning or death.

Breathing carbon monoxide can cause brain damage or death. Always read and understand the instruction manual.

Table 9. DIP Switch Settings: Four-Inch Direct Vent

5 to 50 ft (1.5 to 15.2m) (DEFAULT)	51 to 100 ft (15.3 to 30.5 m)
ON <input type="checkbox"/> 1 <input type="checkbox"/> 2 <input type="checkbox"/> 3 <input type="checkbox"/> 4 <input type="checkbox"/> 5 <input checked="" type="checkbox"/> 6 <input type="checkbox"/> 7 <input type="checkbox"/> 8 <input type="checkbox"/> 9 <input type="checkbox"/> 10 OFF <input type="checkbox"/> 1 <input type="checkbox"/> 2 <input type="checkbox"/> 3 <input type="checkbox"/> 4 <input type="checkbox"/> 5 <input type="checkbox"/> 6 <input type="checkbox"/> 7 <input type="checkbox"/> 8 <input type="checkbox"/> 9 <input type="checkbox"/> 10	ON <input type="checkbox"/> 1 <input type="checkbox"/> 2 <input type="checkbox"/> 3 <input type="checkbox"/> 4 <input type="checkbox"/> 5 <input checked="" type="checkbox"/> 6 <input checked="" type="checkbox"/> 7 <input type="checkbox"/> 8 <input type="checkbox"/> 9 <input type="checkbox"/> 10 OFF <input type="checkbox"/> 1 <input type="checkbox"/> 2 <input type="checkbox"/> 3 <input type="checkbox"/> 4 <input type="checkbox"/> 5 <input type="checkbox"/> 6 <input type="checkbox"/> 7 <input type="checkbox"/> 8 <input type="checkbox"/> 9 <input type="checkbox"/> 10
No. 6 : ON No. 7 : OFF	No. 6 : OFF No. 7 : OFF

SINGLE-VENT INSTALLATIONS

HOW TO INSTALL A SINGLE-PIPE WITH ROOM-AIR INTAKE INSTALLATION

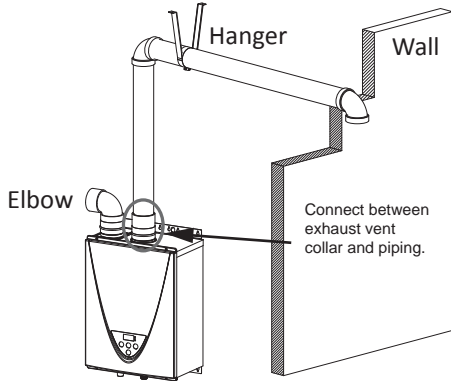

Figure 19. Single-Pipe Horizontal Installation

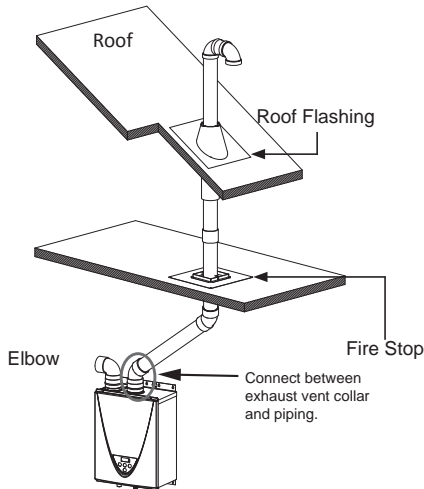

Figure 20. Single-Pipe Vertical Installation

! **WARNING**

Breathing Hazard

- Adjust the appropriate DIP switches according to model and vent length as shown below. **DO NOT** adjust the other DIP switches.
- Turn off the power supply to the water heater before changing the DIP switch settings.
- Failure to observe these warnings could lead to carbon monoxide poisoning or death.

Breathing carbon monoxide can cause brain damage or death. Always read and understand the instruction manual.

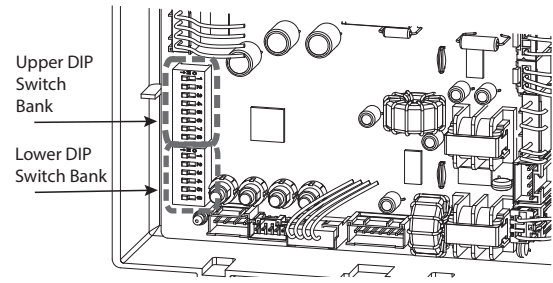

Figure 21. Location of DIP Switches

How to Install a Three-Inch Single-Vent Installation

1. Connect a 3" (76 mm) elbow directly on the intake vent collar of the water heater.
2. Connect a 3" (76 mm) coupling directly on the exhaust vent collar of the water heater.
3. Connect a 3" (76 mm) straight pipe to the coupling.
4. Locate lower bank of DIP switches and set the appropriate switches for this configuration. See the appropriate settings below.

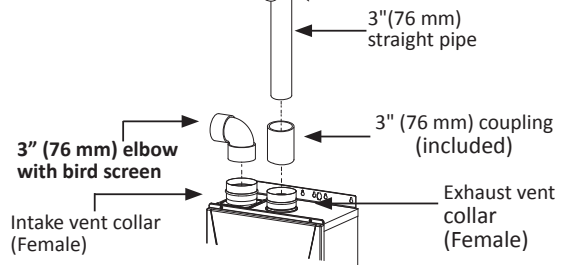

Figure 22. Three-Inch (76 mm) Vent Connection

Table 10. DIP Switch Settings: Three-Inch Single-Vent Pipe

5 to 45 ft (1.5 to 13.7m) (DEFAULT)	46 to 70 ft (13.8 to 21.3 m)
ON <input type="checkbox"/> 1 <input type="checkbox"/> 2 <input type="checkbox"/> 3 <input type="checkbox"/> 4 <input type="checkbox"/> 5 <input checked="" type="checkbox"/> 6 <input type="checkbox"/> 7 <input type="checkbox"/> 8 <input type="checkbox"/> 9 <input type="checkbox"/> 10 OFF <input type="checkbox"/> 1 <input type="checkbox"/> 2 <input type="checkbox"/> 3 <input type="checkbox"/> 4 <input type="checkbox"/> 5 <input type="checkbox"/> 6 <input type="checkbox"/> 7 <input type="checkbox"/> 8 <input type="checkbox"/> 9 <input type="checkbox"/> 10	ON <input type="checkbox"/> 1 <input type="checkbox"/> 2 <input type="checkbox"/> 3 <input type="checkbox"/> 4 <input type="checkbox"/> 5 <input checked="" type="checkbox"/> 6 <input type="checkbox"/> 7 <input type="checkbox"/> 8 <input type="checkbox"/> 9 <input type="checkbox"/> 10 OFF <input type="checkbox"/> 1 <input type="checkbox"/> 2 <input type="checkbox"/> 3 <input type="checkbox"/> 4 <input type="checkbox"/> 5 <input type="checkbox"/> 6 <input type="checkbox"/> 7 <input type="checkbox"/> 8 <input type="checkbox"/> 9 <input type="checkbox"/> 10
No. 6 : ON No. 7 : OFF	No. 6 : OFF No. 7 : OFF

How to Install a Four-Inch Single-Vent Installation

1. Connect a 3" (76 mm) elbow directly on the intake vent collar of the water heater.
2. Connect a 3" x 4" (76 x 102 mm) adaptor directly on the exhaust vent collar of the water heater.
3. Connect a 4" (102 mm) straight pipe to the adaptor.
4. Locate lower bank of DIP switches and set the appropriate switches for this configuration. See the appropriate settings below.

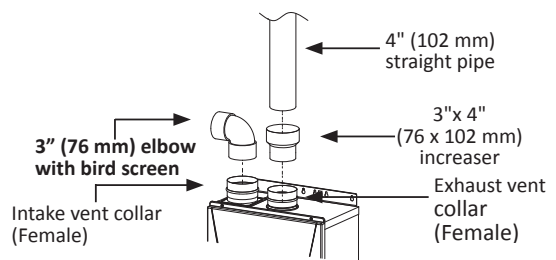

Figure 23. Four-Inch (102 mm) Vent Connection

Table 11. DIP Switch Settings: Four-Inch Single-Vent Pipe

5 to 50 ft (1.5 to 15.2m) (DEFAULT)	51 to 100 ft (15.3 to 30.5 m)
No. 6 : O N No. 7 : OFF	No. 6 : OFF No. 7 : OFF

STAINLESS STEEL VENT INSTALLATIONS

This is a Category IV appliance and must be vented accordingly. The vent system must be sealed airtight. All seams and joints without gaskets must be sealed with high heat resistant silicone sealant or UL listed aluminum adhesive tape having a minimum temperature rating of 160 °F (71 °C). For best results, a vent system should be as short and straight as possible.

- This water heater is a Category IV appliance and must be vented accordingly with any 4" vent approved for use with Category III/IV or Special BH type gas vent.
- The manufacturer recommends the NovaVent line. However, the following are also UL listed manufacturers: ProTech Systems Inc. (FasNSeal), Metal-Fab Inc., and Heat-Fab Inc. (Saf-T Vent).
- Follow the vent pipe manufacturer’s instructions when installing the vent pipe.
- The maximum length of exhaust vent piping must not exceed 100 ft (30.5 m) (deducting 5 ft (1.5 m) for each elbow used in the venting system). Do not use more than 5 elbows.
- When the horizontal vent run exceeds 5 ft (1.5 m), support the vent run at 3 ft (0.9 m) intervals with overhead hangers.

STAINLESS STEEL ELBOW/LENGTH REQUIREMENTS

Table 12. Maximum Elbows for Vent Length

Diameter	Max. No. of Elbows	Max. Vertical and Horizontal (Total) Vent Length*
4 in. (102 mm)	5	100 ft (30.5 m)

*For each elbow added, deduct 5 ft. (1.5 m) from max. vent length

Table 13. Maximum Length Per Number of Elbows

No. of Elbows	Max. Vertical or Horizontal Vent Length	No. of Elbows	Max. Vertical or Horizontal Vent Length
0	100 ft (30.5 m)	3	85 ft (25.9 m)
1	95 ft (29.0 m)	4	80 ft (24.4 m)
2	90 ft (27.4 m)	5	75 ft (22.9 m)

Excludes vent terminators, termination elbows, or rain caps.

HOW TO INSTALL A STAINLESS STEEL DIRECT VENT

The following are typical installations using stainless steel vents:

Installing a Four-Inch Stainless-Steel Direct Vent Connection

1. Connect 4" (102 mm) stainless steel vent straight pipes directly on the exhaust/intake vent collar of the water heater.
2. Locate lower bank of DIP switches and set the appropriate switches for this configuration. See the appropriate settings below.

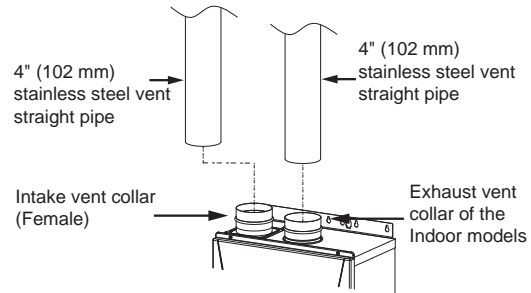

Figure 24. Four-Inch Stainless Steel Direct Vent Connection

Table 14. DIP Switch Settings for Two-Pipe Direct Vent Installations

5 to 50 ft (1.5 to 15.2m) (DEFAULT)	51 to 100 ft (15.3 to 30.5 m)
No. 3 : O N No. 4 : OFF	No. 3 : OFF No. 4 : OFF

WARNING

Breathing Hazard

- Adjust the appropriate DIP switches according to model and vent length as shown below. DO NOT adjust the other DIP switches.
- Turn off the power supply to the water heater before changing the DIP switch settings.
- Failure to observe these warnings could lead to carbon monoxide poisoning or death.

Breathing carbon monoxide can cause brain damage or death. Always read and understand the instruction manual.

Installing a Stainless-Steel Single Vent Connection

1. Connect a 4" (102 mm) stainless steel vent straight pipe directly on the exhaust vent collar of the water heater.
2. Connect a 4" (102 mm) elbow directly on the intake vent collar of the water heater.
3. Locate lower bank of DIP switches and set the appropriate switches for this configuration. See the appropriate settings below.

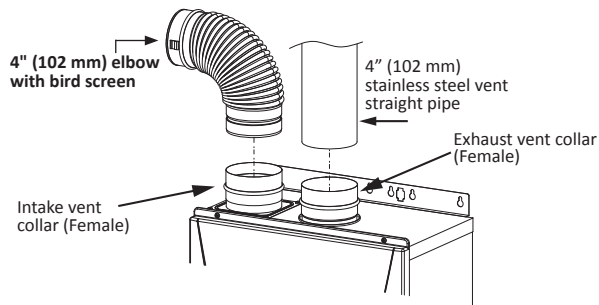

Figure 25. 4"Vent Connection for Single Vent Installation

Table 15. DIP switch settings : Single Pipe Direct Vent installations

4" (102 mm) Venting	
5 to 50 ft (1.5 to 15.2m) (DEFAULT)	51 to 100 ft (15.3 to 30.5 m)
No. 3 : O N No. 4 : OFF	No. 3 : OFF No. 4 : OFF

WARNING

Breathing Hazard

- Adjust the appropriate DIP switches according to model and vent length as shown below. DO NOT adjust the other DIP switches.
- Turn off the power supply to the water heater before changing the DIP switch settings.
- Failure to observe these warnings could lead to carbon monoxide poisoning or death.

Breathing carbon monoxide can cause brain damage or death. Always read and understand the instruction manual.

WARNING

Breathing Hazard

- Regarding the clearances from the exhaust terminal to the air inlet or opening, See **Termination Clearances for Sidewall Installations** (page 34) and **Clearances For Rooftop Terminations**(page 36).
- Follow all vent system manufacturer's instructions and all local codes.
- Use 4" (102 mm) Category III/IV approved or Special BH, single or double wall stainless steel vent pipe.
- Do not mix parts or fittings of different material types, and do not mix pipe, fittings, or joining methods from different manufacturers. Combustion exhaust can contain carbon monoxide and must be properly vented outside. Breathing abnormal amounts of carbon monoxide can result in serious injury or death.

Breathing carbon monoxide can cause brain damage or death. Always read and understand the instruction manual.

Approved Category IV, Single Wall, Venting Suppliers and Part Numbers			
Description	Heater Vent Kits	Z-FLEX®	
		Nova VENT™	Z-VENT™
4" (102 mm) Straight pipe - 6" (152 mm) length	100112407	2NVP4.5	2SVEPWCF0406
4" (102 mm) Straight pipe - 12" (305 mm) length	100112406	2NVP41	2SVEPWCF0401
4" (102 mm) Straight pipe - 24" (610 mm) length	100112404	2NVP42	2SVEPWCF0402
4" (102 mm) Straight pipe - 36" (914 mm) length	100112403	2NVP43	2SVEPWCF0403
4" (102 mm) Straight pipe - 48" (1,219 mm) length	100112402	2NVP44	2SVEPWCF0404
4" (102 mm) Adjustable straight pipe - 10"-18" (254 - 457 mm) adjustability	100112405	2NVAL4	2SVSPA04
4" (102 mm) 45 degree elbow	100112401	2NVE445	2SVEEWCF0445
4" (102 mm) 90 degree elbow	100112400	2NVE490	2SVEEWCF0490
4" (102 mm) Sidewall termination (4" (102 mm) Termination Hood)	100112419	2NVTH4	2SVSHTX04
4" (102 mm) Vent termination tee	100112547	2NVTT4	2SVSTTF04
4" (102 mm) Rain Cap	100112415	2NVRC4	2SVSRCF04
4" (102 mm) Extreme weather rain cap	100112548	2NVWC4	2SVSHRC04
4" (102 mm) Horizontal drain tee	100112414	2NVHD4	2SVEDWCF04
4" (102 mm) Vertical drain tee	100112413	2NVVD4	2SVEVDP04
4" (102 mm) wall thimble length 4"-7" (102 - 178 mm) wall thickness	100112732	2NVWT4	2SVSWTF04
4" (102 mm) wall thimble length 5"-10" (127 - 254 mm) wall thickness	100112733	2NVWT4L	2SVSWTEF04
4" (102 mm) 3-in-1 adaptor (F-F adaptor, condensate drain, & back-flow preventer)	100112585	2NVBFA4	2SVBFDPA04
4" (102 mm) F-F adaptor	100112399	2NVAFF4	2SVEEWCF0445
4" (102 mm) Backflow preventer w/ F-F adaptor	100112416	2NVBFU4	2ZVB04
4" (102 mm) exhaust / 3" (76 mm) intake DV concentric termination - 5"-10" (127 - 254 mm) adjustability	100112550	2NVHTC43S	2SVSHTC43S
4" (102 mm) exhaust / 3" (76 mm) intake DV concentric termination - 12"-18" (305 - 457 mm) adjustability	100112551	2NVHTC43	2SVSHTC43
4" (102 mm) Sidewall termination, adjustable pipe	100187853	2NVBV4	n/a
4" (102 mm) Wall Thimble, 3"-6" (76 - 152 mm) wall thickness	100187852	2NVBT4	n/a

Approved Category IV, Single Wall, Venting Suppliers and Part Numbers			
Description	Heater Vent Kits	Z-FLEX®	
		Nova VENT™	Z-VENT™
4" (102 mm) exhaust / 3" (76 mm) intake concentric termination - 5" to 10" (127 - 254 mm) adjustability	100112550	2NVHTC43S	2SVSHTC43S
4" (102 mm) exhaust / 3" (76 mm) intake concentric termination - 12" to 18" (305 - 457 mm) adjustability	100112551	2NVHTC43	2SVSHTC43
4" (102 mm) exhaust / 4" (102 mm) intake concentric termination - 5" to 10" (127 - 254 mm) adjustability	100112552	2NVHTC44S	2SVSHTC04S
4" (102 mm) exhaust / 4" (102 mm) intake concentric termination - 12" to 18" (305 - 457 mm) adjustability	100112553	2NVHTC44S	2SVSHTC04
4" (102 mm) Flat roof flashing	100112412	2NVFF4	2SVSSCF04
4" (102 mm) Angled roof flashing	100112411	2NVAF4	2SVSADJF04
Storm collar	100112410	2NVSC4	2SVSLSF04
Wall support	100112409	2NVSS41	2SVSWS04
Firestop support	100112408	2NVFS4	2SVSFSSF04

COMMON DIRECT VENTING REQUIREMENTS

The water heaters covered by this manual may be installed using a common direct vent kit. Contact your local distributor or call the parts department phone number listed on the back cover of this manual for more information or to order.

Installations must comply with applicable national, state, and local codes. For Canadian installation, polypropylene vent must be listed as a **ULC-S636** approved system. If polypropylene vent is not required by your local code, you may use either PVC or CPVC pipes for your water heater that allows non-metallic venting material installations.

Polypropylene vent systems do not use cement to connect the pipe and elbow sections but use a push together gasket seal method. Do not attempt to connect polypropylene with sealant cement. All vent connections **MUST** be secured by the vent manufacturer's joint connector. The installer must use a specific vent starter adapter at the flue connection. The adapter is supplied by the vent manufacturer to adapt to its vent system.

In order to be in full compliance with **UL 1738** or **ULC-S636** and to meet the requirements of the water heater manufacturer, you must use the metal joint connector rings, available from the polypropylene vent manufacturer, to stiffen the joints of two-inch, three-inch, and four-inch diameter pipes.

COMMON DIRECT-VENTING SYSTEM

The water heater can be vented together with other water heaters using the same exhaust and intake venting.

Up to 8 water heaters can be common-vented together.

A non-return valve (100113130) must be used for each water heater that is part of the system.

The water heaters must all be direct-vented.

The common-venting system shall be in accordance with the **National Fuel Gas Code, ANSI Z223.1/NFPA 54** and/or **B149.1, Natural Gas and Propane Installation Code (Current Editions)**, local codes, and the following manufacturer's instructions.

! WARNING

Breathing Hazard



Only the (A/S/M) TX-199 models can be common-vented together. Different models cannot be common-vented.

Failure to observe these warnings could lead to carbon monoxide poisoning or death.

Breathing carbon monoxide can cause brain damage or death. Always read and understand the instruction manual.

TYPICAL COMMON VENT SYSTEM CONFIGURATIONS

For common-venting pieces and components, the manufacturer recommends Centrotherm's vent line. The following are some typical common vent configurations:

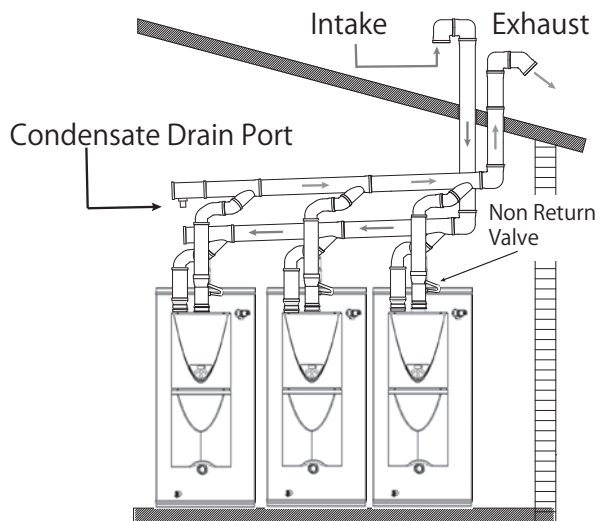

Figure 26. Common Vent, Vertical Intake, Vertical Vent

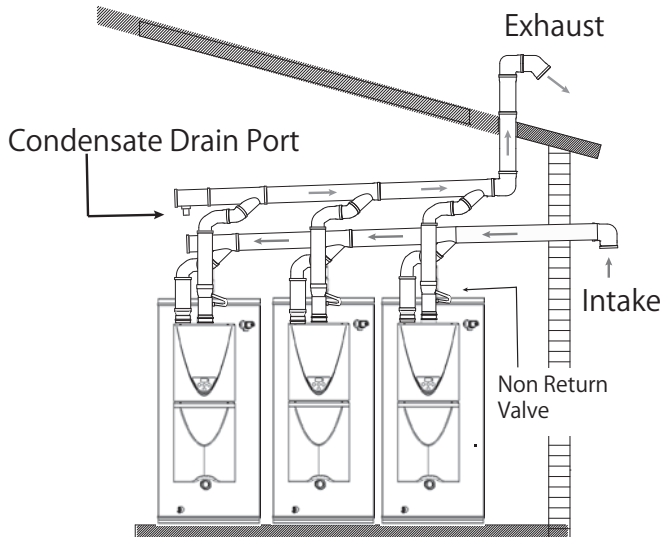

Figure 27. Common Vent, Horizontal Intake, Vertical Vent

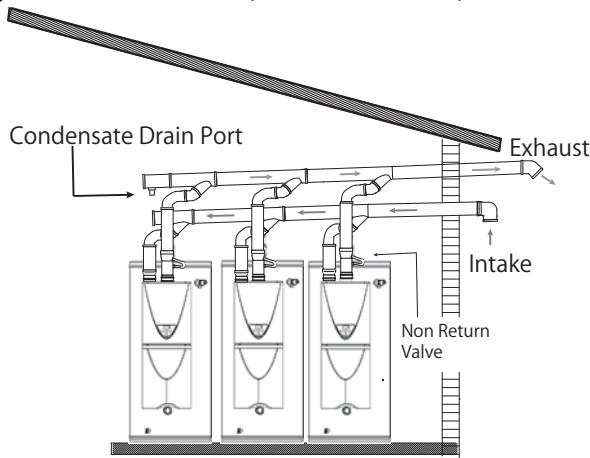

Figure 28. Common Vent, Horizontal Intake, Horizontal Vent

For details on the installation of a common-venting system, please refer to "Common Venting Gas Water Heaters." It is a manual which is available on the water heater manufacturer's website.

DETERMINING COMMON VENT SYSTEM DIMENSIONS

Determine the vent diameter (D) and the total vent length based on the number of water heaters installed. The total vent length (L) consists of the horizontal width (W) and the vertical height (H). See **Table 16** (page 28).

- Total vent length (L) = "H" + "W"
- Vent diameter = "D"

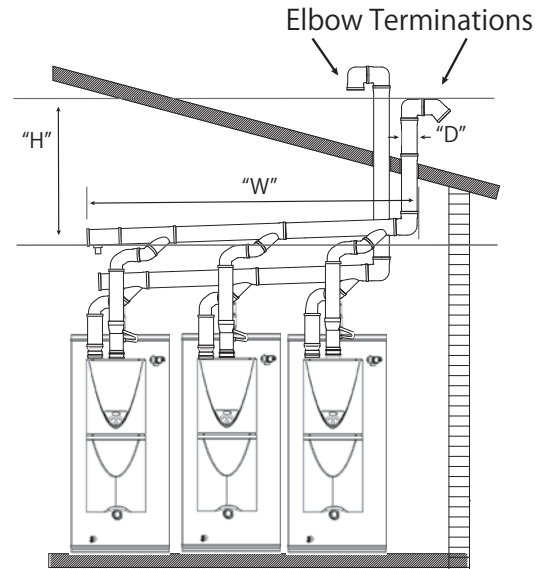

Figure 29. Common Vent System Dimensions

NOTE: Regarding the clearances between the exhaust termination and the intake termination, refer to **Table 18** (page 34).

NOTE: Insert bird screen in elbow terminations

		WARNING
	Breathing Hazard	
<p>Where multiple appliances have a common vent configuration, a non-operating appliance can draw combustion gasses, including carbon monoxide, into the living space unless a non-return valve is installed as directed.</p>		

For detailed instructions on the common-venting system, refer to the instructions that are packaged with the vent parts or web site.

Table 16. Common-Venting System DIP Switch Settings

Vent Diameter* (D)	Max. No. of Water Heaters	Max. Vertical and Horizontal (Total) Vent Length** (L)	DIP Switch Settings
4 in. (110 mm)	2	25 ft (7.6 m)	(Upper bank DIP switches) ON  OFF No.3 : ON / No.4: OFF
5 in. (125 mm)	2	50 ft (15.2 m)	
	3	20 ft (6.1 m)	
6 in. (160 mm)	2	100 ft (30.5 m)	
	3	75 ft (22.9 m)	
	4	50 ft (15.2 m)	
	5	25 ft (7.6 m)	
8 in. (200 mm)	6	20 ft (6.1 m)	
	3	100 ft (30.5 m)	
	4	100 ft (30.5 m)	
	5	85 ft (25.9 m)	
10 in. (250 mm)	6	65 ft (19.8 m)	
	7	50 ft (15.2 m)	
	8	41 ft (12.5 m)	
	5	100 ft (30.5 m)	
10 in. (250 mm)	6	100 ft (30.5 m)	
	7	100 ft (30.5 m)	
	8	100 ft (30.5 m)	
	8	100 ft (30.5 m)	

*Diameters of pipes are in accordance with Centrotherm's specifications.
 **One elbow is equivalent to 5 ft (1.5 m) linear length, and the maximum number of elbows is 5.

CONCENTRIC TERMINATION INSTALLATION PREPARATION

1. Concentric terminations must be ordered separately. Contact your local distributor or call the parts department phone number on the back cover of this manual to order concentric terminations.
2. Determine the location for the termination.
NOTE: Roof termination is preferred since it is less susceptible to damage, has reduced chances to intake contaminants, and vent vapors are less visible.
3. When installing a concentric termination vertically through the roof; ensure that all exterior vertical clearance requirements for the concentric termination, shown in **Figure 32** (page 29), are being maintained. These clearances and those cited by local and national codes must be maintained.
4. When installing a concentric termination vertically through a flat roof, the termination's vent cap must be a minimum of 10 feet (3 m) away from any parapet, vertical wall or structure, as shown in **Figure 30** (page 28).

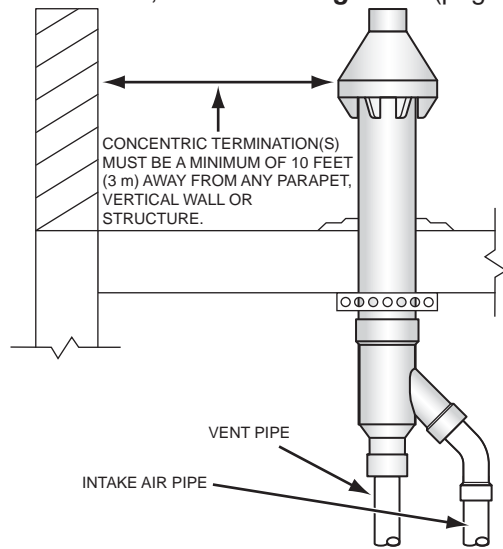



Figure 30. Concentric Termination - Flat Roof Clearance

NOTE: If this required 10 foot (3 m) distance to a parapet, vertical wall, or structure cannot be maintained, standard terminations must be used.

5. When installing a concentric termination through a sidewall, ensure that all exterior sidewall clearance requirements for the termination, shown in **Figure 35** (page 34), are being maintained. These clearances and those cited by local and national codes must be maintained.
6. Cut a seven-inch (18 cm) diameter hole for the six-inch concentric terminal where the termination will pass through the wall or roof.
NOTE: Beware of concealed wiring and piping when cutting through the wall or roof.
7. Determine if the concentric termination will need to be shortened to accommodate required clearances or to ensure all vent caps are at the same height when installing multiple terminations vertically through the roof in the same location.
 - See **Figure 31** (page 29) for the minimum lengths allowed for the concentric termination.



WARNING

Breathing Hazard



- Turn off the power supply to the water heater before changing the DIP switch settings.
- Adjust the appropriate DIP switches according to model as shown. DO NOT adjust the other DIP switches.
- (See **Figure 34** (page 33) for the location of the DIP switches.)
- Failure to observe these warnings could lead to carbon monoxide poisoning or death.

Breathing carbon monoxide can cause brain damage and death. Always read and understand the instruction manual

- **NOTE:** When shortening the length of the termination, carefully measure and cut the larger (intake air) pipe first. Cut the same amount of pipe from the smaller (vent) pipe.
 - **NOTE:** Lengthening of the Concentric Vent Termination is not permitted.
8. Proceed to **Concentric Termination Installation** (page 29).

CONCENTRIC TERMINATION INSTALLATION

Assemble and install the four-inch concentric termination. Refer to **Figure 31**, **Figure 32**, and **Figure 33** for these instructions:

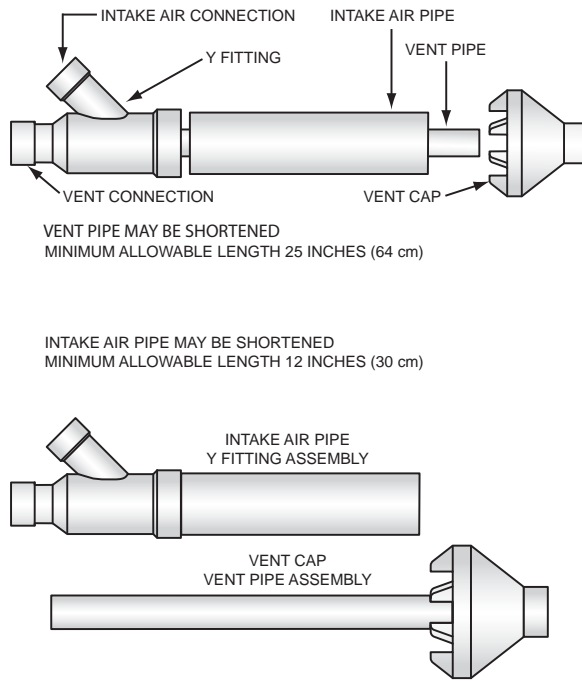

Figure 31. Concentric Termination Kit

1. Cement the Y fitting to the larger diameter intake air pipe.
2. Slide the intake air pipe and Y fitting assembly from inside the building through the hole cut for the termination in the roof or sidewall. Ensure no foreign materials such as insulation accumulate inside the assembly.
3. Secure the intake air Y fitting assembly using field supplied metal strapping or equivalent support materials.
4. On installations installed through the roof, slide a field-supplied plumbing boot or roof flashing over the intake air Y-fitting assembly and secure it to the roof.
5. Seal around the plumbing boot or roof flashing.
6. Cement the vent cap onto the vent pipe. Alternately a field-supplied stainless steel screw may be used to secure the two components together when field disassembly is desired for cleaning. A pilot hole must be drilled for the screw to prevent damage/cracking of the vent cap and/or vent pipe.

7. Install the vent cap/vent pipe assembly into the intake air Y fitting assembly. Ensure the small diameter vent pipe is cemented and bottomed in the Y fitting. Do not exceed the maximum equivalent vent length listed in **Table 7** (page 21).
8. Cement all fittings and pipe in place.
9. Return to **Direct Vent Installations** (page 22) to complete the installation of the intake air and vent piping between the concentric termination and the water heater.

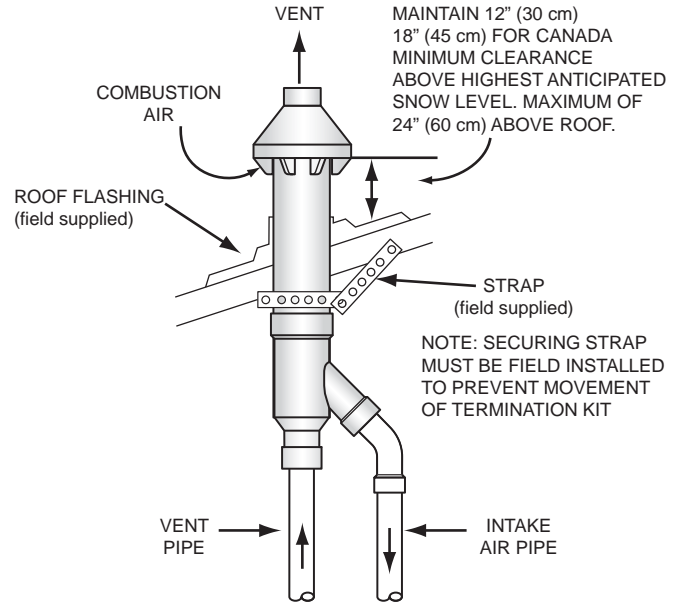

Figure 32. Concentric Termination - Vertical Installation

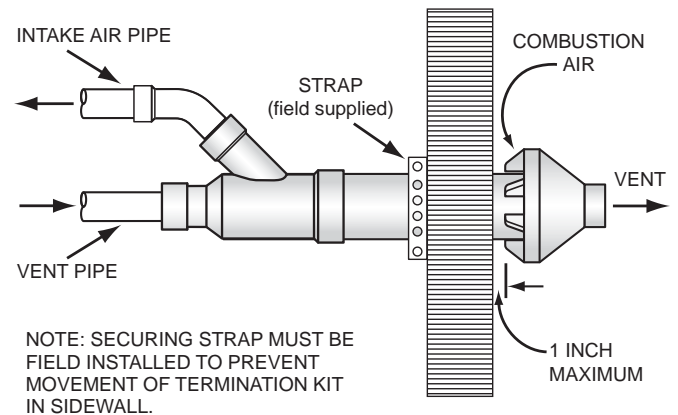
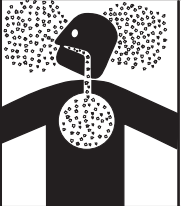

Figure 33. Concentric Termination - Side-Wall Installation

CONTAMINATED AIR

Corrosion of the flue ways and vent system may occur if air for combustion contains certain chemical vapors. Such corrosion may result in failure and risk of asphyxiation.

Combustion air that is contaminated can greatly diminish the life span of the water heater and water heater components such as igniters and burners. Propellants of aerosol sprays, beauty shop supplies, water softener chemicals and chemicals used in dry cleaning processes that are present in the combustion, ventilation or ambient air can cause such damage.

⚠ WARNING	
Breathing Hazard - Carbon Monoxide Gas	
	<ul style="list-style-type: none">• Install water heater in accordance with the Instruction Manual and NFPA 54 or CAN/CSA-B149.1.• To avoid injury, combustion and ventilation air must be taken from outdoors.• Do not place chemical vapor emitting products near water heater.
Breathing carbon monoxide can cause brain damage or death. Always read and understand instruction manual.	

Do not store products of this sort near the water heater. Air which is brought in contact with the water heater should not contain any of these chemicals. If necessary, uncontaminated air should be obtained from remote or outdoor sources. The limited warranty is voided if the water heater fails due to a corrosive atmosphere. See the Commercial Integrated Tankless on Tank Limited Warranty provided with this water heater.

If the water heater will be used in beauty shops, barber shops, cleaning establishments, or self-service laundries with dry cleaning equipment, it is imperative that the water heater(s) be installed in a **direct vent** configuration so that all air for combustion comes directly from the outdoor atmosphere through a sealed intake air pipe. See **Direct Vent Installations** (page 22).

AIR REQUIREMENTS

For safe operation, an adequate supply of fresh uncontaminated air for combustion and ventilation must be provided.

An insufficient supply of air can cause recirculation of combustion products resulting in contamination that may be hazardous to life. Such a condition often will result in a yellow, luminous burner flame, causing sooting of the combustion chamber, burners and flue tubes, and creates a risk of asphyxiation.

⚠ WARNING	
Breathing Hazard - Carbon Monoxide Gas	
	<ul style="list-style-type: none">• Install water heater in accordance with the Instruction Manual and NFPA 54 or CAN/CSA-B149.1.• To avoid injury, combustion and ventilation air must be taken from outdoors.• Do not place chemical vapor emitting products near water heater.
Breathing carbon monoxide can cause brain damage or death. Always read and understand instruction manual.	

Do not install the water heater in a confined space unless an adequate supply of air for combustion and ventilation is brought in to that space using the methods described in **Confined Space** (page 30).

Never obstruct the flow of ventilation air. If you have any doubts or questions at all, call your gas supplier. Failure to provide the proper amount of combustion air can result in a fire or explosion and cause property damage, serious bodily injury, or death.

UNCONFINED SPACE

An **unconfined space** is one in which the volume IS NOT LESS THAN 50 cubic feet per 1,000 Btu/hr (4.8 cubic meters per kW) of the total input rating of all appliances installed in the space. Rooms communicating directly with the space in which the appliances are installed, through openings not furnished with doors, are considered a part of the unconfined space.

Makeup air requirements for the operation of exhaust fans, kitchen ventilation systems, clothes dryers and fireplaces shall also be considered in determining the adequacy of a space to provide combustion, ventilation and dilution air.

UNUSUALLY TIGHT CONSTRUCTION

In unconfined spaces in buildings, infiltration may be adequate to provide air for combustion, ventilation, and dilution of flue gases. However, in buildings of unusually tight construction (for example, weather stripping, heavily insulated, caulked, vapor barrier, etc.), additional air must be provided using the methods described in the **Confined Space** (page 30) section that follows.

CONFINED SPACE

A **confined space** is one in which the volume is **less than** 50 cubic feet per 1,000 Btu/hr (4.8 cm per kW) of the total input rating of all appliances installed in the space.

OPENINGS MUST BE INSTALLED TO PROVIDE FRESH AIR FOR COMBUSTION, VENTILATION, AND DILUTION IN CONFINED SPACES. THE REQUIRED SIZE FOR THE OPENINGS DEPENDS ON THE METHOD USED TO PROVIDE FRESH AIR TO THE CONFINED SPACE AND THE TOTAL BTU/HR INPUT RATING OF ALL APPLIANCES INSTALLED IN THE SPACE. DIRECT

VENT APPLIANCES

Appliances installed in a direct vent configuration that get all air for combustion from the outdoor atmosphere through sealed intake air piping do not factor into the total appliance input Btu/hr calculations that determine the size of openings required to provide fresh air in confined spaces.

EXHAUST FANS

Where exhaust fans are installed, additional air shall be provided to replace the exhausted air. When an exhaust fan is installed in the same space with a water heater, sufficient openings to provide fresh air must be provided that accommodate the requirements for all appliances in the room and the exhaust fan. Undersized openings cause air to be drawn into the room through the water heater's vent system causing poor combustion. Sooting, serious damage to the water heater, and the risk of fire or explosion may result. It can also create a risk of asphyxiation.

LOUVERS AND GRILLES

The free areas of the fresh air openings in the instructions that follow do not take in to account the presence of louvers, grilles or screens in the openings.

The required size of openings for combustion, ventilation and dilution air shall be based on the "net free area" of each opening. Where the free area through a design of louver or grille or screen is known, it shall be used in calculating the size of opening required to provide the free area specified. Where the louver and grille design and free area are not known, it shall be assumed that wood louvers will have 25% free area and metal louvers and grilles will have 75% free area. Non motorized louvers and grilles shall be fixed in the open position.

For examples of configurations that can be used to ensure an adequate combustion air supply, see ***Combustion Air Supply Options*** (page 20).

INSTALLATION REQUIREMENTS - COMMONWEALTH OF MASSACHUSETTS

For all side wall terminated, horizontally vented power vent, direct vent, and power direct vent gas fueled water heaters installed in every dwelling, building or structure used in whole or in part for residential purposes, including those owned or operated by the Commonwealth and where the side wall exhaust vent termination is less than seven (7) feet above finished grade in the area of the venting, including but not limited to decks and porches, the following requirements shall be satisfied:

INSTALLING CARBON MONOXIDE DETECTORS

At the time of installation of the side-wall horizontal-vented gas-fueled equipment, the installing plumber or gas-fitter shall observe that a hard-wired carbon-monoxide detector, with an alarm and battery back-up, is installed on the floor level where the gas equipment is to be installed. In addition, the installing plumber or gas-fitter shall observe that a battery-operated or hard-wired carbon-monoxide detector, with an alarm, is installed on each additional level of the dwelling, building, or structure served by the side-wall horizontal-vented gas-fueled equipment. It shall be the responsibility of the property owner to secure the services of qualified licensed professionals for the installation of hard-wired carbon-monoxide detectors.

In the event that the side-wall horizontally-vented gas-fueled equipment is installed in a crawl space or an attic, the hard-wired carbon-monoxide detector, with alarm and battery back-up, may be installed on the next adjacent floor level.

In the event that the requirements of this subdivision can not be met at the time of completion of installation, the owner shall have a period of thirty (30) days to comply with the above requirements provided that during said thirty (30) day period, a battery-operated carbon-monoxide detector, with an alarm, shall be installed.

APPROVED CARBON MONOXIDE DETECTORS

Each carbon-monoxide detector as required in accordance with the above provisions shall comply with **NFPA 720** and be **ANSI/UL 2034** listed and **CSA** certified.

SIGNAGE

A metal or plastic identification plate shall be permanently mounted to the exterior of the building at a minimum height of eight (8) feet above grade directly in line with the exhaust vent terminal for the horizontally-vented gas-fueled heating appliance or equipment. The sign shall read, in print size no less than one-half (1/2) inch in size, "**GAS VENT DIRECTLY BELOW. KEEP CLEAR OF ALL OBSTRUCTIONS.**"

INSPECTION

The state or local gas inspector of the side-wall horizontally-vented gas-fueled equipment shall not approve the installation unless, upon inspection, the inspector observes

carbon-monoxide detectors and signage installed in accordance with the provisions of **248 CMR 5.08(2)(a) 1 through 4**.

EXEMPTIONS

The following equipment is exempt from **248 CMR 5.08(2)(a)1 through 4**:

1. The equipment listed in Chapter 10 entitled "Equipment Not Required To Be Vented" in the most current edition of **NFPA 54** as adopted by the Board; and
2. Product Approved side-wall horizontally-vented gas-fueled equipment installed in a room or structure separate from the dwelling, building, or structure used in whole or in part for residential purposes.

MANUFACTURER REQUIREMENTS - GAS EQUIPMENT VENTING SYSTEM PROVIDED

When the manufacturer of Product Approved side-wall horizontally-vented gas-fueled equipment provides a venting system design or venting system components with the equipment, the instructions provided by the manufacturer for installation of the equipment and the venting system shall include:

1. Detailed instructions for the installation of the venting-system design or the venting-system components
2. A complete parts list for the venting-system design or venting system.

MANUFACTURER REQUIREMENTS - GAS EQUIPMENT VENTING SYSTEM NOT PROVIDED

When the manufacturer of a Product Approved side-wall horizontally-vented gas-fueled equipment does not provide the parts for venting the flue gases, but identifies "special venting systems," the following requirements shall be satisfied by the manufacturer:

1. The referenced "special venting system" instructions shall be included with the appliance or equipment installation instructions.
2. The "special venting systems" shall be Product Approved by the Board, and the instructions for that system shall include a parts list and detailed installation instructions.

A copy of all installation instructions for all Product Approved side-wall horizontally-vented gas-fueled equipment, all venting instructions, all parts lists for venting instructions, and/or all venting-design instructions shall remain with the appliance or equipment at the completion of the installation.

HIGH-ALTITUDE INSTALLATIONS

If the water heater is installed at a location with an elevation above 2000 feet (611 m), proper operation requires the adjustment of the combustion parameters. These parameters correspond to lower-bank DIP switches on the computer board.

Do the following to adjust the water heater for high-altitudes:

1. Check the elevation where your water heater is installed. Find your altitude in **Table 17**.
2. Disconnect power supply from the water heater.
3. Take off the water heater's upper front cover.
4. Locate the computer board in the unit case. See **Figure 3** (page 8).
5. Remove the computer board cover.
6. Locate the lower bank DIP switches on the computer board.

WARNING

Fire and Explosion Hazard

- Under no circumstances should the input exceed the rate shown on the water heater's rating label.
- Overfiring could result in fire or explosion.
- Gas and carbon monoxide detectors are available.

WARNING

Breathing Hazard - Carbon Monoxide Gas

- Under no circumstances should the input exceed the rate shown on the water heater's rating label.
- Overfiring could result in damage to the water heater and sooting.
- Gas and carbon monoxide detectors are available.

Breathing carbon monoxide can cause brain damage or death. Always read and understand instruction manual.

- **Warning:** Turn off the power supply to the water heater before changing the DIP switch settings.
- **Warning:** Failure to observe these warnings could lead to carbon monoxide poisoning or death.

WARNING

Shock or Breathing Hazard

- Turn off the power supply to the water heater before changing the DIP switch settings.
- Failure to observe these warnings could lead to carbon monoxide poisoning or death.

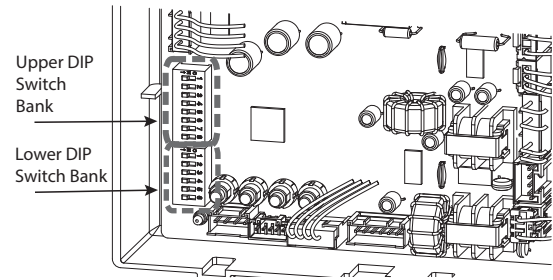

Figure 34. Location of DIP Switches

7. On the lower DIP switch bank, note the position of DIP switches 2, 3, and 4.

Table 17 shows the DIP switch settings for the range of altitudes. The DIP switches are the lower bank DIP switches.

Table 17. High Altitude DIP Switch Settings		
Altitude	DIP Switch Settings	
0 to 2,000 ft (0 to 610 m) (DEFAULT)	ON OFF	No. 2 : OFF No. 3 : OFF No. 4 : OFF
2,000 to 3,000 ft (611 to 914 m)	ON OFF	No. 2 : OFF No. 3 : ON No. 4 : OFF
3,000 to 5,000 ft (915 to 1,524 m)	ON OFF	No. 2 : OFF No. 3 : OFF No. 4 : ON
5,000 to 7,500 ft (1,525 to 2,286 m)	ON OFF	No. 2 : OFF No. 3 : ON No. 4 : ON
7,500 to 10,100 ft (2,287 to 3,078 m)	ON OFF	No. 2 : ON No. 3 : ON No. 4 : ON

NOTE: The dark squares indicate the correct DIP switch positions.

Maximum Certified or Allowable Installed Altitude: 10,100 ft (3,078 m)

TERMINATION CLEARANCES FOR SIDEWALL INSTALLATIONS

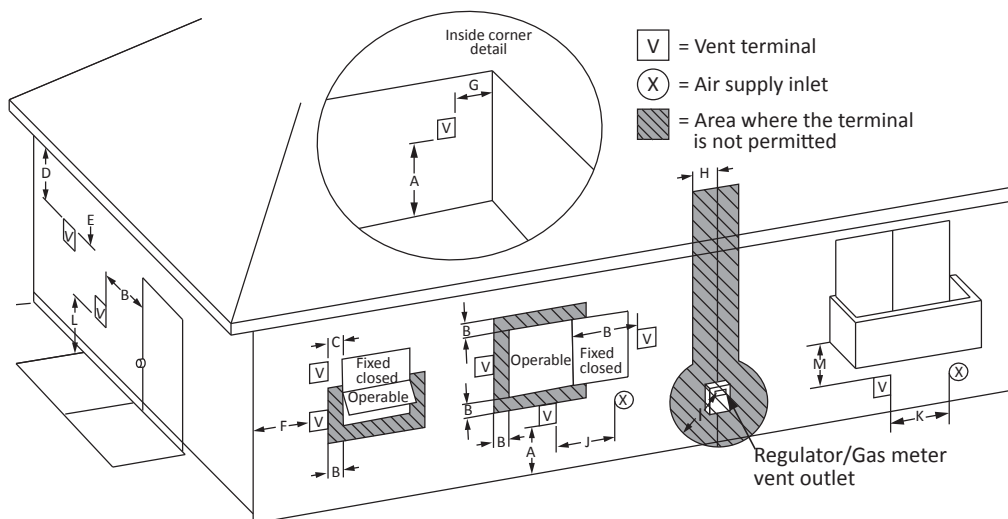

Figure 35. Vent Termination Clearances

Table 18. Vent Termination Clearances for Direct Vent and Other Vent Systems

		Canada Installations ¹	US Installations ²	
		Direct Vent/Other Than Direct Vent	Direct vent	Other Than Direct Vent
A	Clearance above grade, veranda, porch, deck, or balcony	1 ft (30 cm)	1 ft (30 cm)	
B	Clearance to window or door that may be opened	3 ft (91 cm)	1 ft (30 cm)	4 ft (1.2 m) below or to side of opening; 1 ft (30 cm) above opening
C	Clearance to permanently closed window	0	0	0
D	Vertical clearance to ventilated soffit located above the vent terminator within a horizontal distance of 2 feet (61cm) from the center line of the termination	3 ft (91 cm)	3 ft (91 cm)	3 ft (91 cm)
E	Clearance to unventilated soffit	3 ft (91 cm)	3 ft (91 cm)	3 ft (91 cm)
F	Clearance to outside corner	2 ft (61 cm)	2 ft (61 cm)	2 ft (61 cm)
G	Clearance to inside corner	2 ft (61 cm)	2 ft (61 cm)	2 ft (61 cm)
H	Clearance to each side of center line extended above meter/regulator assembly	3 ft (91 cm)	*	*
I	Clearance to service regulator vent outlet	Above a regulator within 3 ft (91 cm) horizontally of the vertical center line of the regulator vent outlet to a maximum vertical distance of 15 ft (4.5 m)	*	*
J	Clearance to non-mechanical air supply inlet to building or the combustion air inlet to any other appliance.	3 ft (91 cm)	1 ft (30 cm)	4 ft (1.2 m) below or to side of opening; 1 ft (30 cm) above opening
K	Clearance to mechanical air supply inlet	6 ft (183 cm)	3 ft (91 cm) above if within 10 ft (3 m) horizontally.	
L	Clearance above paved sidewalk or paved driveway located on public property	7 ft (213 cm)**	7 ft (213 cm)	7 ft (213 cm)
M	Clearance under veranda, porch deck, or balcony	1 ft (30 cm)***	1 ft (30 cm)***	1 ft (30 cm)***

*Clearance in accordance with local installation codes and the requirements of the gas supplier.

**A vent shall not terminate directly above a sidewalk or paved driveway that is located between two single family dwellings and serves both dwellings.

***Permitted only if veranda, porch, deck, or balcony is fully open on a minimum of two sides beneath the floor.

The vent for condensing water heaters shall not terminate:

- 1) Over public walkways; or
- 2) Near soffit vents or crawl space vents or other areas where condensate or vapor could create a nuisance or hazard or cause property damage; or
- 3) Where condensate vapor could cause damage or could be detrimental to the operation of regulators, relief valves, or other equipment.

Notes:

1) In accordance with the current **CSA B149.1, Natural Gas and Propane Installation Code**

2) In accordance with the current **ANSI Z223.1/NFPA 54, National Fuel Gas Code**

! WARNING

Breathing Hazard



Improper installation can result in carbon monoxide poisoning or death. Follow all local and national codes in regards to proper termination clearances. In the absence of such codes, the clearances below can be used as guidelines. Local codes supersede these guidelines.

Breathing carbon monoxide can cause brain damage or death. Always read and understand the instruction manual.

Multiple Sidewall Terminations

An exhaust termination must be at least 1 ft (305 mm) away from another exhaust termination. An exhaust termination must also be at least 2 ft (610 mm) away from an inside corner. (If the adjacent wall is less than 2 ft (610 mm) of length, the minimum required distance away from the inside corner will be equal to the length of that adjacent wall.)

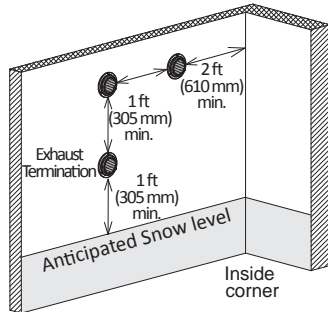

Multiple DV Sidewall Terminations

A direct vent (DV) termination must be at least 1 ft (305 mm) away from other direct vent terminations.

A direct vent termination must also be at least 2 ft (610 mm) away from an inside corner. (If the adjacent wall is less than 2 ft (610 mm) of length, the minimum required distance away from the inside corner will be equal to the length of that adjacent wall.)

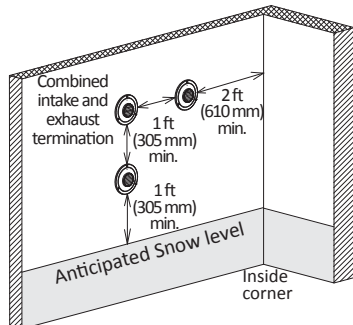

Adjacent Buildings

Exhaust and/or direct vent sidewall terminations should be at least 2 ft (610 mm) away from an opposite surface/wall. Do not place the termination directly in front of an opening into a building.

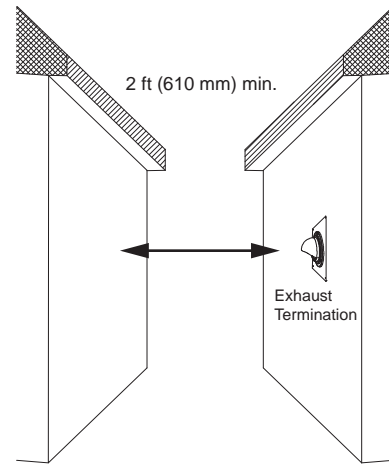
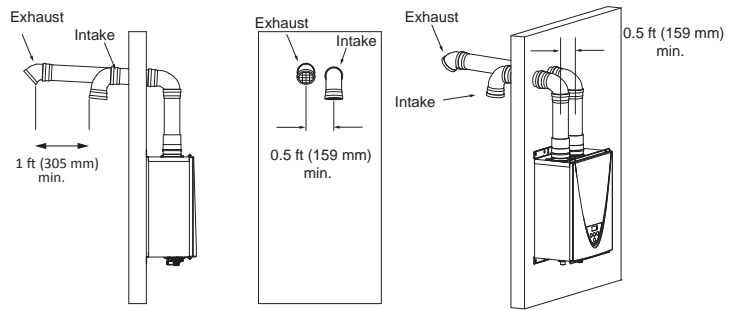

Figure 36. Clearance From Adjacent Buildings

Case 1: Long Terminations

For direct vent sidewall terminations that use two separate penetrations for the intake and exhaust, keep the termination clearances shown in the diagrams.



Case 2: Shorter Terminations

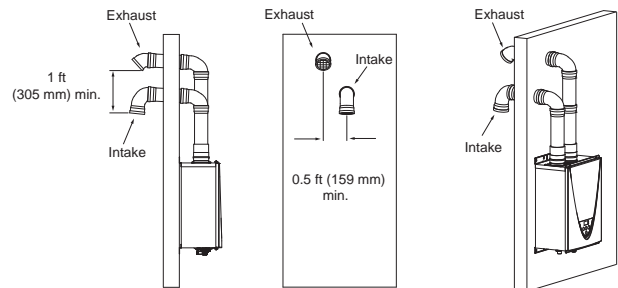

CLEARANCES FOR ROOFTOP TERMINATIONS

! WARNING	
Breathing Hazard	
	<p>Follow all local and national codes in regards to proper termination clearances. In the absence of such codes, the clearances below must be met. Local codes supersede these clearances. Failure to observe this warning may result in severe personal injury or death.</p>
	<p>Breathing carbon monoxide can cause brain damage or death. Always read and understand the instruction manual.</p>

Note: Canadian requirements differ from the guidelines in this section. In Canada, follow the requirements of B149.1 (Natural Gas and Propane Installation Code, current edition) as well as local and provincial codes. Contact your local code enforcement agency for direction.

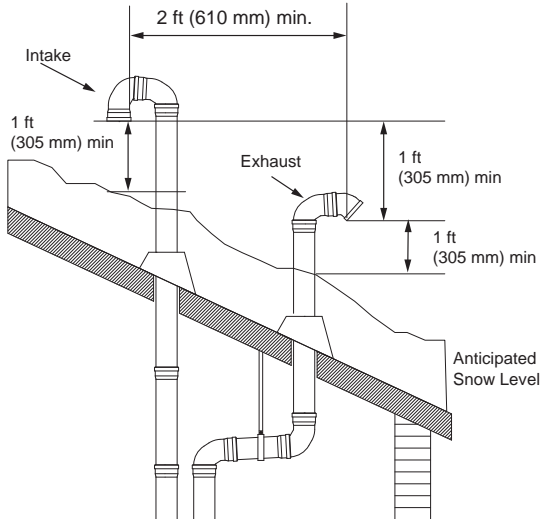

Figure 37. Angled Roof Termination

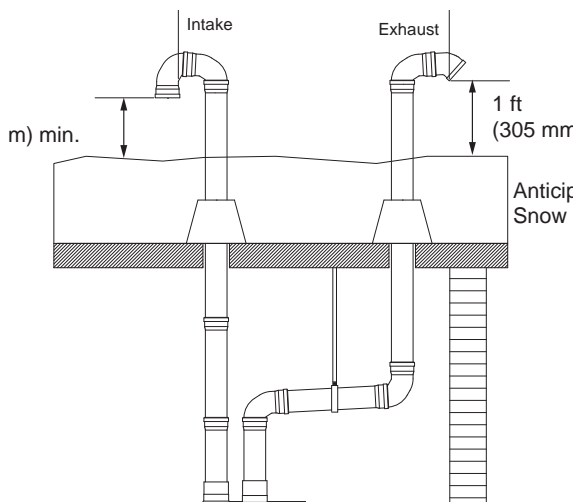

Figure 38. Flat Roof Termination

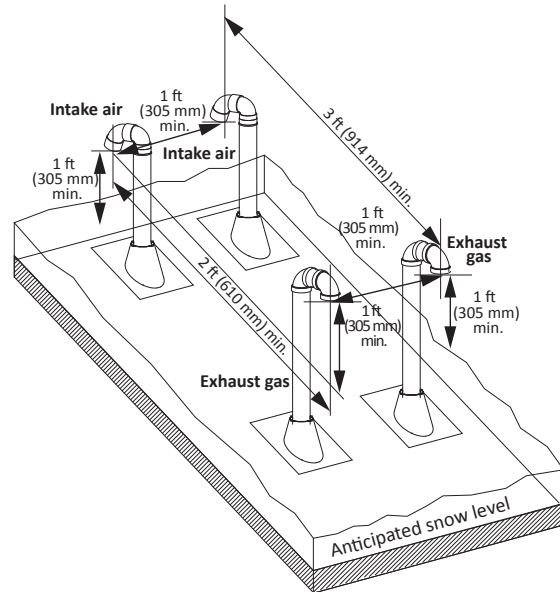

Figure 39. Multiple Angled Roof Terminations

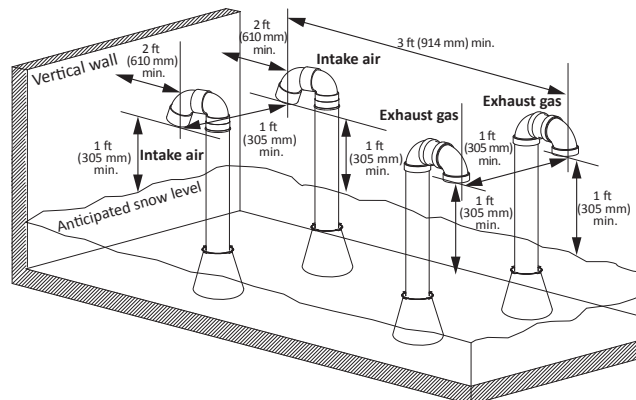



Figure 40. Multiple Flat Roof Terminations

! WARNING	
Breathing Hazard	
	<ul style="list-style-type: none"> Exhaust terminations must be at least 1 ft (305 mm) away from any obstructions. Minimum spacing between multiple terminals: <ul style="list-style-type: none"> Intake terminals: 1 ft (305 mm) spacing between each Exhaust terminals: 1 ft (305 mm) spacing between each The exhaust termination must be a horizontal distance of at least 2 ft (610 mm) from a wall or surface unless specified differently by local code. Failure to observe this warning may result in severe personal injury or death.
	<p>Breathing carbon monoxide can cause brain damage or death. Always read and understand the instruction manual.</p>

WATER HEATER INSTALLATION

WATER HEATING UNIT CONDENSATE DRAIN

Condensate can accumulate within the water heating unit.

In the absence of applicable local codes and regulations, the manufacturer recommends that condensate be disposed of into a drain. Connect a drain tube from the condensate drain port located on the bottom of the water heater to a standard drain. See **Figure 43** (page 38).

The condensate that accumulates from the water heating unit can be acidic. Local codes and regulations might require that the condensate be neutralized before being discharged into a drain. If required by local codes and regulations, an accessory neutralizer assembly (100112159/TH-NT01) is available for purchase separately. See **Figure 43** (page 38).

Installation of the condensate drain must conform with these instructions and local building codes.

Follow these instructions and all code requirements of the local authority for condensate neutralizers, whether or not they are required for the installation.

INSTALLATION NOTES

- Discharge condensate (acidic water) in accordance with all local codes and common safety practices.
- Use corrosion resistant pipe, such as PVC, for the condensate drain line.
- Do not use metal pipe.
- The condensate drain does not require a trap.
- Maintain a downward slope on the drain line(s), including installations in which the drain is not directly below the water heater.
- A field-supplied bypass is required if a neutralizer is installed.
- Do not connect the condensate drain line directly to a condensate pump.
- If the drain line is required to have bends, ensure that there are no kinks that will restrict the flow of condensation.
- The condensate drain is at atmospheric pressure (non-pressurized) and therefore must be allowed to drain freely with gravity only. Ensure that the condensate drain tube is not plugged or blocked, and ensure that it slopes downward to allow condensate to flow freely. All portions of the condensate drain (neutralizer and drain tube) must be at a lower elevation than the water heater to prevent condensate water from building up inside the water heating unit.

- Condensate cannot be effectively neutralized if the neutralizer elements inside the Neutralizer accessory have been completely consumed. If this happens, condensate will remain acidic and can possibly cause damage to items such as pipes, concrete, etc., if drained improperly.
- The actual life of the neutralizer may vary, depending on the application and usage. Replace the cartridge when the condensate pH goes below 6.0.
- Please ensure that the cartridge is properly replaced before the neutralizer elements have been completely consumed.
- All preventative measures and safety practices must be adhered to when draining condensate. The manufacturer will not be responsible for any damage caused by condensate.
- A drain pan, or other means of protection against water damage, is recommended to be installed under the water heater in case of leaks.

CONDENSATE DRAIN INSTALLATION INSTRUCTIONS

The water heater is a high efficiency condensing water heater that produces condensate (acidic water). The acidic condensate generated in the secondary heat exchanger can be neutralized by the neutralizer accessory (100112159/TH-NT01).

Although a neutralizer is not required, a condensate drain must be installed as described on the next page.

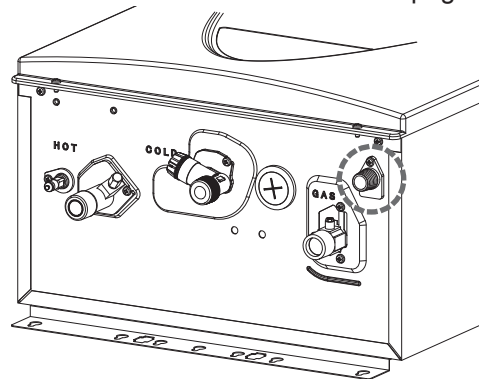

Figure 41. Water Heating Unit Condensate Drain Port

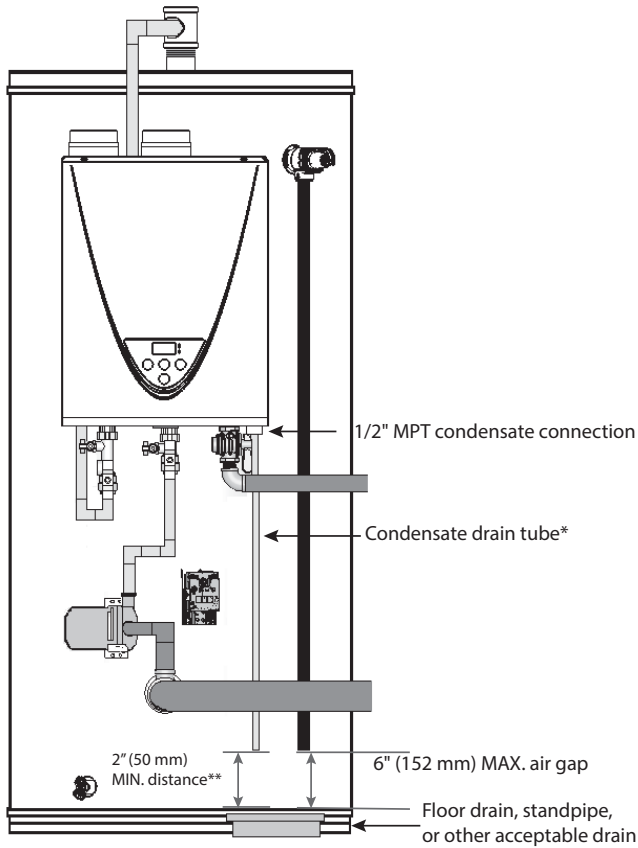

Figure 42. 1/2" Drain Tube Installed

*Maintain downward slope, including installations in which the drain is not directly below the heater.

**A two-inch (50 mm) air gap must be maintained between the condensate line and drain to allow full flow of the condensation.

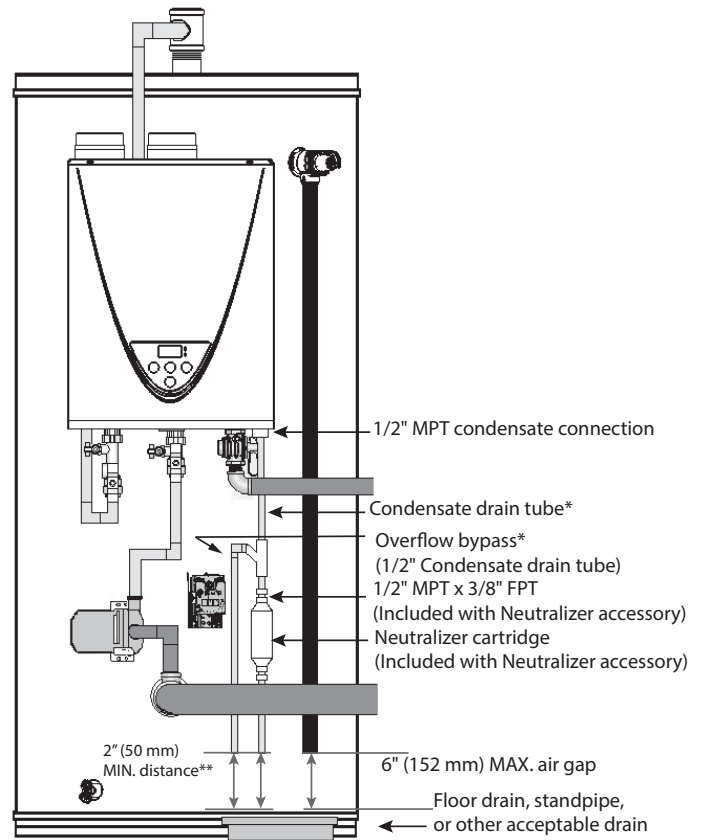

Figure 43. 1/2" Drain Tube/Neutralizer Cartridge Installed

*Maintain downward slope, including installations in which the drain is not directly below the heater.

**A two-inch (50 mm) air gap must be maintained between the condensate line and drain to allow full flow of the condensation.

INSTALLATION NOTES

1. The condensate drains from the water heater's covered by this instruction have PH levels between 4.3 and 5.0. Install a commercially available neutralizing kit if required by local codes. Lower PH levels are acidic. Do not connect a metal condensate drain line, such as copper pipe, to the water heater for this reason.
2. The field installed condensate drain line must not be less than 1/2 inch PVC in size.
3. Install a proper drip leg.

SUPPLY GAS LINE INSTALLATION

Contact your local gas utility company to ensure that adequate gas service is available and to review applicable installation codes for your area.

Be sure that the gas meter has sufficient capacity to supply the rated gas input of the water heater as well as the requirements of all other gas fired equipment supplied by the meter. If the gas meter is undersized, the gas company will have to install a properly sized gas meter.

	WARNING
	Fire and Explosion Hazard <ul style="list-style-type: none">• Do not use water heater with any gas other than the gas shown on the rating label.• Excessive gas pressure to gas valve can cause serious injury or death.• Turn off gas lines during installation.• Contact a qualified installer or service agency for installation and service.

Make sure gas supplied is same type listed on the water heater's rating label.

The water heaters covered in this manual are not intended for operation at higher than 14.0" W. C. (2.62 kPa) for natural gas and 14.0" W. C. (3.49 kPa) for propane gas supply pressure, see **Table 2** (page 10). The water heaters covered in this manual require supply gas regulators to maintain required supply gas pressure. Exposure to higher gas supply pressure may cause damage to the gas controls which could result in fire or explosion. If overpressure has occurred such as through improper testing of gas lines or malfunction of the supply system the water heater's gas valve must be checked for safe operation by a Qualified Service Agency.

Ensure supply regulator vent lines and the safety vent valves are protected against blockage. These are components of the gas supply system, not the water heater. Vent blockage may occur during ice storms.

It is important to guard against gas valve fouling from contaminants in the gas ways. Such fouling may cause improper operation, fire or explosion. If copper supply lines are used they must be internally tinned and certified for gas service.

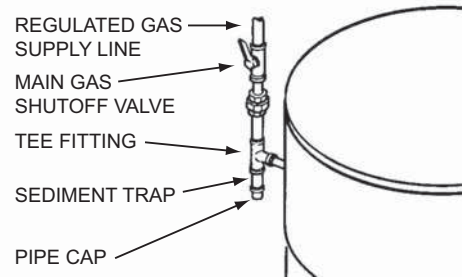



Figure 44. Supply Gas Line Installation

Ensure all gas pipe is clean on the inside before installation. To trap any dirt or foreign material in the gas supply line a sediment trap must be installed as shown in **Figure 44**. The sediment trap must be readily accessible and not subject to freezing conditions. Install in accordance with the recommendations of the local gas utility company.

GAS LINE SIZING

Size the gas pipe appropriately to supply the necessary volume of gas required for the water heater using **ANSI Z223.1/NFPA 54** in the USA or **B149.1** in Canada or local codes. Otherwise, flow capabilities and output temperatures will be limited.

	WARNING
	Fire and Explosion Hazard <ul style="list-style-type: none">• Do not use this water heater with any gas other than the one listed on the rating plate.• Ensure that any and all gas regulators used are operating properly and providing gas pressures within the specified range shown below. Excess gas inlet pressure may cause serious accidents.• Conversion of this unit from natural gas to propane or vice versa will void all warranty. Contact your local distributor to get the correct unit for your gas type. The manufacturer is not liable for any property and/or personal damage resulting from gas conversions.• Failure to observe these warnings could result in severe personal injury, carbon monoxide poisoning, or death.



The minimum and maximum inlet gas pressures must match the ranges specified in **Table 4** (page 13) for the type of gas.

Inlet gas pressures that fall outside the range of values listed in **Table 4** (page 13) may adversely affect the performance of the water heater. These pressures are measured when the water heater is in full operation and in standby.

Inlet gas pressure must not exceed the maximum values; gas pressure above the specified range will cause dangerous operating conditions and damage to the unit.

Until testing of the main gas line supply pressure is completed, ensure the gas line to the water heater is disconnected to avoid any damage to the water heater.

If the gas supply pressure to the heater is greater than the specified maximum, a field-supplied regulator is required. The regulator must lower the gas pressure within the approved range.

Install the gas regulator according to the manufacturer's instructions.



The regulator must be sized for the water heater input and provide the specified pressures that are listed on the rating plate.

In the absence of minimum install distance, it is recommended that there is at least 3 ft (1 m) of piping between the regulator outlet and the water heater's inlet gas connection.

Make sure gas supplied is same type listed on the water heater's rating label.

Exposure to higher gas supply pressure may cause damage to the gas controls which could result in fire or explosion. If overpressure has occurred such as through improper testing of gas lines or malfunction of the supply system the water heater's gas valve must be checked for safe operation by a Qualified Service Agency.

Ensure supply regulator vent lines and the safety vent valves are protected against blockage. These are components of the gas supply system, not the water heater. Vent blockage may occur during ice storms.

	
 WARNING	
Fire and Explosion Hazard	
<ul style="list-style-type: none"> • Turn off all electric power to the water heater if service is to be performed. • Turn the manual gas valve located on the outside of the unit to the off position. • Failure to follow these steps could lead to fire or explosion, resulting in personal injury or death. 	

It is important to guard against gas valve fouling from contaminants in the gas ways. Such fouling may cause improper operation, fire or explosion. If copper supply lines are used they must be internally tinned and certified for gas service.

CALCULATING GAS LINE SIZE

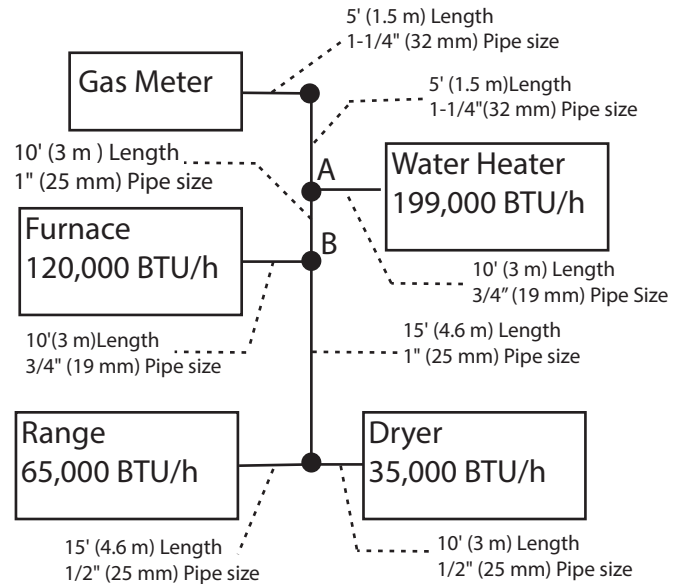

Figure 45. Gas Sizing Example: Natural Gas

To calculate the gas line size based on the energy content of 1,000 BTU/Cubic ft, do the following:

1. Divide each appliance's BTU/h requirement by 1,000 BTU/ft³ to get the appliance's ft³/h requirement.
2. Take into account the distance from the appliance to the gas meter. See **Table 19** (page 41) to properly size the line.
3. For sections of the gas line supplying gas to more than one appliance (Ex: Point A to Point B), add up under the column of 50 ft, Section A to B needs to be 1" in order to supply 220 cubic ft.

For Example: The section from A to B supplies gas to the furnace, range and dryer. Adding up the BTU/h requirements and dividing by 1,000 yields a cubic ft per hour requirement of 220 cubic ft of gas per hour. The farthest appliance is the range, which is 50 ft away from the meter. Looking at the above chart, and under the column of 50 ft, Section A to B needs to be 1" in order to supply 220 cubic ft.

The following tables are from NFPA 54.

Table 19. Natural Gas Supply Piping

Pipe Size	Length												
	10' (3.0 m)	20' (6.1 m)	30' (9.1 m)	40' (12.2 m)	50' (15.2 m)	60' (18.3 m)	70' (21.3 m)	80' (24.4 m)	90' (27.4 m)	100' (30.5 m)	125' (38.1 m)	150' (45.7 m)	200' (61.0 m)
1/2" (13 mm)	172	118	95	81	72	65	60	56	52	50	44	40	34
3/4" (19 mm)	360	247	199	170	151	137	126	117	110	104	92	83	71
1" (25mm)	678	466	374	320	284	257	237	220	207	195	173	157	134
1 1/4" (32mm)	1,390	957	768	657	583	528	486	452	424	400	355	322	275
1 1/2" (38mm)	2,090	1,430	1,150	985	873	791	728	677	635	600	532	482	412
2" (51mm)	4,020	2,760	2,220	1,900	1,680	1,520	1,400	1,300	1,220	1,160	1,020	928	794



Maximum delivery Capacity in Cubic Feet of Gas per Hour (based on IPS Pipe carrying Natural Gas with 0.60 Specific Gravity with a Pressure Drop of 0.5" W.C.).
 Based on Energy Content of 1,000 BTU/Cubic ft: The water heater requires 199 Cubic ft/hr.
 Unit: Cubic feet per hour

Table 20. Propane (LP) Supply Piping

Diameter	Length												
	10' (3.0 m)	20' (6.1 m)	30' (9.1 m)	40' (12.2 m)	50' (15.2 m)	60' (18.3 m)	70' (21.3 m)	80' (24.4 m)	90' (27.4 m)	100' (30.5 m)	125' (38.1 m)	150' (45.7 m)	200' (61.0 m)
1/2" (13 mm)	268	184	148	126	112	101	93	87	82	77	68	62	53
3/4" (19 mm)	567	393	315	267	237	217	196	185	173	162	146	132	112
1" (25mm)	1,071	732	590	504	448	409	378	346	322	307	275	252	213
1 1/4" (32mm)	2,205	1,496	1,212	1,039	913	834	771	724	677	630	567	511	440
1 1/2" (38mm)	3,307	2,299	1,858	1,559	1,417	1,275	1,181	1,086	1,023	976	866	787	675
2" (51mm)	6,221	4,331	3,465	2,992	2,646	2,394	2,205	2,047	1,921	1,811	1,606	1,496	1,260

Maximum Capacity of Propane (LP) Based on 11" W.C. supply pressure at a 0.5" W.C. pressure drop.
 Unit: kBTU per hour

MEASURING INLET GAS PRESSURE

	 <h1 style="margin: 0;">WARNING</h1>
	<p style="text-align: center;">Fire and Explosion Hazard</p> <ul style="list-style-type: none"> • Turn off all electric power to the water heater if service is to be performed. • Turn the manual gas valve located on the outside of the unit to the off position. • Failure to follow these steps could lead to fire or explosion, resulting in personal injury or death.

The water heater cannot perform properly without sufficient inlet gas pressure. Do the following to check the inlet gas pressure. **THIS IS ONLY TO BE DONE BY A LICENSED PROFESSIONAL.**

1. Shut off the manual gas valve on the gas supply line.
2. Remove the screw from the pressure port which is located on the gas inlet of the water heater shown in **Figure 46**.

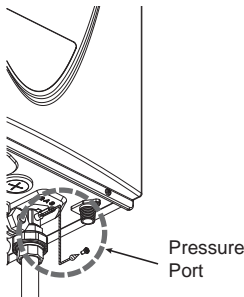

Figure 46. Location of Pressure Port

3. Connect the manometer to the pressure port and zero. Take a reading of the supply dynamic gas pressure with all gas burning equipment running at maximum.
4. Re-open the manual gas valve. Verify that there are no gas leaks.
5. With all gas burning equipment off, take a reading of the static gas pressure and make a note of it.
6. Measure gas supply pressure at minimum heater operation as follows:
 - a. Reduce water flow so the heater is running at minimal operation.
 - b. Press the MIN button on the computer board. See .
 - c. Take a supply gas pressure reading and verify that it is within the specified inlet gas pressure range.

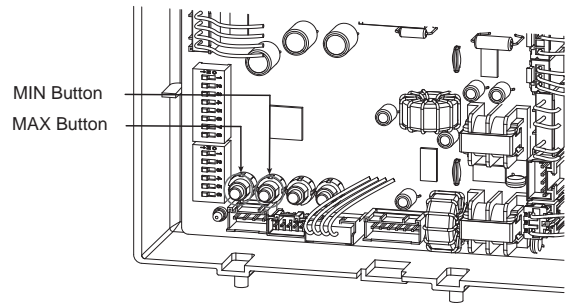



Figure 47. Computer Board

7. Take a reading of the supply dynamic gas pressure with all gas burning equipment running at maximum rate.
8. The static and dynamic pressures should be within the ranges specified on the heater's rating plate and **Table 4** (page 13) .

The difference of static to dynamic pressure should not exceed 1.5" W.C. Pressure drops that exceed 1.5" W.C. can indicate restricted gas flow, undersized gas lines, and/or undersized supply regulators. (NOTICE: In Canada, the pressure drops cannot exceed those specified in CSA B149.1.)

SUPPLY GAS PRESSURE ADJUSTMENT

Supply gas pressure shall be measured while the water heater is not firing (static pressure) AND while the water heater is firing at full capacity (dynamic pressure).

	 <h1 style="margin: 0;">WARNING</h1>
	<p style="text-align: center;">Fire and Explosion Hazard</p> <ul style="list-style-type: none"> • Do not use water heater with any gas other than the gas shown on the rating label. • Excessive gas pressure to gas valve can cause serious injury or death. • Turn off gas lines during installation. • Contact a qualified installer or service agency for installation and service.

If the supply gas pressure to the water heater is not between the required minimum and maximum values given in **Table 2** (page 10) adjust the supply gas regulator as necessary. Adjust the supply gas regulator(s) per the regulator manufacturer's instructions to achieve the required "static" and "dynamic" supply gas pressure.

In multiple water heater installations or in installations where the installed water heater(s) share a common gas supply main with other gas fired appliances; the supply gas pressures shall be measured at each water heater with all gas fired appliances connected to a common main firing at full capacity.

On multiple water heater installations the supply gas line regulators shall be adjusted to provide gas pressure to each water heater within the minimum and maximum supply pressure requirements listed in **Table 2** (page 10) with all gas fired appliances connected to a common gas main firing at full capacity.

NOTE: A pressure drop of more than 1.5" W. C. (0.37 kPa) when the Main Burner ignites is an indication of an inadequate supply of gas and can lead to ignition failure, rough starts and/or rough operation. If a drop of more than 1.5" W. C. (0.37 kPa) in supply gas pressure occurs when the Main Burner ignites, ensure the supply gas lines and regulator(s) are properly sized and installed. See the requirements for **Power Supply** (page 14), **Gas Supply Pressure Requirements** (page 13), and **Supply Gas Line Installation** (page 39). Ensure all requirements and installation instructions are maintained.

GAS LINE CONNECTION

1. Install a manual gas shutoff valve between the water heater and the gas supply line.
2. When the gas connections are completed, it is necessary to perform a gas leak test either by applying soapy water to all gas fittings and observing for bubbles or by using a gas leak detection device.
 - The water heater and its individual shutoff valve must be disconnected from the gas supply piping system during any pressure testing of that system at test pressures in excess of 1/2 psi (3.5 kPa).
 - The water heater must be isolated from the gas supply piping system by closing its individual manual shutoff valve during any pressure testing of the gas supply piping system at test pressures equal to or less than 1/2 psi (3.5 kPa).
3. Always purge the gas line of any debris and/or water before connecting to the gas inlet.

NOTE: If overheating occurs or the gas supply fails to shut off, turn off the Main Gas Shutoff valve to the water heater.

GAS LINE LEAK TESTING

Any time work is done on the gas supply system perform a leak test to avoid the possibility of fire or explosion.

	! WARNING Fire and Explosion Hazard
	<ul style="list-style-type: none"> • Use joint compound or Teflon tape compatible with propane gas. • Leak test gas connections before placing water heater in operation. • Disconnect gas piping at main gas shutoff valve before leak testing heater. • Install sediment trap in accordance with NFPA 54 or CAN/CSA B149.1.

1. For test pressures exceeding 1/2 psi (3.45 kPa) disconnect the water heater and its Main Gas Shutoff Valve from the gas supply piping system during testing, see **Figure 44** (page 39). The gas supply line must be capped when disconnected from the water heater.
2. For test pressures of 1/2 psi (3.45 kPa) or less, the water heater need not be disconnected, but must be isolated from the supply gas line by closing the Main Gas Shutoff Valve during testing.
3. Paint all supply gas line joints and connections upstream of the water heater with a rich soap and water solution to test for leaks. Bubbles indicate a gas leak. Do not use matches, candles, flame or other sources of ignition for this purpose.
4. Repair any leaks before placing the water heater in operation.

PURGING

Gas line purging is required with new piping or systems.

Purging should be performed per the current edition of **NFPA 54** the **National Fuel Gas Code** or **CAN/CSA B149.1** **Natural Gas and Propane Installation Code**.

ELECTRICAL CONNECTIONS

All electrical work must be installed in accordance with the **National Electrical Code, ANSI/NFPA 70** or the **Canadian Electrical Code, CSA C22.1** and local requirements.

When installed, the water heater must be electrically grounded in accordance with local codes or, in the absence of local codes, with the **National Electrical Code, ANSI/NFPA 70** or the **Canadian Electrical Code, CSA C22.1**.

If any of the original wire as supplied with the water heater must be replaced, it must be replaced with 105°C rated wiring or its equivalent, except in the burner housing. In this case 200°C rated wire must be used.

	! WARNING Shock or Electrocutation Hazard
	<ul style="list-style-type: none"> • Follow the electrical code requirements of the local authority having jurisdiction. In the absence of such requirements, follow the current edition of the National Electrical Code ANSI/NFPA 70 in the U.S. or the current edition of CSA C22.1 Canadian Electrical Code Part 1 in Canada. • When servicing or replacing parts within the water heater, label all wires prior to disconnection to facilitate an easy and error-free reconnection. Wiring errors can cause improper and dangerous operation. Verify proper operation after servicing. • Failure to observe these warnings could result in personal injury or death.

DEDICATED POWER WIRING AND BREAKERS

Dedicated power supply wires, neutral wires, ground wiring, and dedicated circuit breakers often prevent electrical line noise and are required when installing the water heater.

NOTE: This water heater should not be connected to an electrical supply with a Ground Fault Circuit Interrupter (GFCI) or Arc Fault Circuit Interrupter (AFCI) with Integral GFCI protection as defined in **NFPA 70, CSA C22.1** and **UL 943**.

POWER SUPPLY CONNECTIONS

Read the requirements for the **Power Supply** (page 14) before connecting power.

Note: The water heater comes with a power plug instead of a junction box.

WATER LINE CONNECTIONS

The water piping installation must conform to these instructions and to all local and national code authority having jurisdiction. Good practice requires that all heavy piping be supported.

Read and observe all requirements in the following sections before installation of the water piping begins:

1. **Mixing Valves** (page 14).
2. **Note:** Malfunctions caused by the power supply and costs to install power supply filters are not covered under the limited warranty. See the Commercial Water Heater Limited Warranty provided with this water heater.
3. **Dish-washing Machines** (page 15).
4. **Water Line Connections** (page 44).
5. **Thermal Expansion** and **Closed Water Systems** (page 15)
6. For multiple water heater installations see **Water Piping Diagrams** (page 66).

WATER PIPING DIAGRAMS

This manual provides detailed water piping diagrams for typical methods of application for the water heaters, see **Water Piping Diagrams** (page 66).

The water heater may be installed with or without a separate storage tank. When used with a separate storage tank, the circulation may be either by gravity or by means of a circulating pump. When a circulating pump is used, it is important to note that the flow rate should be slow so that there will be a minimum of turbulence inside the water heater storage tank.

Adjust flow by throttling a full port ball valve installed in the circulating line on the outlet side of the pump. Never throttle flow on the suction side of a pump. See the **Water Piping Diagrams** (page 66).

NOTE: In addition to the factory installed Temperature-Pressure Relief valve (T&P valve) on the water heater, each remote storage tank that may be installed and piped to a water heating appliance must also have its own properly sized, rated and approved Temperature-Pressure Relief valve installed.

Call the toll free technical support phone number listed on the back cover of this manual for further assistance in sizing a T&P valve for remote storage tanks.

THERMOMETERS (NOT SUPPLIED)

Thermometers are installed in the water piping system as a means of detecting the temperature of the hot water supply at critical points in the system. Field-supplied thermometers should be obtained and installed. See **Water Piping Diagrams** (page 66).

WATER (POTABLE) HEATING AND SPACE HEATING

1. All water piping components connected to the water heater that are for space heating applications shall be suitable for use with potable water.
2. Toxic chemicals, such as those used for boiler treatment, must NEVER be introduced into this system.
3. The water heaters covered in this manual may never be connected to any existing heating system or component(s) previously used with non-potable water heating appliance.
4. When the system requires water for space heating that exceed safe temperatures at domestic water fixtures a mixing valve must be installed. See **Mixing Valves** (page 14).
Note: Malfunctions caused by the power supply and costs to install power supply filters are not covered under the limited warranty. See the Commercial Water Heater Limited Warranty provided with this water heater.
5. These water heaters cannot be used in space heating applications only.

T&P VALVE DISCHARGE PIPE

This water heater is provided with a properly rated/sized and certified combination temperature - pressure (T&P) relief valve by the manufacturer. **Water Line Connections** (page 44) and **Water Piping Diagrams** (page 66) for information on replacement and other requirements.

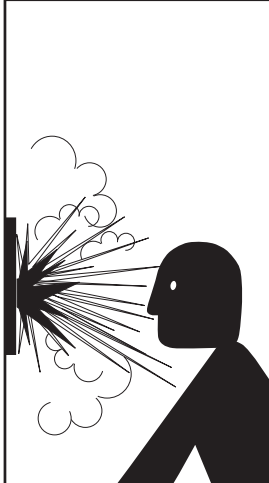
	! WARNING
	Explosion Hazard
	<ul style="list-style-type: none">• Temperature-Pressure Relief Valve must comply with ANSI Z21.22- CSA 4.4 and ASME code.• Properly sized temperature-pressure relief valve must be installed in opening provided.• Can result in overheating and excessive tank pressure.• Can cause serious injury or death.

CAUTION

Water Damage Hazard

- Temperature-Pressure Relief Valve discharge pipe must terminate at adequate drain.

Install a discharge pipe between the T&P valve discharge opening and a suitable floor drain. Do not connect discharge piping directly to the drain unless a 6" (15.2 cm) air gap is provided. To prevent bodily injury, hazard to life, or property damage, the relief valve must be allowed to discharge water in adequate quantities if circumstances demand. If the discharge pipe is not connected to a drain or other suitable means, the water flow may cause property damage.

T&P Valve Discharge Pipe Requirements:

- Shall not be smaller in size than the outlet pipe size of the valve, or have any reducing couplings or other restrictions.
- Shall not be plugged or blocked.
- Shall not be exposed to freezing temperatures.
- Shall be of material listed for hot water distribution.
- Shall be installed so as to allow complete drainage of both the Temperature-Pressure Relief Valve and the discharge pipe.
- Must terminate a maximum of six inches above a floor drain or external to the building. In cold climates, it is recommended that the discharge pipe be terminated at an adequate drain inside the building.
- Shall not have any valve or other obstruction between the relief valve and the drain.

TEMPERATURE REGULATION

HIGH TEMPERATURE LIMIT CONTROL (ECO)

This water heater is equipped with a non adjustable high temperature limit switch. The switch is a normally closed switch that opens (activates) on a rise in temperature.

If the switch activates (contacts open) due to abnormally high water temperatures water heating unit, the control system will immediately close the gas valve and end the current heating cycle. The control system will "lock out" disabling further heating operation.

THERMOSTAT CONTROL

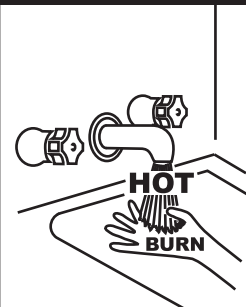

⚠ DANGER

Water temperature over 125°F (52°C) can cause severe burns instantly resulting in severe injury or death.

Children, the elderly and the physically or mentally disabled are at highest risk for scald injury.

Feel water before bathing or showering.

Temperature limiting devices such as mixing valves must be installed when required by codes and to ensure safe temperatures at fixtures.

Hot water temperatures required for automatic dishwasher and laundry use can cause scald burns resulting in serious personal injury and/or death. **Table 21** (page 46) shows the approximate time-to-burn relationship for normal adult skin.

The temperature at which injury occurs varies with the person's age and duration of exposure. The slower response time of children, the elderly or disabled persons increases the hazards to them. If anyone using hot water provided by the water heater being installed fits into one of these groups or if there is a local code or state law requiring a certain water temperature at the point of use, then special precautions must be taken.

In addition to using the lowest possible temperature setting that satisfies the demand of the application a mixing valve can be installed at the water heater or at the hot water taps to further reduce system water temperature. See **Figure 7** (page 15).

Never allow small children to use a hot water tap or draw their own bath water. Never leave a child or disabled person unattended in a bathtub or shower.

The water heater should be located in an area where the general public does not have access to set temperatures.

Setting the Operating Set Point at 120°F (49°C) will reduce the risk of scalds. Some States require settings at specific lower temperatures.

Table 21. Time/Temperature to Burn

Water Temperature °F (°C)	Time for 1st Degree Burn (Less Severe Burns)	Time for Permanent Burns 2nd & 3rd Degree (Most Severe Burns)
110 (43)	(normal shower temp.)	
116 (47)	(pain threshold)	
116 (47)	35 minutes	45 minutes
122 (50)	1 minute	5 minutes
131 (55)	5 seconds	25 seconds
140 (60)	2 seconds	5 seconds
149 (65)	1 second	2 seconds
154 (68)	instantaneous	1 second

(U.S. Government Memorandum, C.P.S.C., Peter L. Armstrong, Sept. 15, 1978)

The water heaters covered in this manual are equipped with an electronic control system to regulate water temperature inside the storage tank. The control system uses temperature sensors installed in the tank and in the water heating unit.

There are two factory-installed temperature probes in the storage tank that help the pump controller determine when to run the pump. One is installed in the top of the storage tank and one installed near the bottom. The controller learns the approximate set point for controlling the pump and there is no need to adjust the set point manually.

There are four temperature sensors in the water heating unit that monitor the water temperature at various points within the unit and the temperature of the exhaust gas. The water heating unit computer uses the sensor information to modulate the gas and water valves to ensure proper output water temperature and hot water outflows.

FIRING RATE MODULATION

The water heating unit controller regulates the firing rate to achieve the target temperature setpoint. The firing rate is dictated by the hot water draw, proximity to the tank temperature setpoint, and various other temperature limitations.

HIGH TEMPERATURE APPLICATIONS

Higher operating temperatures cause more wear on all water heaters and will decrease the life span of the water heater. Consider installing a small booster water heater for high temperature applications, such as commercial dishwashers, to raise the outlet temperature from the larger primary water heater to the desired point-of-use temperature.

Contact your local distributor or call the technical support phone number listed on the back cover of this manual for further technical assistance.

CONTROL SYSTEM OPERATION

The water heaters covered in this manual are equipped with an electronic control system that regulates water temperature inside the storage tank. Heating cycles and ignition are managed by the control system. The high-limit switch, flame sensor, pressure switches, and temperature probes are monitored by the control system.



TEMPERATURE REMOTE CONTROLLER

Included Accessories

The remote control is an optional accessory that can be installed in a hall, closet, etc., to allow for temperature adjustment without having to go to the heater.

When installed, the remote will take priority over the built-in controller.

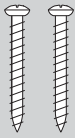
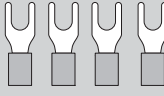
Verify that the items listed below are included with the remote controller.

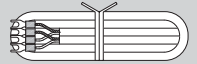
Remote Temperature Control	 Qty. 1
Screws	 Qty. 2
Fork Terminals	 Qty. 4
Manual	 Qty. 1
Remote Control Cable	 Qty. 1

100209924 (TM-RE42)

It is also an optional accessory as a second remote. *The optional remote controller (sold separately) has no remote controller cable.

INSTALLATION

Do not place the remote controller cable close to other wires from other products.

Cables used for the remote controller connection must be:

- Minimum 20 gauge wire (No polarity)
- Maximum 400 ft (122 m) long



WARNING

Shock or Electrocuting Hazard

- This remote controller is NOT waterproof.
- The water heater can only have one remote controller.
- Do not install in high temperature environments, high humidity conditions outdoors, in direct sunlight, or within the reach of children.
- Make sure the remote controller does not come into contact with water or oil.
- Failure to observe these warnings could result in personal injury or electrical shock.



MOUNTING AND WIRING THE REMOTE CONTROLLER

1. Take off the Back plate from the remote controller with a flat head screwdriver.

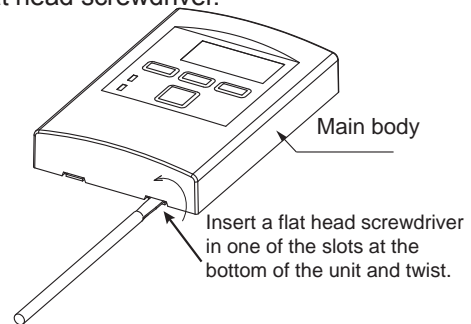

Figure 48. Removing the Cover

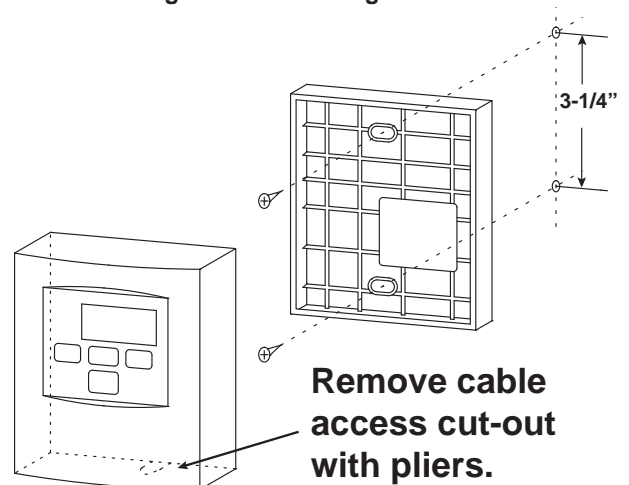

Figure 49. Attaching the Back Plate

2. Attach the Back plate to the wall with the two provided screws. (Fig. B)
3. If you use another cable, crimp the Fork terminals to the wires.

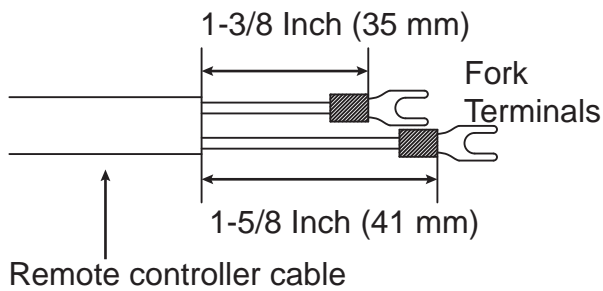

Figure 50. Remote Cable Fork Terminals

4. Tighten the two Fork terminals beneath the two remote controller terminal screws on the back of the controller.
5. Remove the cable access cut out from the bottom of the controller.
6. Place the Main body back on the Back plate, with the Remote controller cable running out of the bottom inlet. See **Figure 51**.

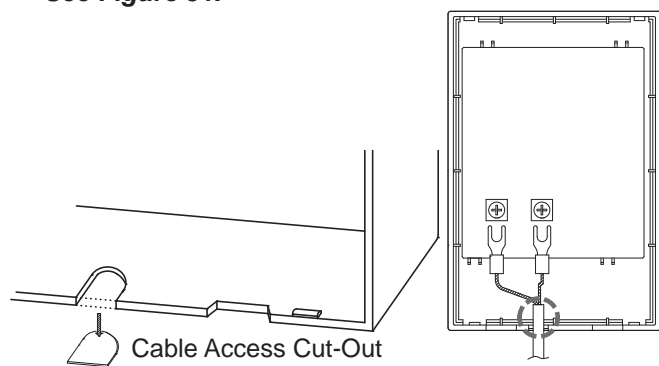

Figure 51. Cable Access Cut-Out and Terminal Connection

CONNECTING THE REMOTE CONTROLLER TO THE WATER HEATER

1. Disconnect power supply from the water heater.
2. Take off the water heater's front cover.
3. Locate the two terminals for the remote controller in the water heater. (Refer to **Figure 51**.)
4. Take off the back plate from the remote controller, and then attach the two fork terminals to the connector base on the back side of the remote controller with two screws. Make sure the terminals are firmly fixed. (See the above instructions for installation of the remote controller.)
5. Pull the remote controller cable through the hole at the bottom of the water heater's casing.
6. Secure both controller cable terminals to the terminals on the computer board as shown below. (Secure them underneath the screw terminals. No polarity.)
* Do NOT jump or short-circuit the cables, or computer will be damaged.
7. Replace the front cover securely.

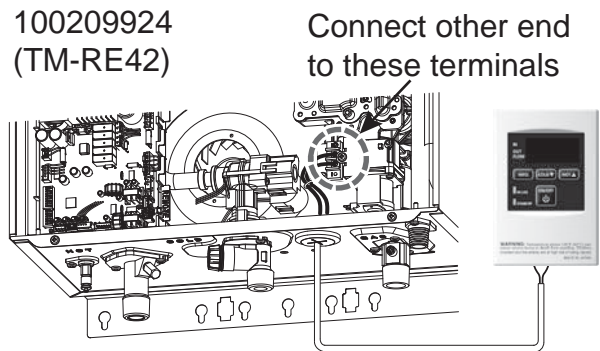

Figure 52. Remote Controller Connection to Water Heating Unit

START UP

PRIOR TO START UP

Installation and start up of this water heater requires abilities and skills equivalent to that of a licensed tradesman in the field involved. See **Qualifications** (page 6).

DO NOT USE THIS APPLIANCE IF ANY PART HAS BEEN EXPOSED TO FLOODING OR WATER DAMAGE.

Immediately call a qualified service agency to inspect the appliance and to make a determination on what steps should be taken next. If the unit is exposed to the following, do not operate heater until all corrective steps have been made by a qualified service agency.

1. External fire
2. Damage
3. Firing without water

Light the water heater in accordance with the Lighting and Operation Instruction label on the water heater and in this manual **Lighting the Water Heater** (page 50).

The water heaters covered by this manual are equipped with an electronic control system, which automatically sequences the Combustion Blower, pre and post purging of the combustion chamber, the spark transformer, the 24-volt gas valve, Main Burner ignition, and flame sensing. The control system will lock out after three unsuccessful ignition attempts. See **Control System Operation** (page 47).

START-UP PREPARATION

Before attempting start up, ensure the water heater is properly grounded. Flame sensing requires an adequate earth ground. If the water heater is not properly grounded it will cause Ignition Failure. See **Electrical Connections** (page 54).

Be certain that the water heater is full of water, that air is purged from the gas and water lines and that there are no leaks in the gas and water lines. Ensure all inlet water valves are open.

FILLING THE WATER HEATER STORAGE TANK

Follow these steps to fill the water heater prior to start up.

1. Close the storage tank drain valve.
2. Open a nearby hot water faucet to permit air in system to escape.
3. Fully open the cold water inlet valve allowing the piping and storage tank to fill with water.
4. Close the hot water faucet opened in Step 2 as water starts to flow from the faucet.

The water heater pump and piping is below the water level of the filled storage tank and gravity ensures that the water fills the piping and pump. It is not necessary to prime the pump.

In the unlikely event that the pump piping becomes blocked, a flow sensor detects the problem and prevents the water heating unit from firing without water.

INITIAL OPERATION

FOR YOUR SAFETY, READ BEFORE OPERATING

1. Check the GAS and WATER CONNECTIONS for leaks before firing unit for the first time.
2. Open the main gas supply valve to the unit using only your hand to avoid any spark. Never use tools. If the knob will not turn by hand, do not try to force it; call a qualified service technician. Forced repair may result in a fire or explosion due to gas leaks.
3. Be sure to check for the presence of leaking gas toward the bottom of the unit because some gases are heavier than air and may settle towards the floor.
4. Measure the Static Supply Gas Pressure. See **Measuring Inlet Gas Pressure** (page 42).
5. Confirm that the measurement is within operating parameters. See **Table 4** (page 13).
6. Adjust the pressure if necessary. See **Supply Gas Pressure Adjustment** (page 42).
7. Do not try to light the burner manually. It is equipped with an electronic ignition device which automatically lights the burner.
8. Check for PROPER VENTING and combustion air to the water heater.
9. Purge the GAS and WATER LINES to remove any air pockets.
10. Do not use this appliance if any part has been under water. Immediately contact a qualified installer or service agency to replace a flooded water heater. Do not attempt to repair the unit! It must be replaced!

FLOW RATES

The following are the minimum flow rates:

- Flow rate to activate the water heater: 0.5 gallon per minute at the default set temperature (1.9 L/min).
- Flow rate to keep the water heater running: 0.4 gallon per minute (1.5 L/min).

LIGHTING THE WATER HEATER

The instruction label below is affixed to the water heaters that are covered by this manual at the factory and must be followed when lighting and operating the water heater.

FOR YOUR SAFETY READ BEFORE OPERATING

WARNING: If you do not follow these instructions exactly, a fire or explosion may result causing property damage, personal injury or loss of life.

- A. This appliance does not have a pilot. It is equipped with an ignition device which automatically lights the burner. Do not try to light the burner by hand.
- B. BEFORE OPERATING smell all around the appliance area for gas. Be sure to smell next to the floor because some gas is heavier than air and will settle on the floor.
- WHAT TO DO IF YOU SMELL GAS
- Do not try to light any appliance.
 - Do not touch any electric switch; do not use any phone in your building.
 - Immediately call your gas supplier from a neighbor's phone. Follow the gas supplier's instructions.
 - If you cannot reach your gas supplier, call the fire department.
- C. Use only your hand to turn the gas shutoff valve. Never use tools. If the valve will not turn by hand, don't try to repair it, call a qualified service technician. Force or attempted repair may result in a fire or explosion.
- D. Do not use this appliance if any part has been under water. Immediately contact a qualified installer or service agency to replace a flooded water heater. Do not attempt to repair the unit! It must be replaced!

OPERATING INSTRUCTIONS

1. **STOP!** Read the safety information above on this label.
2. Turn off all electric power to the appliance.
3. Do not attempt to light the burner by hand.
4. Turn the gas shutoff valve located on the outside of the unit to the closed position.
5. Wait five (5) minutes to clear out any gas. If you then smell gas, STOP! Follow "B" in the safety information above on this label. If you don't smell gas, go to the next step.
6. Turn the gas shutoff valve located on the outside of the unit to the open position.
7. Turn on all electrical power to the appliance.
8. If the appliance will not operate, follow the instructions in "To Turn Off Gas to Appliance," and call your service technician or gas supplier.

TO TURN OFF GAS TO APPLIANCE

1. Turn off all electric power to the appliance if service is to be performed.
2. Turn the gas shutoff valve located on the outside of the unit to the closed position.

⚠ DANGER

⚠ **Vapors from flammable liquids will explode and catch fire causing death or severe burns.**

Do not use or store flammable products such as gasoline, solvents or adhesives in the same room or area near the water heater.

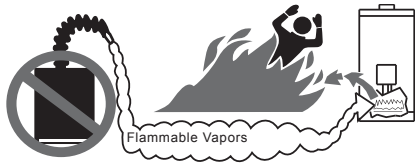

Do not install water heater where flammable products will be stored or used unless the main burner is at least 18" above the floor. This will reduce, but not eliminate the risk of vapors being ignited by the main burner.

FLAMMABLES

Read and follow water heater warnings and instructions. If the owner's manual is missing, contact the retailer or manufacturer.

Keep flammable products:

1. Far away from heater.
2. In approved containers.
3. Tightly closed and out of reach of children.
4. Water heater has a main burner, which may come on at any time and will ignite flammable vapors.

Vapors:

1. Cannot be seen.
2. Are heavier than air.
3. Go a long way on the floor.
4. Can be carried from other rooms to the main burner by air currents.

⚠ DANGER

1. Water temperature over 125°F (52°C) can cause severe burns instantly or death from scalds.
2. Children, disabled and elderly are at highest risk of being scalded.
3. Feel water before bathing or showering.
4. Temperature limiting valves are available. See manual.
5. The outlet temperature of the water heater is set at 120°F (50°C). If you require water temperatures below this setting, follow the instruction manual.
6. Use this heater at your own risk. Test the water before bathing or showering. Do not leave children or an infirm person unsupervised. See your local water supply company [plumbing hardware retailer] for temperature limiting valves that are available.



A pressure relief valve listed as complying with the standard for **Relief Valve and Automatic Gas Shutoff Devices for Hot Water Supply System, ANSI Z21.22 • CSA 4.4**, shall be installed at the time of installation of the water heater in the location specified by the manufacturer. Local codes shall govern the installation of relief devices for safety operation of the water heater. The relief valve must not be removed or plugged.

No valve shall be placed between the relief valve and the water heater. The relief from the discharge of the pressure relief valve shall be disposed of in a suitable place where it will cause no damage. Also, there shall be no other reducing coupling or other restrictions installed on the discharge line to restrict flow.

NORMAL OPERATION

The water heater has a built-in control panel on the side of the unit. You can also order the remote controller for use with the water heater. If you use the remote control, temperature and flow settings you set take precedence over the built-in control panel.

When the water heater is connected with the remote controller, the built-in controller will not operate temperature settings. It will only work for the information mode.

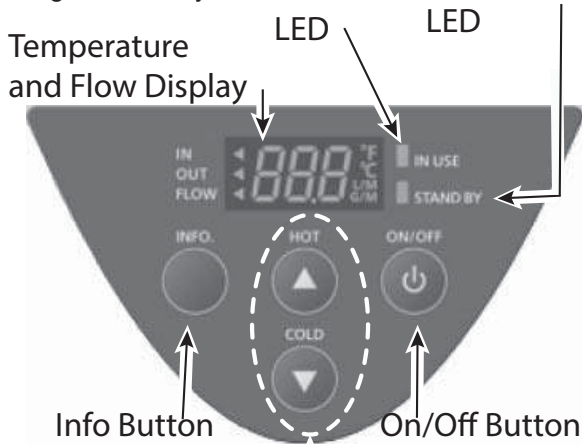

Figure 53. Built-In Control Panel

The controller has an energy saving mode. Five minutes after the water heater stops operating, the backlight of the controller turns off. The backlight of the remote will turn back on once the water heater begins firing again.

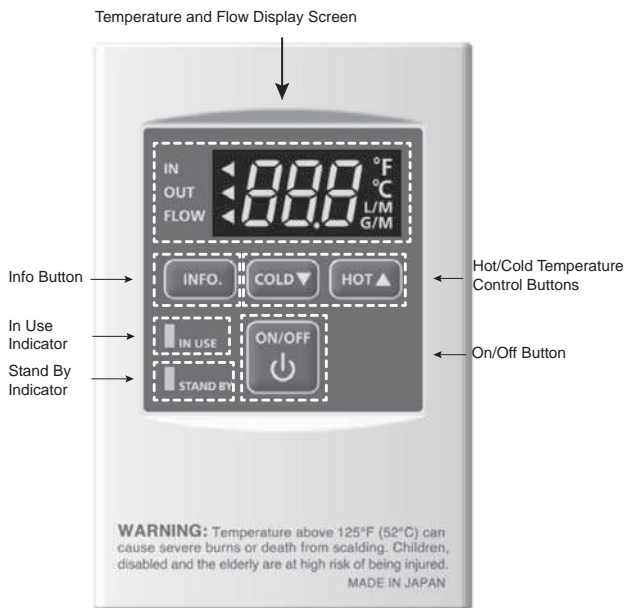

Figure 54. Remote Controller

The built-in control panel and the remote controller have the

same indicators and buttons, although they are arranged differently.

- **Temperature and Flow Display** - runs in three display modes: Inlet Temperature, Outlet Temperature, and Water Flow. Switch between modes by pressing the Info button.
- **Info Button** - Switches the display among the three display modes: Inlet Temperature, Outlet Temperature, and Water Flow.
- **In-Use Indicator** - lights up when the burner is running.
- **Stand By Indicator** - indicates that the power is on.
- **Hot and Cold Temperature Control Buttons** - increase or decrease the temperature settings for the Outlet temperature setting.
- **On/Off Button** - Turns power to the controller on and off. This effectively enables and disables the water heating function, but the power to the water heater stays on.

SETTING THE OUTLET WATER TEMPERATURE

In general, you set the outlet temperature using the HOT and COLD buttons, but a two-button safety sequence is required to increase the temperature from 120 °F (50 °C) to 125 °F (52 °C) and from 140 °F (60 °C) to 145 °F (63 °C). This is to prevent setting the outlet temperature too high unintentionally.

1. Turn on the 120 VAC power supply to the unit (the water heater or the multi-unit controller).
2. Press the "ON/OFF" button on the controller in order to turn the controller on. When ON, the STAND BY LED is lit. It shows the set temperature on its display as shown in the picture on the right. (EX.: 120 °F)
3. Press the "HOT" button to increase the temperature or the "COLD" button to decrease the temperature setting of the unit.

To increase the temperature from 120 °F (50 °C) to 125 °F (52 °C):

- a. Press the "HOT" button to increase the temperature up to 120 °F (50 °C).
- b. Press and hold the "INFO" button and the "HOT" button for at least 3 seconds. The display will flash and change to 125 °F (52 °C).
- c. Press the "HOT" button to increase the temperature from 125 °F (52 °C) to 140 °F (60 °C).

To increase the temperature above 140 °F (60 °C):

- a. Press the "HOT" button to increase the temperature up to 140 °F (60 °C).
- b. Press and hold the "INFO" button and the "HOT" button for at least 3 seconds. The display will flash and the temperature will change to 145 °F (63 °C)
- c. Press the "HOT" button to set the temperature above 145 °F (63 °C) up to 185 °F (85 °C) .

The following are the possible settings for the outlet temperature:

°F	100	105	110	115	120*	125	130	135	140	145	150	155	160	165	175	185
°C	38	40	43	45	50*	52	55	57	60	63	65	68	70	75	80	85

Factory Setting (Default): 120 °F (50 °C).

DEFAULT OUTLET TEMPERATURE

The factory setting for the default outlet temperature is 120 °F (50 °C) but you can set it to either 120 °F (50 °C) or 140 °F (60 °C) by changing the DIP switch settings on the computer board.

When the remote controller is in normal operation, the set temperature of the remote controller is given priority over the set temperature of the DIP switch settings.

To change the default outlet temperature, do the following:

1. Disconnect power supply from the water heater.
2. Take off the water heater's upper front cover.
3. Locate the computer board in the unit case. See **Figure 3** (page 8).
4. Remove the computer board cover.
5. Locate the lower bank DIP switches on the computer board.

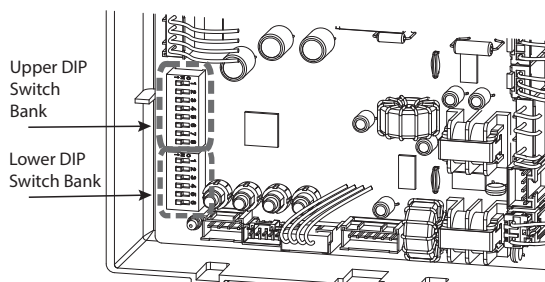

Figure 55. Location of DIP Switches

6. On the lower DIP switch bank, note the position of DIP Switch 5.

Table 22. DIP Switch Settings for Default Outlet Temperature

	120 °F (50 °C) DEFAULT	140 °F (60 °C)
ON	1 2 3 4 5 6	1 2 3 4 5 6
OFF	<input type="checkbox"/> <input type="checkbox"/> <input type="checkbox"/> <input type="checkbox"/> <input checked="" type="checkbox"/> <input type="checkbox"/>	<input type="checkbox"/> <input type="checkbox"/> <input type="checkbox"/> <input type="checkbox"/> <input type="checkbox"/> <input checked="" type="checkbox"/>
	No. 5 : OFF	No. 5 : ON

NOTE: The dark squares indicate the position of the DIP switch.

7. Use a pencil or screw driver to flip Switch 5 to the position corresponding to the default outlet temperature setting you want. Do not flip or disturb any other DIP switches.
8. Replace the computer board cover.
9. Replace the water heater's upper front cover.
10. Reconnect the power supply to the water heater.

SETTING UNITS OF MEASURE

You can specify whether you want the water heater to display temperatures and flow rates in terms of Imperial or Metric units. The Imperial units are **Fahrenheit degrees** (°F) for temperature and **gallons per minute** (gpm) for flow. The Metric units are **Celsius degrees** (°C) for temperature and **liters per minute** (lpm) for flow.

Do the following to switch between the two unit systems:

1. Press the "ON/OFF" button on the controller in order to turn the controller on. When ON, the orange LED is lit.
2. The Temperature and Flow Display screen shows the current temperature setting for Outlet Temperature. You can tell which unit system is set by noting whether the temperature setting is in Celsius degrees or Fahrenheit degrees.
3. To switch to the other unit system, press and hold the "INFO" button for at least 3 seconds.
4. The set temperature should now be displayed in the alternate unit of measurement.

Note: When the water heater is connected to the remote controller, the built-in controller will not operate temperature settings. It will only work for the information mode.

FREEZE PROTECTION SYSTEM

This water heater comes equipped with heating blocks to protect it from damage associated with freezing. When the freeze protection thermostat senses air temperature below 36.5 °F (2.5 °C), the blocks will heat up to prevent freezing of the unit.

To operate these freeze protection systems, there has to be electrical power to the unit. Damage to the heat exchanger caused by freezing temperatures due to power loss is not covered under the warranty. In cases where power losses can occur, consider the use of a backup power supply.

The manufacturer also highly recommends the use of a back-flow preventer (sold separately) to minimize the amount of cold air entering through the exhaust venting when the water heater is off.

It is the installer's responsibility to be aware of freezing issues and take all preventative measures. The manufacturer will not be responsible for any damage to the heat exchanger as a result of freezing.

If you will not be using your heater for a long period of time, do the following:

1. Completely drain the water out of the unit. See **Draining the Water Heating Unit** (page 62).
2. Disconnect power to your heater.

This will keep your unit from freezing and being damaged.

TROUBLESHOOTING

INSTALLATION CHECKLIST

The list below represents some of the most critical installation requirements that, when overlooked, often result in operational problems, down time and needless parts replacement. This is not a complete list. Before performing any troubleshooting procedures use the list below to check for installation errors.

Note: Costs to correct installation errors are not covered under the limited warranty. See the Commercial Water Heater Limited Warranty provided with this water heater.

Ensure all installation requirements and instructions in this manual have been maintained and followed.

WATER HEATER LOCATION

1. Ensure proper clearances to combustibles are maintained and there is sufficient room to service the water heater. See **Clearance To Combustible Materials** (page 11).
2. Ensure the area is free of corrosive elements and flammable materials. See the instructions in **Combustible Material Storage** (page 17).

VENTING

1. Ensure the intake air and/or vent (exhaust) piping is the correct size for the installed length. See **Ventilation Requirements** (page 18).
2. Ensure the maximum equivalent feet of pipe has not been exceeded for the intake air and/or vent pipe. See **Table 7** (page 21).
3. Ensure the maximum number of elbows has not been exceeded in the intake air and/or vent pipe. See **Table 7** (page 21).
4. Ensure the intake air screen has been removed from the intake air connection on the water heater when installing the water heater in a Direct Vent configuration. See **Direct Vent Installations** (page 22).
5. Ensure all exterior clearances for the intake air, vent, and concentric terminations are maintained. See **Figure 17** (page 22), **Concentric Termination Installation** (page 29). These clearances and those cited by local and national codes must be maintained.

GAS SUPPLY AND PIPING

1. Ensure a supply gas regulator has been installed for each water heater. See the requirements for a **Power Supply** (page 14).
2. Ensure the supply gas line to each water heater meets the minimum supply gas line size requirements. See the requirements for the **Gas Supply Pressure Requirements** (page 13) and the installation instructions in **Gas Line Sizing** (page 39) and **Supply Gas Pressure Adjustment** (page 42).

CONDENSATE DRAIN

Ensure there is a proper condensate drain tube connected to the water heating unit

ELECTRICAL CONNECTIONS

1. Ensure the power supply connections to the water heater are polarity correct. See the requirements for the **Power Supply** (page 14) and **Electrical Connections** (page 43).
2. Ensure the water heater is properly grounded. Flame sensing requires an adequate earth ground. If the water heater is not properly grounded it will cause Ignition Failure.

OPERATIONAL PROBLEMS

	WARNING
	Read and understand this instruction manual and the safety messages herein before installing, operating or servicing this water heater.
	Failure to follow these instructions and safety messages could result in death or serious injury. This manual must remain with the water heater.

This section of the manual is intended to be an aid in correcting common operational problems, it is not all inclusive. The installer may be able to observe and correct certain problems which might arise when the water heater is first put into operation or when it is re-fired after a prolonged shutdown. However, only qualified service agents, as defined in Qualifications on page 6, using appropriate test equipment, should perform any service procedures on the water heater.

NOTE: Call the technical support phone number listed on the back cover of this manual for further technical assistance or to locate a qualified service agent in your area.

INSTALLATION ERRORS

Operational problems on new installations are often the result of installation requirements that have been overlooked rather than failed components. IE: A "Low Gas Pressure" Fault condition is most often caused by low supply gas pressure rather than a defective Low Gas Pressure switch. Rough starting and rough operation are often caused by undersized supply gas lines and/or the absence of a supply gas regulator at the water heater.

Prior to performing any operational checks inspect the water heater installation to ensure all installation requirements and instructions have been maintained and followed. See the **Installation Checklist** (page 54).

NOTE: Costs to correct installation errors are not covered under the limited warranty. See the Commercial Water Heater Limited Warranty provided with this water heater.

ROUGH STARTING, ROUGH OPERATION

	⚠ WARNING
	Fire and Explosion Hazard <ul style="list-style-type: none">• Do not use water heater with any gas other than the gas shown on the rating label.• Excessive gas pressure to gas valve can cause serious injury or death.• Turn off gas lines during installation.• Contact a qualified installer or service agency for installation and service.

- Undersized supply gas line (low volume of supply gas) - see **Gas Supply Pressure Requirements** (page 13).
- Supply gas regulator is not installed per installation requirements (erratic gas supply volume/pressures) - see **Power Supply** (page 14).
- Excessive supply gas pressure - see **Table 2** (page 10) and **Freeze Protection System** (page 53).
- Vent (exhaust) gas recirculation at the vent and intake air pipe terminations on a direct vent installation - see **Direct Vent Installations** (page 22).
- Excessive equivalent lengths of intake air and/or vent (exhaust) piping installed - see **Ventilation Requirements** (page 18).
- Debris clogging/blocking the intake air screen(s).
- Debris clogging/blocking the Main Burner - see **Figure 3** (page 8).

MOMENTARY IGNITION

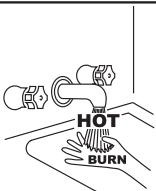
	⚠ CAUTION
	Burn Hazard <ul style="list-style-type: none">• The combustion chamber and burner sleeve and housing become very hot during operation.• Do not reach into the burner housing or combustion chamber if the water heater is still hot.• Allow the water heater to cool and always use gloves when handling the main burner.

If the Main Burner ignites momentarily but does not sustain ignition, allow the water heater to try to ignite up to two more times until control system locks out and the Ignition Failure Fault message is displayed on the control system's LCD. If the water heater is experiencing rough starts - see **Rough Starting, Rough Operation** (page 55). For momentary ignition problems without rough starting check the following:

- Undersized supply gas line (low volume of supply gas) - see **Gas Supply Pressure Requirements** (page 13).
- Supply gas regulator is not installed per installation requirements (erratic gas supply volume/pressures) - see **Power Supply** (page 14).

- See the list of possible causes and things to check and repair for the Ignition Failure Fault message in **Water Heating Unit Controller Fault and Alert Conditions** (page 56).
- Debris clogging/blocking the intake air screen(s) .
- Debris clogging/blocking the Main Burner - see **Figure 3** (page 8).

NOT ENOUGH OR NO HOT WATER

- No power to the water heater, check breaker and fuses.
- Hot water supply valve(s) to fixtures closed.
- Operating Set Point is set too low. See **Control System Operation** (page 47).
- Ensure there is not any external supervisory control disabling heating operation.
- The heating capacity of the water heater has been exceeded, the water heater is unable to meet demand.
- Colder incoming water temperature lengthening the time required to heat water to desired temperature.
- Hot water piping leaks, open faucets, water heater drain valve leaking or open.
- Sediment or lime scale accumulation may be affecting water heater operation. See **Maintenance** on page 61 for sediment and lime scale removal procedures.
- Water heater not firing at full input rating. Check actual firing rate of the water heater, see instructions in **Freeze Protection System** (page 53). Note that the water heaters covered by this manual are capable of modulating their firing rate. The firing rate is dictated by the hot water draw and various other temperature limitations.

WATER IS TOO HOT

- Operating Set Point is set too high.
- If installed, check Thermostatic Mixing Valve settings.
- Improper water piping - see **Water Piping Diagrams** (page 66).

NOISY OPERATION

- Sediment or lime scale accumulations can cause rumbling and pounding noises during heating cycles. See **Maintenance** (page 61) for sediment and lime scale removal procedures.
- Normal operating noise of electrical components; Combustion Blower, transformer hum, relay contact closure.

WATER LEAKAGE IS SUSPECTED

- Ensure the water heater drain valve is tightly closed.
- Check inlet/outlet water connections and system piping.
- Check the Temperature-Pressure Relief Valve.
- Excessive water temperature.
- Excessive water pressure.
- Defective Temperature-Pressure Relief Valve.

NOTE: Excessive water pressure is the most common cause of Temperature-Pressure Relief Valve leakage. Excessive water system pressure is most often caused by "thermal expansion" in a "closed system." See **Thermal Expansion** and **Closed Water Systems** (page 15). The Temperature-Pressure Relief Valve is not intended for the constant relief of thermal expansion.

Temperature-Pressure Relief Valve leakage due to pressure build up in a closed system that does not have a thermal expansion tank installed is not covered under the limited warranty. See the Commercial Integrated Tankless on Tank Limited Warranty provided with this water heater.

Thermal expansion tanks must be installed on all closed water systems.

REPLACEMENT PARTS

Replacement parts may be ordered from the manufacturer, authorized service agencies or distributors. When ordering parts be sure to have the complete water heater Model Number, Serial Number and Series Number available. This information can be found on the rating label affixed to the water heater.

Refer to the parts list included with the water heater from the factory for more information or call the parts department or technical support phone number listed on the back cover of this manual for further assistance.

GENERAL FAULT AND ALERT CONDITIONS

FAULT CONDITIONS

When the control system declares a fault condition it will display an error code on the control system's LCD. The control system will lock out and disable heating operation until the condition is corrected. The water heater must be serviced by a qualified service agent before operation can be restored.

DIAGNOSTIC CHECKS

⚠ WARNING	
	Electrical Shock Hazard
	<ul style="list-style-type: none">• Turn off power at the branch circuit breaker serving the water heater before performing any service.• Label all wires prior to disconnecting when performing service. Wiring errors can cause improper and dangerous operation.• Verify proper operation after servicing.• Failure to follow these instructions can result in personal injury or death.



The following section, **Water Heating Unit Controller Fault and Alert Conditions** (page 59), lists some of the error codes the control system will display on the LCD when there are operational problems. This is not a complete list. Along with each of the error codes described, there will be a list of possible causes and things to check and repair.

Only qualified service agents, as defined in **Qualifications** (page 6), using appropriate test equipment, should perform any service procedures on the water heater.

NOTE: If you are not qualified and licensed or certified as required by the authority having jurisdiction to perform a given task do not attempt to perform any of the diagnostic or service procedures described in the following section.

If you do not understand the instructions in the following section do not attempt to perform any procedures.

Call the technical support phone number listed on the back cover of this manual for further technical assistance or to locate a qualified service agent in your area.

⚠ WARNING	
Jumping out control circuits or components can result in property damage, personal injury or death.	
<ul style="list-style-type: none">• Service should only be performed by a qualified service technician using proper test equipment.• Altering the water heater controls and/or wiring in any way could result in permanent damage to the controls or water heater and is not covered under the limited warranty.	
	<p>Any bypass or alteration of the water heater controls and/or wiring will result in voiding the appliance warranty.</p>
	

TROUBLESHOOTING CHART

	Problem	Solutions
Temperature and Amount of Hot Water	It takes a long time to get hot water at the fixtures.	<ul style="list-style-type: none"> The time it takes to deliver hot water from the water heater to your fixtures depends on the length of piping between the two. The longer the distance or the bigger the pipes, the longer it will take to get hot water. If you would like to receive hot water to your fixtures more quickly you may want to consider a hot water recirculation system. See Circulation Pumps (page 12).
	The water is not hot enough.	<ul style="list-style-type: none"> Check cross plumbing between the cold water lines and hot water lines. Is the gas supply valve open fully? See Initial Operation (page 49). Is the gas line sized properly? See Gas Line Sizing (page 39). Is the gas supply pressure sufficient? See Measuring Inlet Gas Pressure (page 42) and Supply Gas Pressure Adjustment (page 42). Is the set temperature set too low? See Setting the Outlet Water Temperature (page 52) and Default Outlet Temperature (page 53).
	The water is too hot.	<ul style="list-style-type: none"> Is the set temperature set too high? See Setting the Outlet Water Temperature (page 52) and Default Outlet Temperature (page 53).
	The hot water is not available when a fixture is opened.	<ul style="list-style-type: none"> Make sure the unit has 120 VAC, 60 Hz power supply. If you are using the remote controller and/or temperature controller, is the power button turned on? Is the gas supply valve open fully? See Initial Operation (page 49). Is the water supply valve open fully? See Initial Operation (page 49). Is the filter on the cold water inlet clean? See Draining the Water Heating Unit (page 62). Is the hot water fixture sufficiently open to draw at least 0.5 GPM (1.9 L/min) through the water heater? See Flow Rates (page 49). Is the unit frozen? See Freeze Protection System (page 53). Is there enough gas in the tank / cylinder? (For Propane models)
	The hot water turns cold and stays cold.	<ul style="list-style-type: none"> Is the flow rate enough to keep the water heater running? See Flow Rates (page 49). If there is a recirculation system installed, does the recirculation line have enough check valves? See Water Piping Diagrams (page 66). Is the gas supply valve open fully? See Initial Operation (page 49) Is the filter on the cold water inlet clean? See Draining the Water Heating Unit (page 62). Are the fixtures clean of debris and obstructions? Check if the flow rate is too low. See Flow Rates (page 49).
	Fluctuation in hot water temperature.	<ul style="list-style-type: none"> Is the filter on the cold water inlet clean? See Draining the Water Heating Unit (page 62). Is the gas line sized properly? See Gas Line Sizing (page 39). Is the supply gas pressure sufficient? See Measuring Inlet Gas Pressure (page 42) and Supply Gas Pressure Adjustment (page 42). Check for cross connection between the cold water lines and hot water lines.
Water Heater	Unit does not ignite when water goes through the unit.	<ul style="list-style-type: none"> Is the flow rate over 0.5 GPM (1.9 L/min)? See Flow Rates (page 49). Check for the filter on the cold water inlet. See Draining the Water Heating Unit (page 62). Check for reverse connection and cross connection. If you use the remote controller and/or temperature controller, is the power button turned on? Check if the inlet temperature is too high. If it is too close to the set temperature, the water heater will not activate.
	The fan motor is still spinning after operation has stopped.	<ul style="list-style-type: none"> This is normal. After operation has stopped, the fan motor keeps running from 15 to 70 seconds in order to re-ignite quickly, as well as purge all the exhaust gas out of the flue.
	Unit sounds abnormal while in operation	Contact the manufacturer at 1-877-737-2840 (USA) 1-888-479-8324 (Canada).

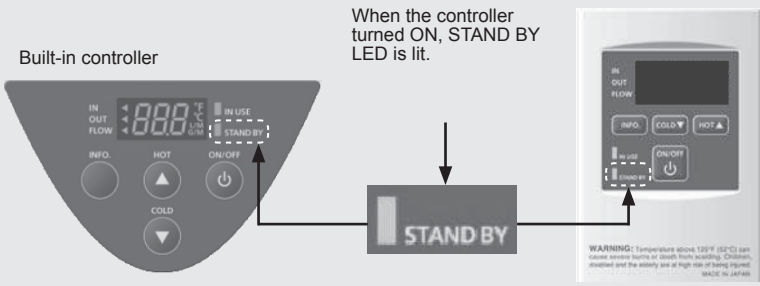
	Problem	Solutions
Built-in Controller	Controller does not display anything when the power button is turned on.	<ul style="list-style-type: none"> • Make sure the unit is supplied with power. • Make sure the connection to the unit is correct. See Electrical Connections (page 43). <p>NOTICE:</p> <p>When the unit has not operated for five minutes or more, the display of the controllers turns off to conserve energy.</p> 
	An ERROR code is displayed. r	Please see Error Codes (page 58).

ERROR CODES

The units have self-diagnostic functions for safety and convenience when troubleshooting.

If there is a problem with the installation or the unit, the error code will be displayed on the built-in controller and remote controller.

Consult the table on the following pages for the description of each error code.



Figure 56. Error Codes on On-Board Panel



Figure 57. Error Codes on Remote Control

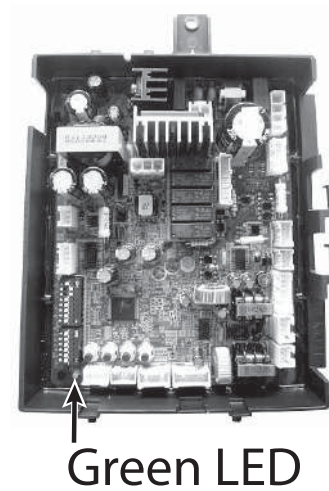

Figure 58. Error Codes on Computer Board

Example: Single Unit Installation

Error Condition: Thermistor Failure

Remote Controller or On-board Control Panel LCD screen:



Computer Board:

The green LED on the computer board will indicate this code with two flashes every 1/2 second. The pattern will repeat with a three second delay between patterns.

WATER HEATING UNIT CONTROLLER FAULT AND ALERT CONDITIONS

If the error code is displayed on the computer board of the water heater or remote controller and/or temperature controller, please check the following. After checking, consult with the manufacturer.

Table 23. Control Board Green LED Flash Codes

Controller	Green LED	Malfunction Description	Diagnosis
031	One Flash	Incorrect DIP switch setting	<ul style="list-style-type: none"> Check the DIP switch settings on the control board (Part #701).
101	Five Flashes	Warning for the "991" error code	<ul style="list-style-type: none"> Check the gas type of the water heater. Check if there is any blockage in the intake air and/or exhaust. If the water heater is installed as a direct-vent system, check whether there is enough distance between the intake air terminal and the exhaust terminal. Check the altitude/elevation of area of where the water heater is installed. Check if there is grease and/or dirt in the burner (Part #101) and the fan motor (Part #103), especially if the water heater has been installed in a contaminated area.
111	Three Flashes	Ignition failure	<ul style="list-style-type: none"> Check if the Hi-limit switch (Part #412) is properly functioning. Check for connection/breakage of wires (Part #413, 708, 709, 711) burn marks on the computer board (Part #701), and/or soot on the flame rod (Part #108). Check if there is a buzzing spark ignition sound coming from the burner (Part #101) when water heater prepares for combustion. Listen for the double "clunk" sound coming from gas valve assembly (Part #102) when water heater goes into combustion. Check if there is leaking from heat exchanger (Part #401).
121	Three Flashes	Loss of flame	<ul style="list-style-type: none"> Check if the Hi-limit switch (Part #412) is functioning properly. Check for connection/breakage of wires (Part #413, 708, 709, 711) burn marks on the computer board (Part #701), and/or soot on the flame rod (Part #108). Check if there is leaking from heat exchanger (Part #401).
311	Two Flashes	Heat exchanger thermistor failure	<ul style="list-style-type: none"> Check for connection/breakage of wires and/or debris on thermistor (Part #407, 408, 411, 715).
321	Two Flashes	Inlet thermistor failure	
331	Two Flashes	Outlet thermistor failure	
341	Two Flashes	Exhaust thermistor failure	
391	Two Flashes	Air-fuel ratio rod failure	<ul style="list-style-type: none"> Check for connection/breakage of wires (Part #709) and/or soot on the AFR rod (Part #108).
441	Two Flashes	Flow sensor failure	<ul style="list-style-type: none"> Check for connection/breakage of wires and/or debris on the flow sensor impeller (Part #402).
510	Six Flashes	Abnormal main gas solenoid valve	<ul style="list-style-type: none"> Check for connection/breakage of wires (Part #708) and/or burn marks on the computer board (Part #701).
551	Six Flashes	Abnormal gas solenoid valve	<ul style="list-style-type: none"> Check for connection/breakage of wires (Part #708) and/or burn marks on the computer board (Part #701).
611	Four Flashes	Fan motor fault	<ul style="list-style-type: none"> Check for connection/breakage of wires, dust buildup in the fan motor (Part #103) and/or burn marks on the computer board (Part #701). Check for frozen/corrosion of connectors (Part #103).
651	Four Flashes	Flow adjustment valve fault	<ul style="list-style-type: none"> Inspect the flow adjustment valve (Part #402), for connection/breakage of wires, locked motor drive due to scale buildup, and/or water leakage.

Table 23. Control Board Green LED Flash Codes

Controller	Green LED	Malfunction Description	Diagnosis
661	Four Flashes	Bypass valve fault	<ul style="list-style-type: none"> Inspect the bypass valve (Part #403), for connection/breakage of wires, locked motor drive due to scale buildup, and/or water leakage.
701	One Flash	Computer board fault	<ul style="list-style-type: none"> Check for connection/breakage of wires (Part #714).
711	One Flash	Gas solenoid valve drive circuit failure	<ul style="list-style-type: none"> Refer to the 111 and 121 error codes.
721	Six Flashes	False flame detection	<ul style="list-style-type: none"> Check if condensate drain is installed on the vent collar of the water heater. Check if there is leaking from heat exchanger (Part #401).
741	N/A	Miscommunication between water heater and remote controller	<ul style="list-style-type: none"> Check the model type of the remote controller. Inspect the connections between the water heater and remote controller. Check the power supply of the water heater.
751	N/A	Miscommunication between water heater and temperature controller	<ul style="list-style-type: none"> Inspect the connections between the water heater and temperature controller. Check the power supply of the water heater.
941	Five Flashes	Abnormal exhaust temperature	<ul style="list-style-type: none"> Check if the set temperature is higher than 140°F (60°C) and the system is Recirculation.
991	Five Flashes	Imperfect combustion	<ul style="list-style-type: none"> Check the gas type of the water heater. Inspect the environment around the water heater. Determine how long the unit has been installed. Check the altitude/elevation of the area of where the water heater is installed. Check if there is any blockage in the intake air and/or exhaust. If the water heater is installed as a direct-vent system, check whether there is enough distance between the intake air terminal and the exhaust terminal. Check if there is grease and/or dirt in the burner (Part #101) and the fan motor (Part #103), especially if the water heater has been installed in a contaminated area.

MAINTENANCE

GENERAL

Keep water heater area clear and free from combustible materials, gasoline, and other flammable vapors and liquids. See **Locating the Water Heater** (page 11).

Water heater maintenance includes periodic tank flushing and cleaning, and removal of lime scale. The water heater should be inspected and adjusted to maintain proper combustion. See **Initial Operation** (page 49). A periodic inspection of the venting system should be made, see **Table 24** (page 61). Where used, water circulating pump(s) should be oiled according to the pump manufacturers recommendations.

PRECAUTIONS

⚠ CAUTION

Do not operate the water heater if it has been exposed to or exhibits the following:

- Exposed to flooding or water damage
- External damage.
- Firing without water.
- Sooting.

Do not operate the water heater until all corrective steps have been made by a qualified service technician.

Never operate the water heater without first being certain it is filled with water and a properly sized and rated Temperature-Pressure Relief Valve is installed in the relief valve opening on the water heater. See **Water Line Connections** (page 44).



⚠ WARNING

Explosion Hazard

- Overheated water can cause water tank explosion.
- Properly sized temperature and pressure relief valve must be installed in the opening provided.

If overheating occurs or the gas supply fails to shut off, turn off the Main Gas Shutoff valve. See **Figure 44** (page 39).

Table 24. Maintenance Schedule

Component	Operation	Interval	Required
Cold water inlet filter	Inspection/Cleaning	Annually	See Draining the Water Heating Unit .
Burner	Inspection/Cleaning	Annually	<ul style="list-style-type: none"> • Check for dust, lint, grease or dirt. • Check the burner flames (Figure 59)
Pressure Only Relief Valve	Test Operation	Semi Annually	Test
T&P Valve	Test Operation	Semi Annually	Test
Vent System	Inspection	Annually	<ul style="list-style-type: none"> • Check for any leaks, corrosion, blockages or damage. • Reseal/Repair

WATER HEATING UNIT MAINTENANCE AND SERVICE



⚠ WARNING

Shock or Electrocutation Hazard

- Turn off the electrical power supply and close the manual gas shutoff valve and the manual water control valve before servicing.
- Failure to do so could result in severe personal injury, or death.

- Clean the cold-water inlet filter. (Refer to **Draining the Water Heating Unit** (page 62).
- Be sure that all openings for combustion and ventilation air are not blocked.
- The venting system should be checked annually for any leaks, corrosion, blockages or damage.
- The burner should be checked annually for dust, lint, grease or dirt.
- Keep the area around the water heater clear. Remove any combustible materials, gasoline or any flammable vapors and liquids.
- If the relief valve discharges periodically, it may be due to thermal expansion in a closed water supply system. Contact the water supplier or local plumbing inspector on how to correct this situation.
- Visually check the burner flames (see below) through the burner window in the burner assembly located at the middle of the water heater.

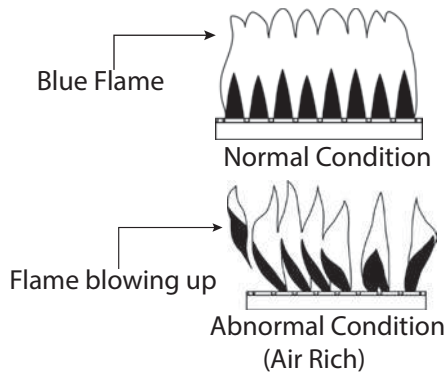

Figure 59. Burner Flame Visual Check

The manufacturer recommends having the unit checked once a year or as necessary by a licensed technician. If repairs are needed, any repairs should be done by a licensed technician.

DRAINING THE WATER HEATING UNIT

1. Close the manual gas shutoff valve.
2. Turn off power to the unit and wait a couple of seconds. Turn on again.
3. Wait 30 seconds, and then turn off power to the unit.
4. Close the inlet water valve.

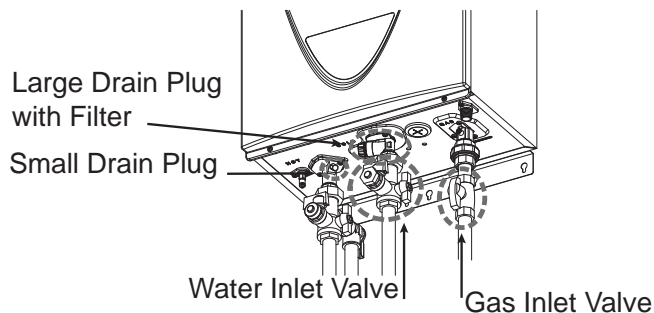
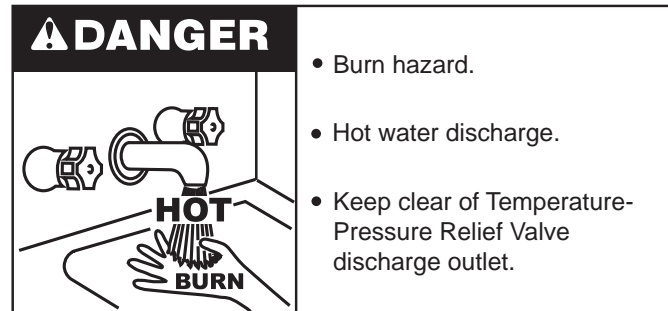

Figure 60. Drain Plugs

5. Open all hot water taps in the house. When the residual water flow has ceased, close all hot water taps.
6. Have a bucket or pan to catch the water from the unit's drain plugs. If isolation valves are installed, open the drains to drain the water. If isolation valves are not installed, unscrew the two drain plugs (large and small) to drain all the water out of the unit. Do not lose the o-rings that will be on the two drain plugs.
7. Wait a few minutes to ensure all water has completely drained from the unit.
8. **Clean the filter:** Check the water filter located within the cold inlet. With a tiny brush, clean the water filter of any debris which may have accumulated and reinsert the filter back into the cold water inlet.
9. Securely screw the drain plugs back into place.
10. Hand-tighten only.

DRAINING AND FLUSHING THE STORAGE TANK

It is recommended that the water heater storage tank be drained and flushed every 6 months to reduce sediment buildup. The water heater should be drained if being shut down during freezing temperatures. See **Features and Components** (page 7) for the location of the water heater components described below.



Draining the Water Heater Storage Tank

To drain the water heater storage tank, do the following:

1. Turn off the electrical supply to the water heater.
2. Turn off the gas supply at the Main Gas Shutoff Valve if the water heater is going to be shut down for an extended period.
3. Ensure the cold water inlet valve is open.
4. Open a nearby hot water faucet and let the water run until the water is no longer hot.
5. Connect a hose to the water heater drain valve and terminate it to an adequate drain.
6. Close the cold water inlet valve.
7. Open the water heater drain valve and allow all the water to drain from the storage tank.
8. Close the water heater drain valve when all water in the storage tank has drained.
9. Close the hot water faucet opened in Step 5.
10. If the water heater is going to be shut down for an extended period, the drain valve should be left open.

Flushing the Water Heater Storage Tank

1. Turn off the electrical supply to the water heater.
2. Ensure the cold water inlet valve is open.
3. Open a nearby hot water faucet and let the water run until the water is no longer hot. Then close the hot water faucet.
4. Connect a hose to the drain valve and terminate it to an adequate drain.
5. Ensure the drain hose is secured before and during the entire flushing procedure. Flushing is performed with system water pressure applied to the water heater.
6. Open the water heater drain valve to flush the storage tank.
7. Flush the water heater storage tank to remove sediment and allow the water to flow until it runs clean.
8. Close the water heater drain valve when flushing is completed.
9. Remove the drain hose.

10. Fill the water heater - see **Filling The Water Heater Storage Tank** (page 49).
11. Turn on the electrical supply to place the water heater back in operation.
12. Allow the water heater to complete several heating cycles to ensure it is operating properly.

DRAIN VALVE

The water heaters covered in this manual are equipped with a drain valve, see **Features and Components** (page 7) for location.

RELIEF VALVE TESTS

Water heaters covered by this manual have two pressure relief valves that should be tested periodically: the Temperature-Pressure relief valve and the Pressure-Only relief valve.

Test each of these valves every six months to ensure that they are in operating condition.

When checking the valves' operation, make sure that (1) no one is in front of or around the outlet of the discharge line of the valve being tested, and (2) that the water discharge will not cause any property damage, as the water may be extremely hot. Use care when operating valve as the valve may be hot.

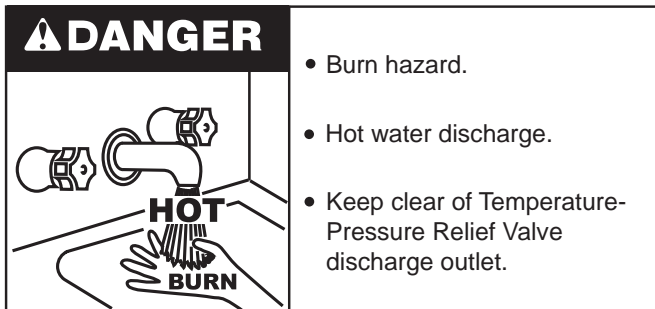

To check the relief valves, lift the lever at the end of the valve several times, see **Figure 61**. The valve should seat properly and operate freely.

If after manually operating the valve, it fails to completely reset and continues to release water, immediately close the cold water inlet to the water heater and drain the water heater, see **Water heating unit Maintenance and Service** (page 61). Replace the Temperature-Pressure Relief Valve with a properly rated/sized new one, see **Water Line Connections** (page 44) **Water Piping Diagrams** (page 66) for instructions on replacement.

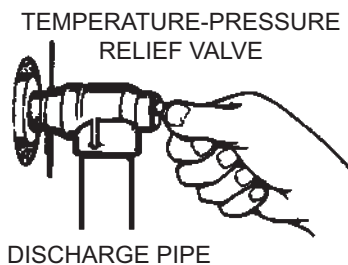

Figure 61. Operating the Relief Valve Lever

If the Temperature-Pressure Relief Valve on the water heater weeps or discharges periodically, this may be due to thermal expansion.

NOTE: Excessive water pressure is the most common cause of Temperature-Pressure Relief Valve leakage. Excessive water system pressure is most often caused by "thermal expansion" in a "closed system." See **Thermal Expansion** (page 15) and **Closed Water Systems** (page 15). The Temperature-Pressure Relief Valve is not intended for the constant relief of thermal expansion.

Temperature-Pressure Relief Valve leakage due to pressure build up in a closed system that does not have a thermal expansion tank installed is not covered under the limited warranty. See the Commercial Water Heater Limited Warranty provided with this water heater.

Thermal expansion tanks must be installed on all closed water systems.

Do not plug the Temperature-Pressure Relief Valve opening. This can cause property damage, serious injury or death.

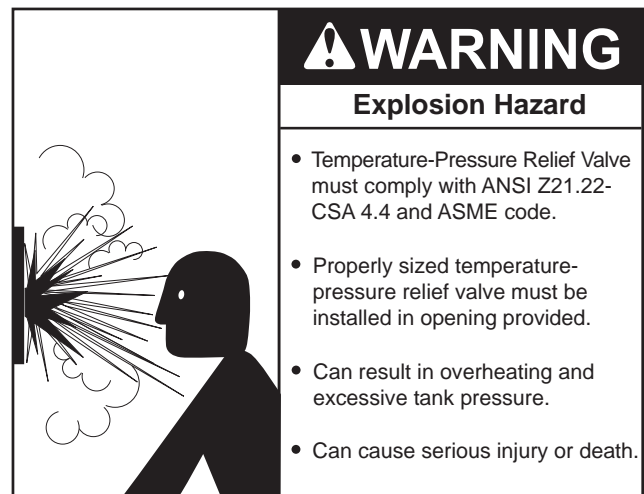

VENT SYSTEM MAINTENANCE

Examine the vent system every 6 months. Points of inspection are as follows:

1. Check for obstructions and/or deterioration of the intake air and/or vent piping and the intake air and vent terminations. Replace immediately where needed.
2. The debris screens in the intake air and vent terminations should be cleaned of foreign material and soot.

NOTE: Do not reach inside the vent termination when the heater is in operation.

3. Check all vent system connections for leakage and repair or reseal as necessary.

DIAGRAMS

WIRING DIAGRAM

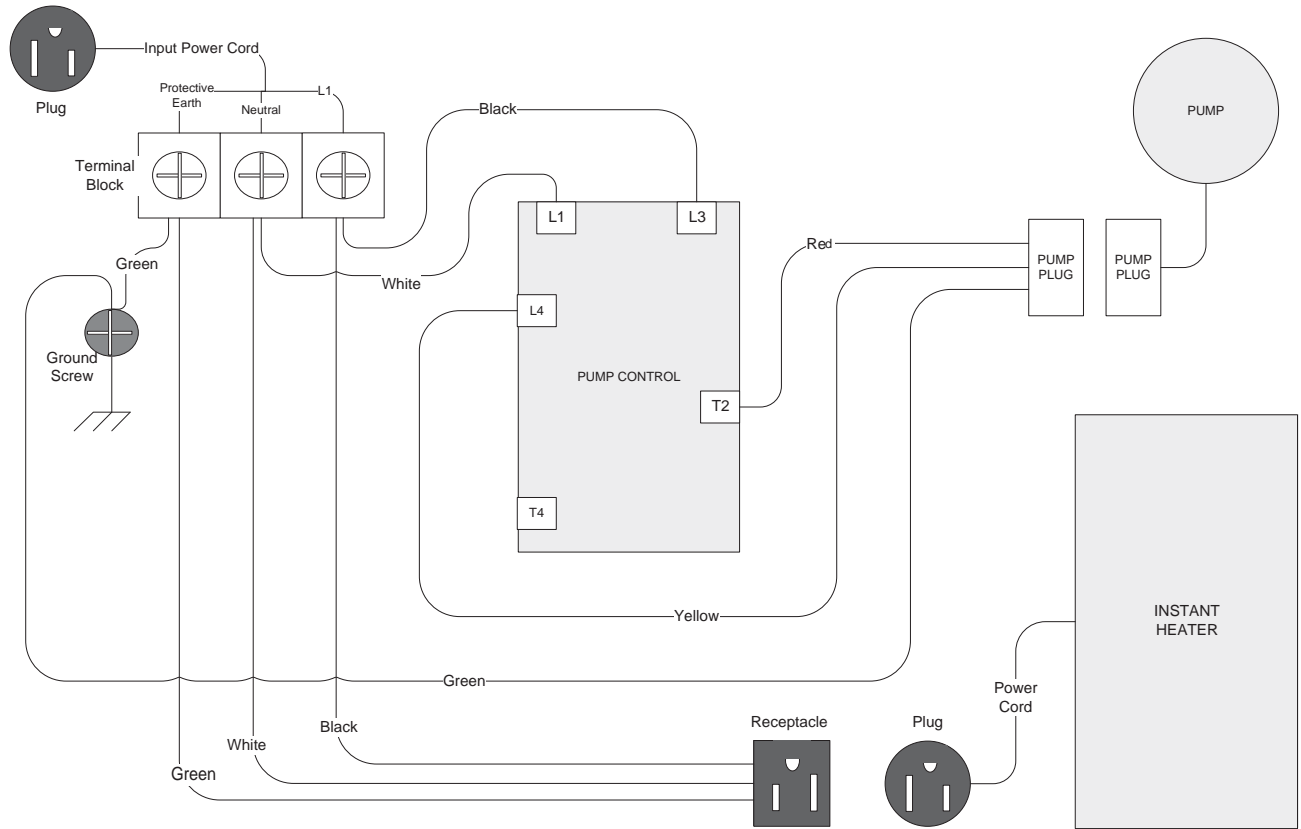

— = 18AWG AWM wire 105°C 600V UL 1015

Figure 62. Wiring Diagram

CIRCULATION PUMP WIRING DIAGRAMS

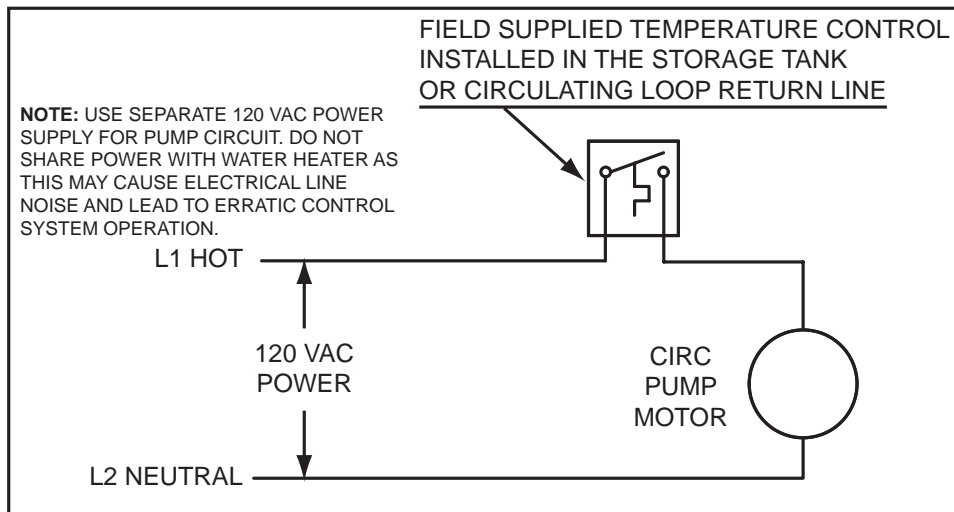

Figure 63. Circulating Pump Wiring Diagram - Storage Tank or Building Recirculation

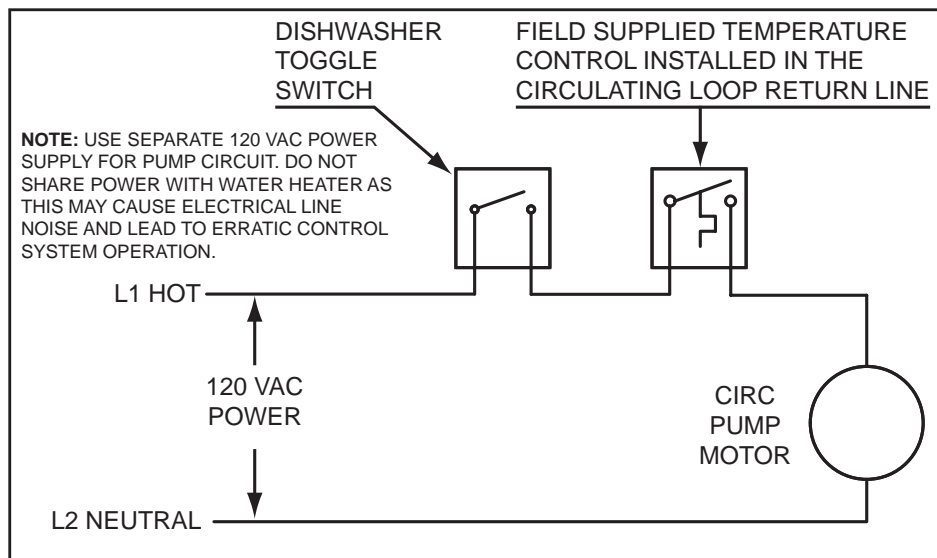

Figure 64. Circulating Pump Wiring Diagram - Dishwasher Loop Toggle Switch

WATER PIPING DIAGRAMS

Before installation of water piping review the following:

1. See **Mixing Valves** (page 14).
2. See **Dish-washing Machines** (page 15).
3. See **Thermal Expansion** and **Closed Water Systems** (page 15).
4. See **Water Line Connections** (page 44).
5. If a pump is being installed between a water heater and storage tank or on a building recirculation loop wire according to **Figure 63** (page 65).
6. If a pump is being installed in a recirculation loop between the water heater and a commercial dishwasher wire according to **Figure 63** or **Figure 64** (page 65).

ONE WATER HEATER, SINGLE TEMPERATURE WITH BUILDING RECIRCULATION

WARNING: THIS DRAWING SHOWS SUGGESTED PIPING CONFIGURATION AND OTHER DEVICES; CHECK WITH LOCAL CODES AND ORDINANCES FOR ADDITIONAL REQUIREMENTS.

ANY MATERIAL, COMPONENT OR VENDOR CHANGE MUST HAVE PRIOR APPROVAL BY THE APPLICABLE PRODUCT ENGINEERING DEPARTMENT.

LEGEND

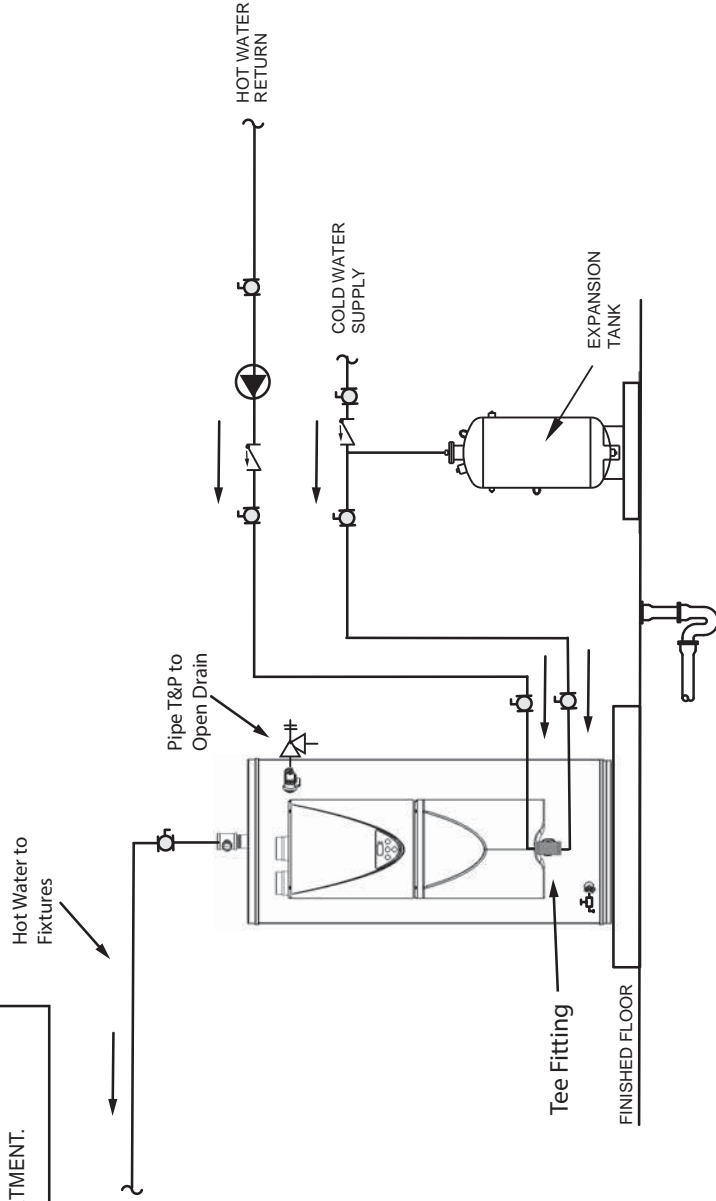

NOTES:

1. Preferred piping method.
2. The temperature and pressure relief valve setting shall not exceed pressure rating of any component in the system.
3. Service valves are shown for servicing unit. However, local codes shall govern their usage.

WATER PIPING DIAGRAMS

Before installation of water piping review the following:

1. See **Mixing Valves** (page 14)
2. See **Dish-washing Machines** (page 15).
3. See **Thermal Expansion** and **Closed Water Systems** (page 15).
4. See **Water Line Connections** (page 44).

5. If a pump is being installed between a water heater and storage tank or on a building recirculation loop wire according to **Figure 63** (page 65).
6. If a pump is being installed in a recirculation loop between the water heater and a commercial dishwasher wire according to **Figure 63** or **Figure 64** (page 65).

ONE WATER HEATER, TWO TEMPERATURE WITH HIGH TEMPERATURE LOOP RECIRCULATION WITH BUILDING RECIRCULATION

WARNING: THIS DRAWING SHOWS SUGGESTED PIPING CONFIGURATION AND OTHER DEVICES; CHECK WITH LOCAL CODES AND ORDINANCES FOR ADDITIONAL REQUIREMENTS.

ANY MATERIAL, COMPONENT OR VENDOR CHANGE MUST HAVE PRIOR APPROVAL BY THE APPLICABLE PRODUCT ENGINEERING DEPARTMENT.

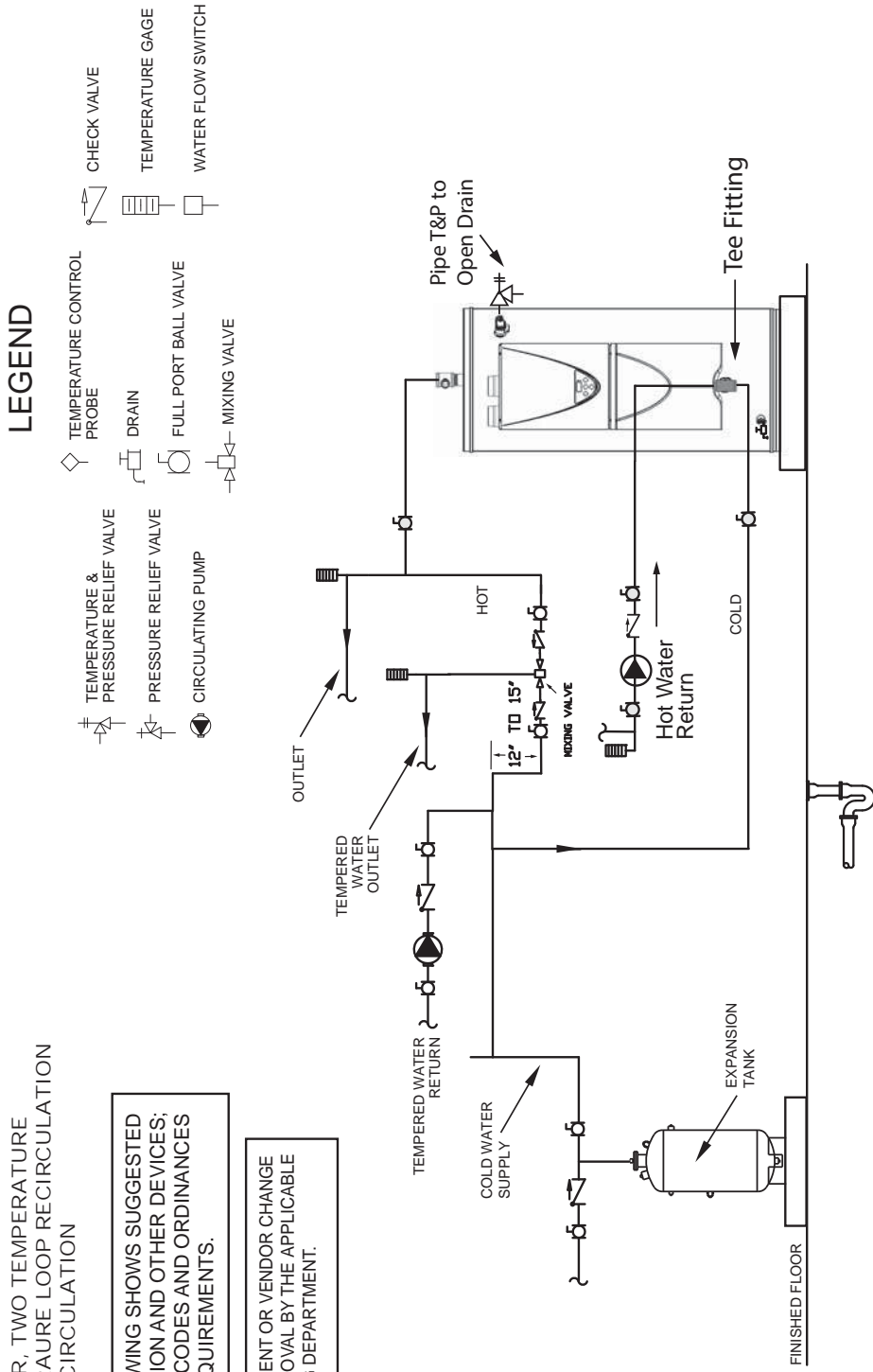

NOTES:

1. Preferred piping method.
2. The temperature and pressure relief valve setting shall not exceed pressure rating of any component in the system.
3. Service valves are shown for servicing unit. However, local codes shall govern their usage.

WATER PIPING DIAGRAMS

Before installation of water piping review the following:

1. See *Mixing Valves* (page 14).
2. See *Dish-washing Machines* (page 15).
3. See *Water Line Connections* (page 44).
4. See *Thermal Expansion* and *Closed Water Systems* (page 15).
5. If a pump is being installed between a water heater and storage tank or on a building recirculation loop wire according to **Figure 63** (page 65).
6. If a pump is being installed in a recirculation loop between the water heater and a commercial dishwasher wire according to **Figure 63** or **Figure 64** (page 65).

ONE WATER HEATER, SINGLE TEMPERATURE WITH VERTICAL STORAGE TANK FORCED RECIRCULATION

WARNING: THIS DRAWING SHOWS SUGGESTED PIPING CONFIGURATION AND OTHER DEVICES; CHECK WITH LOCAL CODES AND ORDINANCES FOR ADDITIONAL REQUIREMENTS.

ANY MATERIAL, COMPONENT OR VENDOR CHANGE MUST HAVE PRIOR APPROVAL BY THE APPLICABLE PRODUCT ENGINEERING DEPARTMENT.

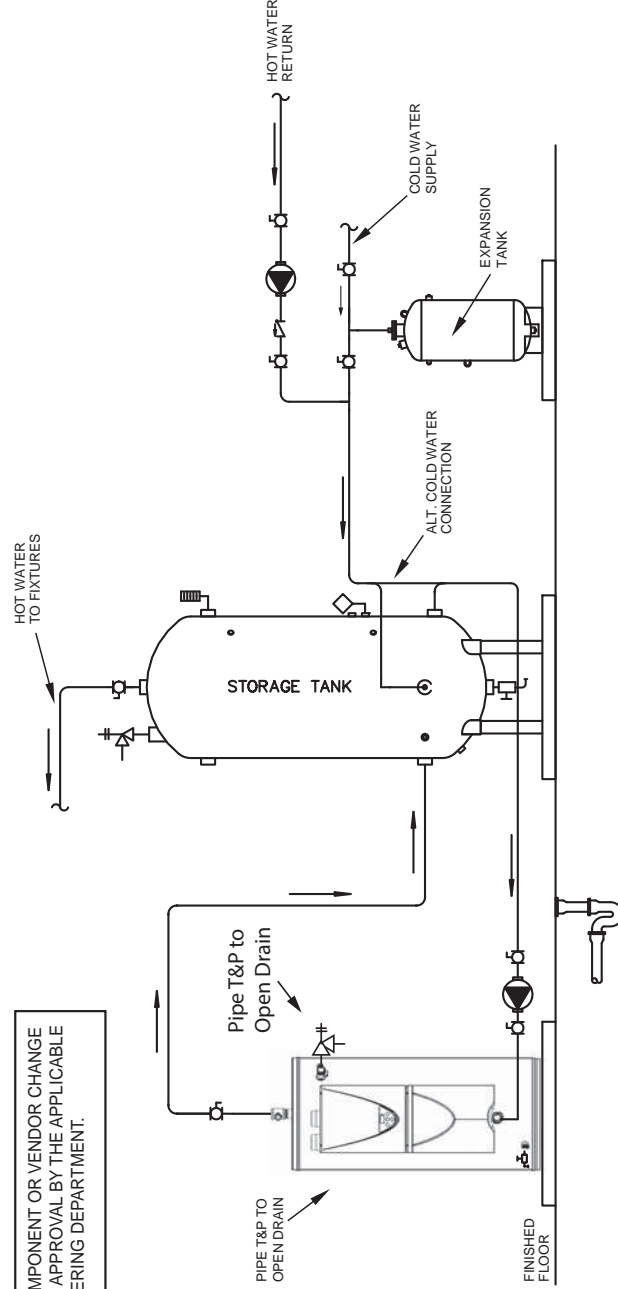

NOTES:

1. Preferred piping method.
2. The temperature and pressure relief valve setting shall not exceed pressure rating of any component in the system.
3. Service valves are shown for servicing unit. However, local codes shall govern their usage.
4. The tank temperature control should be wired to and control the pump between the water heater(s) and the storage tank(s).
5. The water heater's operating thermostat should be set 5 degrees F higher than the tank temperature control.

WATER PIPING DIAGRAMS

Before installation of water piping review the following:

1. See *Mixing Valves* (page 14).
2. See *Dish-washing Machines* (page 15).
3. See *Water Line Connections* (page 44).
4. See *Thermal Expansion and Closed Water Systems* (page 15).
5. If a pump is being installed between a water heater and storage tank or on a building recirculation loop wire according to **Figure 63** (page 65).
6. If a pump is being installed in a recirculation loop between the water heater and a commercial dishwasher wire according to **Figure 63** or **Figure 64** (page 65).

ONE WATER HEATER, SINGLE TEMPERATURE WITH HORIZONTAL STORAGE TANK FORCED RECIRCULATION WITH BUILDING RECIRCULATION

WARNING: THIS DRAWING SHOWS SUGGESTED PIPING CONFIGURATION AND OTHER DEVICES; CHECK WITH LOCAL CODES AND ORDINANCES FOR ADDITIONAL REQUIREMENTS.

ANY MATERIAL, COMPONENT OR VENDOR CHANGE MUST HAVE PRIOR APPROVAL BY THE APPLICABLE PRODUCT ENGINEERING DEPARTMENT.

LEGEND

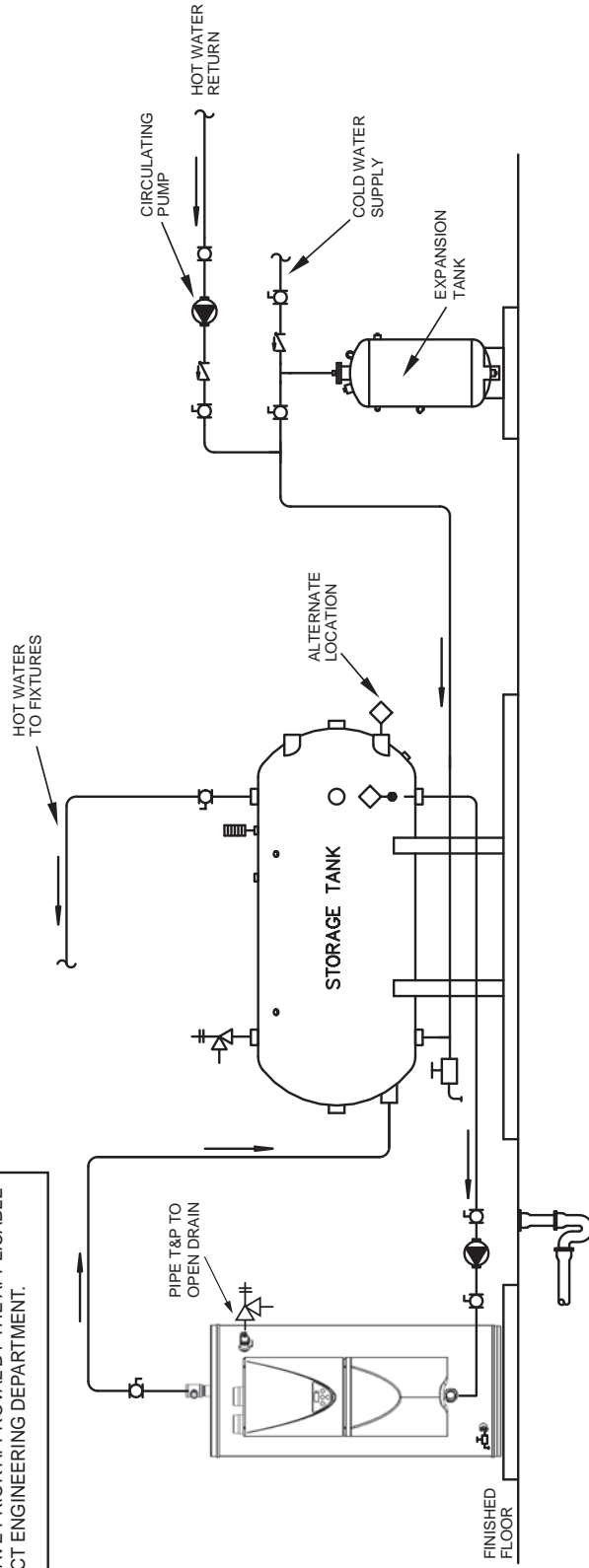

NOTES:

1. Preferred piping method.
2. The temperature and pressure relief valve setting shall not exceed pressure rating of any component in the system.
3. Service valves are shown for servicing unit. However, local codes shall govern their usage.
4. The tank temperature control should be wired to and control the pump between the water heater(s) and the storage tank(s).
5. The water heater's operating thermostat should be set 5 degrees F higher than the tank temperature control.

WATER PIPING DIAGRAMS

Before installation of water piping review the following:

1. See *Mixing Valves* (page 14).
2. See *Dish-washing Machines* (page 15).
3. See *Water Line Connections* (page 44).
4. See *Thermal Expansion* and *Closed Water Systems* (page 15).
5. If a pump is being installed between a water heater and storage tank or on a building recirculation loop wire according to **Figure 63** (page 65).
6. If a pump is being installed in a recirculation loop between the water heater and a commercial dishwasher wire according to **Figure 63** or **Figure 64** (page 65).

TWO WATER HEATERS, SINGLE TEMPERATURE WITH BUILDING RECIRCULATION

WARNING: THIS DRAWING SHOWS SUGGESTED PIPING CONFIGURATION AND OTHER DEVICES; CHECK WITH LOCAL CODES AND ORDINANCES FOR ADDITIONAL REQUIREMENTS.

ANY MATERIAL, COMPONENT OR VENDOR CHANGE MUST HAVE PRIOR APPROVAL BY THE APPLICABLE PRODUCT ENGINEERING DEPARTMENT.

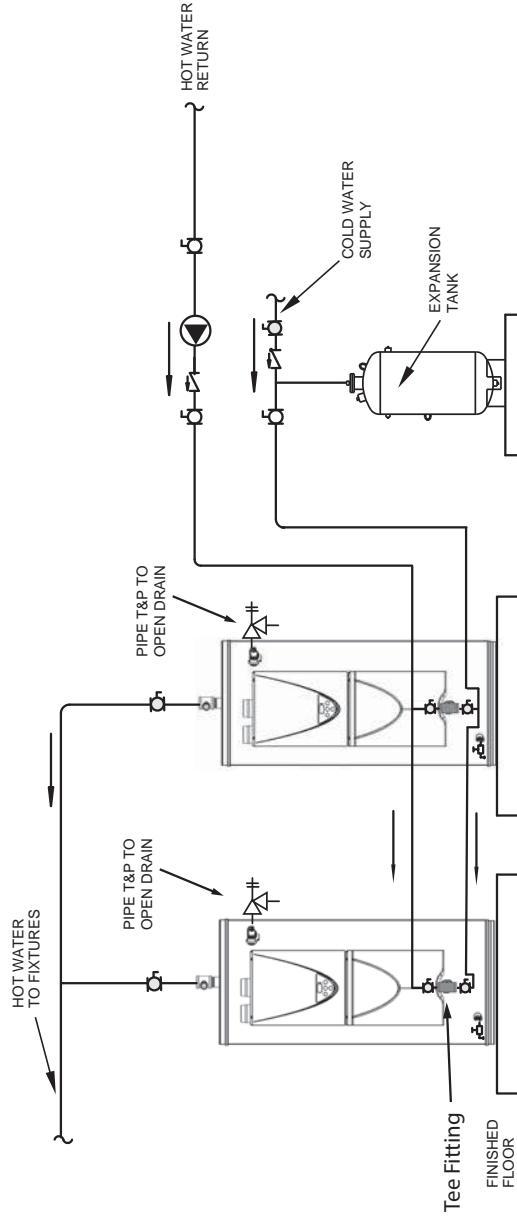

NOTES:

1. Preferred piping method.
2. The temperature and pressure relief valve setting shall not exceed pressure rating of any component in the system.
3. Service valves are shown for servicing unit. However, local codes shall govern their usage.

WATER PIPING DIAGRAMS

Before installation of water piping review the following:

1. See *Mixing Valves* (page 14).
2. See *Dish-washing Machines* (page 15).
3. See *Water Line Connections* (page 44).
4. See *Thermal Expansion* and *Closed Water Systems* (page 15).
5. If a pump is being installed between a water heater and storage tank or on a building recirculation loop wire according to **Figure 63** (page 65).
6. If a pump is being installed in a recirculation loop between the water heater and a commercial dishwasher wire according to **Figure 63** or **Figure 64** (page 65).

THREE WATER HEATERS, SINGLE TEMPERATURE WITH BUILDING RECIRCULATION

WARNING: THIS DRAWING SHOWS SUGGESTED PIPING CONFIGURATION AND OTHER DEVICES; CHECK WITH LOCAL CODES AND ORDINANCES FOR ADDITIONAL REQUIREMENTS.

ANY MATERIAL, COMPONENT OR VENDOR CHANGE MUST HAVE PRIOR APPROVAL BY THE APPLICABLE PRODUCT ENGINEERING DEPARTMENT.

LEGEND

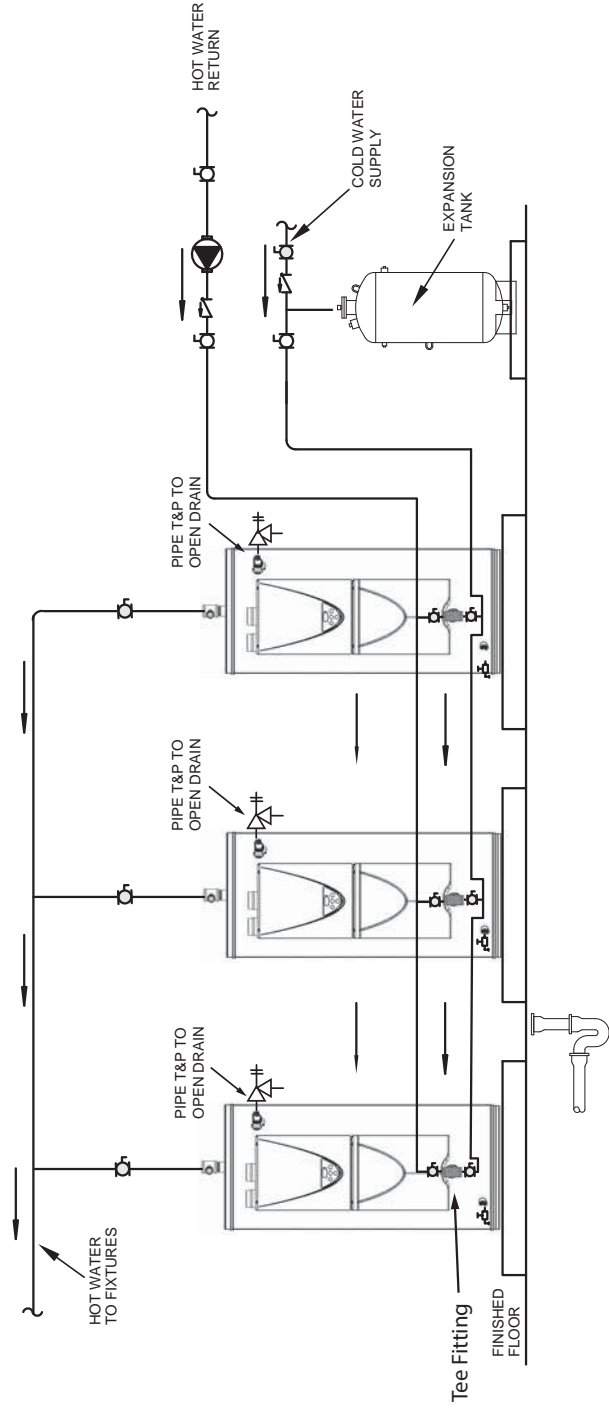
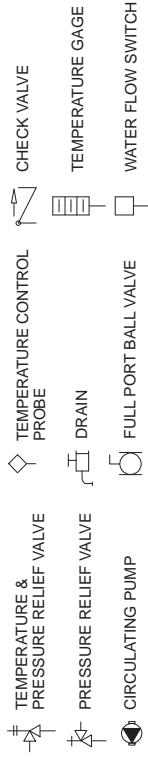

NOTES:

1. Preferred piping method.
2. The temperature and pressure relief valve setting shall not exceed pressure rating of any component in the system.
3. Service valves are shown for servicing unit. However, local codes shall govern their usage.

WATER PIPING DIAGRAMS

Before installation of water piping review the following:

1. See *Mixing Valves* (page 14).
2. See *Dish-washing Machines* (page 15).
3. See *Water Line Connections* (page 44).
4. See *Thermal Expansion* and *Closed Water Systems* (page 15).
5. See *Water Line Connections* (page 44).
6. If a pump is being installed between a water heater and storage tank or on a building recirculation loop wire according to **Figure 63** (page 65).
7. If a pump is being installed in a recirculation loop between the water heater and a commercial dishwasher wire according to **Figure 63** or **Figure 64** (page 65).

FOUR WATER HEATERS, SINGLE TEMPERATURE WITH BUILDING RECIRCULATION

WARNING: THIS DRAWING SHOWS SUGGESTED PIPING CONFIGURATION AND OTHER DEVICES; CHECK WITH LOCAL CODES AND ORDINANCES FOR ADDITIONAL REQUIREMENTS.

ANY MATERIAL, COMPONENT OR VENDOR CHANGE MUST HAVE PRIOR APPROVAL BY THE APPLICABLE PRODUCT ENGINEERING DEPARTMENT.

LEGEND

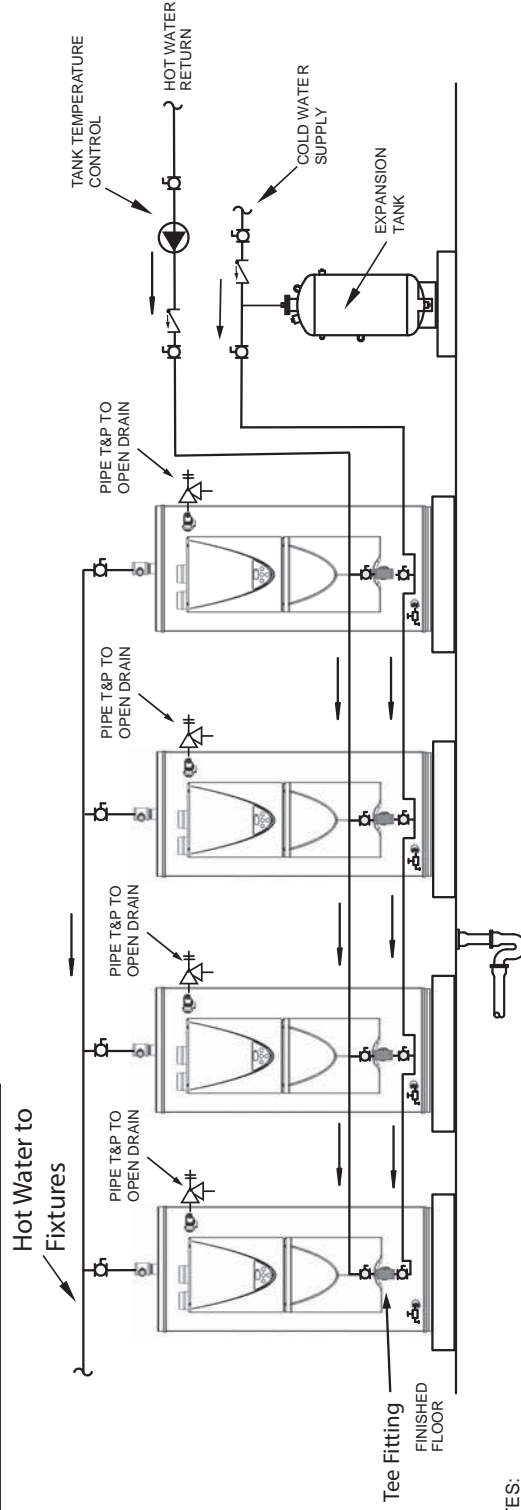
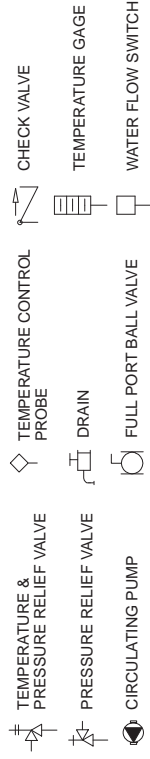

NOTES:

1. Preferred piping method.
2. The temperature and pressure relief valve setting shall not exceed pressure rating of any component in the system.
3. Service valves are shown for servicing unit. However, local codes shall govern their usage.

NOTES

NOTES

For additional information contact:
1-800-527-1953
www.hotwater.com